

1. ALL RESISTANCE VALUES ARE IN OHMS, 0.1 WATT +/- 5%.
2. ALL CAPACITANCE VALUES ARE IN MICROFARADS.
3. ALL CRYSTALS & OSCILLATOR VALUES ARE IN HERTZ.

REV	ZONE	ECN	DESCRIPTION OF CHANGE	CK APPD DATE	ENG APPD DATE
01		398634	ENGINEERING RELEASED	09/07/05	

SCHEM, SIDEBURN, M1

08/27/05

PART NUMBER	ALTERNATE FOR PART NUMBER	BOM OPTION	REF DES	COMMENTS:
385-0044	385-0053		PD1	ALT FOR BS520E0F

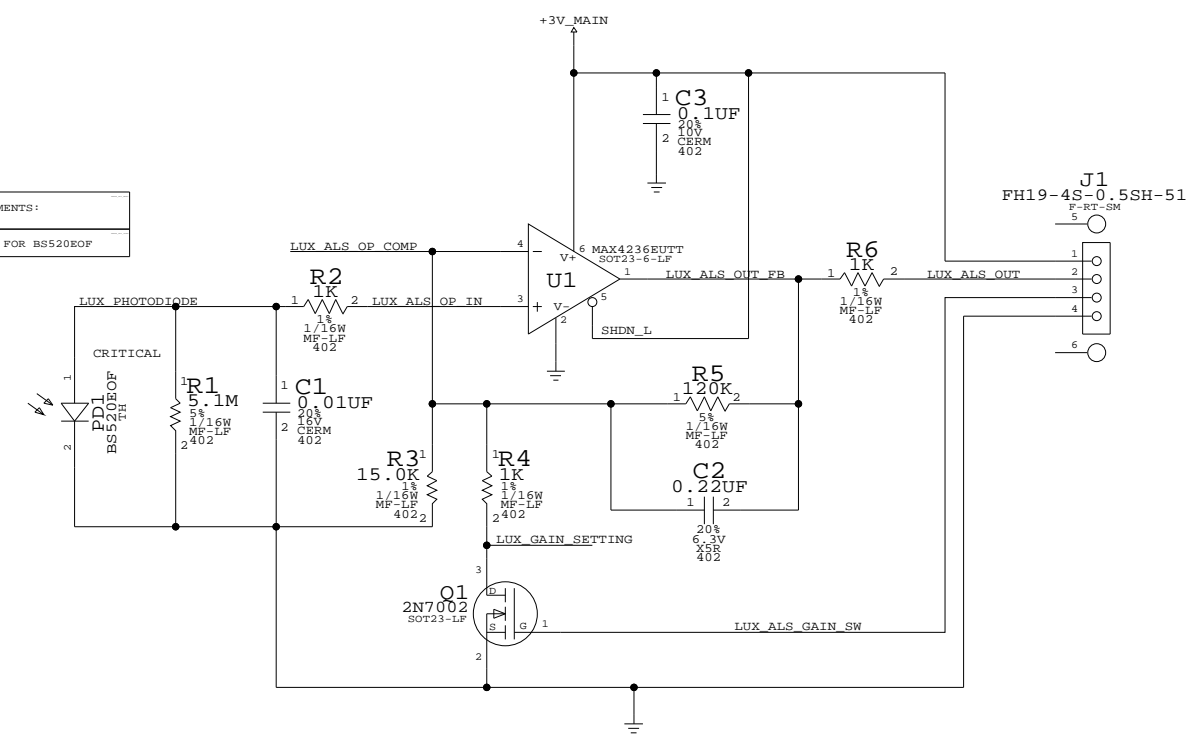

THROUGH-HOLE PINS MUST BE PLACED IN THE FOLLOWING ORDER:
POWER IS PLACED CLOSEST TO PHOTODIODE

- 1) POWER
- 2) GAIN_SW
- 3) ALS_OUT
- 4) GROUND

REVISION HISTORY

- 08/24/2005 - REV 00
INITIAL RELEASE
- 08/27/2005 - REV 01
- 1. CHANGE ZH1,2,3 AND ZH4 TO APN#518S0321 FOR FFC
- 2. VERSION CHANGE FROM 00 TO 01
- 3. THE LOCATION OF 4PIN CONNECTOR IS REVISED TO J1

PART#	QTY	DESCRIPTION	REFERENCE DESIGNATOR(S)	BOM OPTION
051-6990	1	SCHEM,ALS,LT,M1	SCH1	
820-1932	1	PCBF,ALS,LT,M1	PCB1	

DIMENSIONS ARE IN MILLIMETERS		METRIC		Apple Computer Inc.	
XX :	_____	DRAPTR	DESIGN CK	NOTICE OF PROPRIETARY PROPERTY THE INFORMATION CONTAINED HEREIN IS THE PROPRIETARY PROPERTY OF APPLE COMPUTER, INC. THE POSSESSOR AGREES TO THE FOLLOWING: I TO MAINTAIN THE DOCUMENT IN CONFIDENCE II NOT TO REPRODUCE OR COPY IT III NOT TO REVEAL OR PUBLISH IN WHOLE OR PART	
X.XX :	_____	ENG APPD	MFG APPD		
X.XXX :	_____	QA APPD	DESIGNER		
ANGLES :	_____	RELEASE	SCALE		
DO NOT SCALE DRAWING		NONE		TITLE	
 THIRD ANGLE PROJECTION		MATERIAL/FINISH NOTED AS APPLICABLE		SIZE D	DRAWING NUMBER
					051-6990
					REV. 01
				SHT 1 OF 1	