



CYPRESS

ADVANCE  
INFORMATION

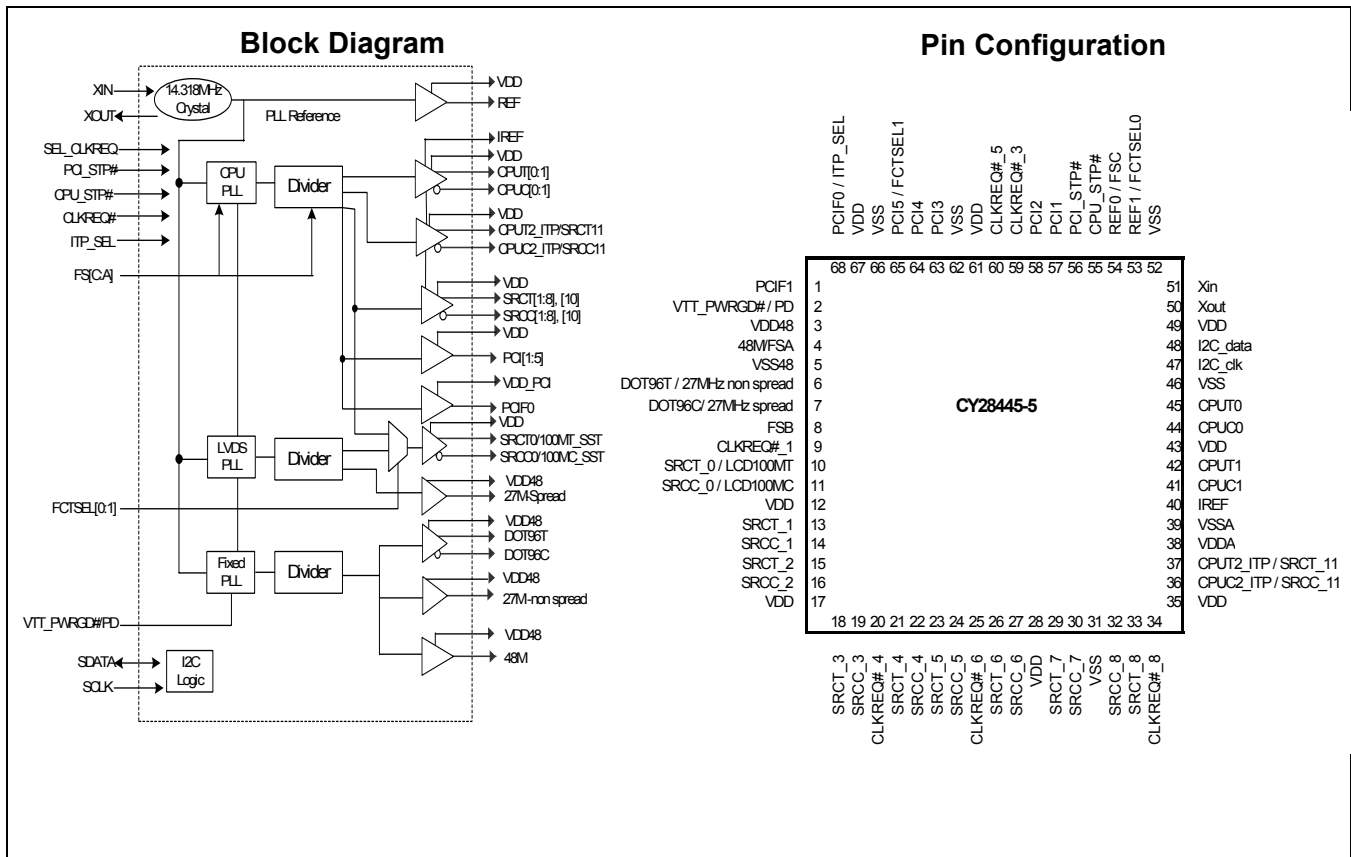
CY28445-5

# Clock Generator for Intel® Calistoga Chipset

## Features

- Compliant to Intel® CK410M
- Selectable CPU frequencies
- Differential CPU clock pairs
- 100-MHz differential SRC clocks
- 96-MHz differential dot clock
- 27MHz Spread and Non-spread video clock
- 48-MHz USB clocks
- SRC clocks independently stoppable through CLKREQ#
- 96-/100-MHz Spreadable differential video clock.
- 33-MHz PCI clock
- Buffered Reference Clock 14.318Mhz
- Low-voltage frequency select input
- I<sup>2</sup>C support with readback capabilities
- Ideal Lexmark Spread Spectrum profile for maximum electromagnetic interference (EMI) reduction
- 3.3V power supply
- 68-pin MLF package

CPU	SRC	PCI	REF	DOT96	USB_48M	LCD100M	27M
x2 / x3	x8/9/10	x6	x2	x 1	x 1	x1	x2



**Pin Descriptions**

Pin No.	Name	Type	Description																														
3, 12, 17, 28, 35, 43, 49, 60, 67	VDD	PWR	<b>3.3V power supply.</b>																														
5, 31, 46, 52, 62, 66	VSS	GND	<b>Ground.</b>																														
57, 58, 63, 64	PCI[1:4]	O, SE	<b>33-MHz clock.</b>																														
65	PCI5/FCTSEL1	O, SE PD	<b>33-MHz clock / 3.3 LVTTTL input for selecting for pin 6, 7 (DOT96[T/C], 27M-non-spread and Spread) and pin10,11 (SRC[T/C]0 or 100M[T/C]_SST) (sampled on the VTT_PWRGD# assertion).</b> <table border="1" data-bbox="662 598 1463 762"> <thead> <tr> <th>FCTSEL1</th> <th>FCTSEL0</th> <th>PIN 6</th> <th>PIN 7</th> <th>PIN 10</th> <th>PIN 11</th> </tr> </thead> <tbody> <tr> <td>0</td> <td>0</td> <td>DOT96T</td> <td>DOT96C</td> <td>100MT_SST</td> <td>100MC_SST</td> </tr> <tr> <td>0</td> <td>1</td> <td>DOT96T</td> <td>DOT96C</td> <td>SRCT0</td> <td>SRCC0</td> </tr> <tr> <td>1</td> <td>0</td> <td>27M_non spread</td> <td>27M_Spread</td> <td>SRCT0</td> <td>SRCC0</td> </tr> <tr> <td>1</td> <td>1</td> <td>OFF Low</td> <td>TBD</td> <td>SRCT0</td> <td>SRCC0</td> </tr> </tbody> </table>	FCTSEL1	FCTSEL0	PIN 6	PIN 7	PIN 10	PIN 11	0	0	DOT96T	DOT96C	100MT_SST	100MC_SST	0	1	DOT96T	DOT96C	SRCT0	SRCC0	1	0	27M_non spread	27M_Spread	SRCT0	SRCC0	1	1	OFF Low	TBD	SRCT0	SRCC0
FCTSEL1	FCTSEL0	PIN 6	PIN 7	PIN 10	PIN 11																												
0	0	DOT96T	DOT96C	100MT_SST	100MC_SST																												
0	1	DOT96T	DOT96C	SRCT0	SRCC0																												
1	0	27M_non spread	27M_Spread	SRCT0	SRCC0																												
1	1	OFF Low	TBD	SRCT0	SRCC0																												
68	PCIF0/ITP_SEL	I/O, SE	<b>33-MHz clock output / 3.3V LVTTTL input to enable SRC[T/C]11or CPU[T/C]2_ITP on pin 36, 37. (sampled on the VTT_PWRGD# assertion).</b> 0 = SRC11 (default) 1 = CPU2_ITP,																														
2	VTT_PWRGD#/PD	I, PU	<b>3.3V LVTTTL input. This pin is a level sensitive strobe used to latch the FS[C:A], ITP_SEL, FCTSEL[1:0], SEL_CLKREQ#. After VTT_PWRGD# (active LOW) assertion, this pin becomes a real-time input for asserting power-down (active HIGH).</b>																														
4	FSA/48M	I/O	<b>3.3V-tolerant input for CPU frequency selection / Fixed 48-MHz clock output.</b> Refer to DC Electrical Specification Table for Vil_FS and Vih_FS specifications.																														
6, 7	DOT96T/27M_non spread DOT96C/27M_Spread	O, DIF	<b>Fixed 96-MHz Differential Clock / Single ended 27-MHz clocks.</b> When configured for 27 MHz, only the clock on pin 7 contains spread. Selected via FCTSEL[0:1] at VTT_PWRGD# assertion.																														
8	FSB	I	<b>3.3V-tolerant input for CPU frequency selection.</b> Refer to DC Electrical Specification Table for Vil_FS and Vih_FS specifications																														
10, 11	SRC[T/C]0/ LCD100M[T/C]	O, DIF	<b>100-MHz Differential Serial Reference Clock / 100-MHz LVDS Differential Clock.</b>																														
13,14, 15, 16, 18, 19, 21, 22, 23, 24, 26, 27, 29, 30, 32, 33,	SRC[T/C][1:8]	O, DIF	<b>100-MHz Differential Serial Reference Clocks.</b>																														
9, 20, 25, 34, 59, 60	CLKREQ#[1], [3:6], [8]	I/O, PU	<b>3.3V LVTTTL input for enabling assigned SRC clock (active low)</b>																														
36, 37	CPUT2_ITP/SRCT11, CPUC2_ITP/SRCC11	O, DIF	<b>Selectable differential CPU / SRC clock output.</b> ITP_EN = 0 @ VTT_PWRGD# assertion = SRC11 (default) ITP_EN = 1 @ VTT_PWRGD# assertion = CPU2_ITP																														
38	VDDA	PWR	<b>3.3V power supply for PLL.</b>																														
39	VSSA	GND	<b>Ground for PLL.</b>																														
40	IREF	I	<b>A precision resistor is attached to this pin, which is connected to the internal current reference.</b>																														
41, 42, 44, 45	CPU[T/C][0:1]	O, DIF	<b>Differential CPU clock outputs.</b>																														
47	SCLK	I	<b>SMBus-compatible SCLOCK.</b>																														
48	SDATA	I/O OD	<b>SMBus-compatible SDATA.</b>																														

**Pin Descriptions** (continued)

Pin No.	Name	Type	Description																														
50	XOUT	O, SE	14.318-MHz crystal output.																														
51	XIN	I	14.318-MHz crystal input.																														
53	REF1/FCTSEL0	I/O, SE PD	<p><b>Fixed 14.318-MHz Clock Output / 3.3 LVTTTL input for selecting for pin 6, 7 (DOT96[T/C], 27M-non-spread and Spread) and pin 10,11 (SRC[T/C]0 or 100M[T/C]_SST) (sampled on the VTT_PWRGD# assertion).</b></p> <table border="1"> <thead> <tr> <th>FCTSEL1</th> <th>FCTSEL0</th> <th>PIN 6</th> <th>PIN 7</th> <th>PIN 10</th> <th>PIN 11</th> </tr> </thead> <tbody> <tr> <td>0</td> <td>0</td> <td>DOT96T</td> <td>DOT96C</td> <td>100MT_SST</td> <td>100MC_SST</td> </tr> <tr> <td>0</td> <td>1</td> <td>DOT96T</td> <td>DOT96C</td> <td>SRCT0</td> <td>SRCC0</td> </tr> <tr> <td>1</td> <td>0</td> <td>27M_non spread</td> <td>27M_Spread</td> <td>SRCT0</td> <td>SRCC0</td> </tr> <tr> <td>1</td> <td>1</td> <td>OFF Low</td> <td>TBD</td> <td>SRCT0</td> <td>SRCC0</td> </tr> </tbody> </table>	FCTSEL1	FCTSEL0	PIN 6	PIN 7	PIN 10	PIN 11	0	0	DOT96T	DOT96C	100MT_SST	100MC_SST	0	1	DOT96T	DOT96C	SRCT0	SRCC0	1	0	27M_non spread	27M_Spread	SRCT0	SRCC0	1	1	OFF Low	TBD	SRCT0	SRCC0
FCTSEL1	FCTSEL0	PIN 6	PIN 7	PIN 10	PIN 11																												
0	0	DOT96T	DOT96C	100MT_SST	100MC_SST																												
0	1	DOT96T	DOT96C	SRCT0	SRCC0																												
1	0	27M_non spread	27M_Spread	SRCT0	SRCC0																												
1	1	OFF Low	TBD	SRCT0	SRCC0																												
54	REF0/FSC	I/O	<p><b>Fixed 14.318 MHz clock output / 3.3V-tolerant input for CPU frequency selection.</b> Refer to DC Electrical Specification Table for VilFS_C, VimFS_C and VihFS_C specifications</p>																														
55	CPU_STP#	I, PU	<b>3.3V LVTTTL input for CPU_STP# active LOW.</b>																														
56	PCI_STP#	I, PU	<b>3.3V LVTTTL input for PCI_STP# active LOW.</b>																														

**Table 1. Frequency Select Table FSA, FSB and FSC**

FSC	FSB	FSA	CPU	SRC	PCIF/PCI	27MHz	REF0	DOT96	USB
1	0	1	100 MHz	100 MHz	33 MHz	27 MHz	14.318 MHz	96 MHz	48 MHz
0	0	1	133 MHz	100 MHz	33 MHz	27 MHz	14.318 MHz	96 MHz	48 MHz
0	1	1	166 MHz	100 MHz	33 MHz	27 MHz	14.318 MHz	96 MHz	48 MHz
0	1	0	200 MHz	100 MHz	33 MHz	27 MHz	14.318 MHz	96 MHz	48 MHz

### Frequency Select Pins (FSA, FSB, and FSC)

Host clock frequency selection is achieved by applying the appropriate logic levels to FSA, FSB, FSC inputs prior to VTT\_PWRGD# assertion (as seen by the clock synthesizer). Upon VTT\_PWRGD# being sampled low by the clock chip (indicating processor VTT voltage is stable), the clocking chip samples the FSA, FSB, and FSC input values. For all logic levels of FSA, FSB, and FSC, VTT\_PWRGD# employs a one-shot functionality in that once a valid low on VTT\_PWRGD# has been sampled, all further VTT\_PWRGD#, FSA, FSB, and FSC transitions will be ignored, except in test mode.

### Serial Data Interface

To enhance the flexibility and function of the clock synthesizer, a two-signal serial interface is provided. Through the Serial Data Interface, various device functions, such as individual clock output buffers, can be individually enabled or disabled. The registers associated with the Serial Data Interface

initialize to their default setting upon power-up, and therefore use of this interface is optional. Clock device register changes are normally made upon system initialization, if any are required. The interface cannot be used during system operation for power management functions.

### Data Protocol

The clock driver serial protocol accepts byte write, byte read, block write, and block read operations from the controller. For block write/read operation, the bytes must be accessed in sequential order from lowest to highest byte (most significant bit first) with the ability to stop after any complete byte has been transferred. For byte write and byte read operations, the system controller can access individually indexed bytes. The offset of the indexed byte is encoded in the command code, as described in *Table 2*.

The block write and block read protocol is outlined in *Table 3* while *Table 4* outlines the corresponding byte write and byte read protocol. The slave receiver address is 11010010 (D2h).

**Table 2. Command Code Definition**

Bit	Description
7	0 = Block read or block write operation, 1 = Byte read or byte write operation
(6:0)	Byte offset for byte read or byte write operation. For block read or block write operations, these bits should be '0000000'

**Table 3. Block Read and Block Write Protocol**

Block Write Protocol		Block Read Protocol	
Bit	Description	Bit	Description
1	Start	1	Start
8:2	Slave address – 7 bits	8:2	Slave address – 7 bits
9	Write	9	Write
10	Acknowledge from slave	10	Acknowledge from slave
18:11	Command Code – 8 bits	18:11	Command Code – 8 bits
19	Acknowledge from slave	19	Acknowledge from slave
27:20	Byte Count – 8 bits (Skip this step if I <sup>2</sup> C_EN bit set)	20	Repeat start
28	Acknowledge from slave	27:21	Slave address – 7 bits
36:29	Data byte 1 – 8 bits	28	Read = 1
37	Acknowledge from slave	29	Acknowledge from slave
45:38	Data byte 2 – 8 bits	37:30	Byte Count from slave – 8 bits
46	Acknowledge from slave	38	Acknowledge
....	Data Byte /Slave Acknowledges	46:39	Data byte 1 from slave – 8 bits
....	Data Byte N – 8 bits	47	Acknowledge
....	Acknowledge from slave	55:48	Data byte 2 from slave – 8 bits

**Table 3. Block Read and Block Write Protocol (continued)**

Block Write Protocol		Block Read Protocol	
Bit	Description	Bit	Description
....	Stop	56	Acknowledge
		....	Data bytes from slave / Acknowledge
		....	Data Byte N from slave – 8 bits
		....	NOT Acknowledge
		....	Stop

**Table 4. Byte Read and Byte Write Protocol**

Byte Write Protocol		Byte Read Protocol	
Bit	Description	Bit	Description
1	Start	1	Start
8:2	Slave address – 7 bits	8:2	Slave address – 7 bits
9	Write	9	Write
10	Acknowledge from slave	10	Acknowledge from slave
18:11	Command Code – 8 bits	18:11	Command Code – 8 bits
19	Acknowledge from slave	19	Acknowledge from slave
27:20	Data byte – 8 bits	20	Repeated start
28	Acknowledge from slave	27:21	Slave address – 7 bits
29	Stop	28	Read
		29	Acknowledge from slave
		37:30	Data from slave – 8 bits
		38	NOT Acknowledge
		39	Stop

**Control Registers**
**Byte 0: Control Register 0**

Bit	@Pup	Name	Description
7	1	SRC[T/C]7	SRC[T/C]7 Output Enable 0 = Disable (Tri-state), 1 = Enable
6	1	SRC[T/C]6	SRC[T/C]6 Output Enable 0 = Disable (Tri-state), 1 = Enable
5	1	SRC[T/C]5	SRC[T/C]5 Output Enable 0 = Disable (Tri-state), 1 = Enable
4	1	SRC[T/C]4	SRC[T/C]4 Output Enable 0 = Disable (Tri-state), 1 = Enable
3	1	SRC[T/C]3	SRC[T/C]3 Output Enable 0 = Disable (Tri-state), 1 = Enable
2	1	SRC[T/C]2	SRC[T/C]2 Output Enable 0 = Disable (Tri-state), 1 = Enable
1	1	SRC[T/C]1	SRC[T/C]1 Output Enable 0 = Disable (Tri-state), 1 = Enable
0	1	SRC[T/C]0 /LCD100M[T/C]	SRC[T/C]0 /LCD100M[T/C] Output Enable 0 = Disable (Hi-Z), 1 = Enable

**Byte 1: Control Register 1**

Bit	@Pup	Name	Description
7	1	PCIF0	PCIF0 Output Enable 0 = Disabled, 1 = Enabled
6	1	DOT_96[T/C]	DOT_96 MHz Output Enable 0 = Disable (Tri-state), 1 = Enabled
5	1	USB_48MHz	USB_48M MHz Output Enable 0 = Disabled, 1 = Enabled
4	1	REF0	REF0 Output Enable 0 = Disabled, 1 = Enabled
3	1	REF1	REF1 Output Enable 0 = Disabled, 1 = Enabled
2	1	CPU[T/C]1	CPU[T/C]1 Output Enable 0 = Disable (Tri-state), 1 = Enabled
1	1	CPU[T/C]0	CPU[T/C]0 Output Enable 0 = Disable (Tri-state), 1 = Enabled
0	0	CPU	PLL1 (CPU PLL) Spread Spectrum Enable 0 = Spread off, 1 = Spread on

**Byte 2: Control Register 2**

Bit	@Pup	Name	Description
7	1	PCI5	PCI5 Output Enable 0 = Disabled, 1 = Enabled
6	1	PCI4	PCI4 Output Enable 0 = Disabled, 1 = Enabled
5	1	PCI3	PCI3 Output Enable 0 = Disabled, 1 = Enabled
4	1	PCI2	PCI2 Output Enable 0 = Disabled, 1 = Enabled
3	1	PCI1	PCI1 Output Enable 0 = Disabled, 1 = Enabled
2	1	RESERVED	RESERVED
1	1	CPU[T/C]2	CPU[T/C]2 Output Enable 0 = Disabled (Hi-Z), 1 = Enabled
0	1	RESERVED	RESERVED

**Byte 3: Control Register 3**

Bit	@Pup	Name	Description
7	0	SRC7	Allow control of SRC[T/C]7 with assertion of PCI_STP# or SW PCI_STP# 0 = Free running, 1 = Stopped with PCI_STP#
6	0	SRC6	Allow control of SRC[T/C]6 with assertion of PCI_STP# or SW PCI_STP# 0 = Free running, 1 = Stopped with PCI_STP#
5	0	SRC5	Allow control of SRC[T/C]5 with assertion of PCI_STP# or SW PCI_STP# 0 = Free running, 1 = Stopped with PCI_STP#
4	0	SRC4	Allow control of SRC[T/C]4 with assertion of PCI_STP# or SW PCI_STP# 0 = Free running, 1 = Stopped with PCI_STP#
3	0	SRC3	Allow control of SRC[T/C]3 with assertion of PCI_STP# or SW PCI_STP# 0 = Free running, 1 = Stopped with PCI_STP#
2	0	SRC2	Allow control of SRC[T/C]2 with assertion of PCI_STP# or SW PCI_STP# 0 = Free running, 1 = Stopped with PCI_STP#
1	0	SRC1	Allow control of SRC[T/C]1 with assertion of PCI_STP# or SW PCI_STP# 0 = Free running, 1 = Stopped with PCI_STP#
0	0	SRC0	Allow control of SRC[T/C]0 with assertion of PCI_STP# or SW PCI_STP# 0 = Free running, 1 = Stopped with PCI_STP#

**Byte 4: Control Register 4**

Bit	@Pup	Name	Description
7	0	LCD100M[T/C]	LCD100M[T/C] PWRDWN Drive Mode 0 = Driven in PWRDWN, 1 = Tri-state
6	0	DOT96[T/C]	DOT PWRDWN Drive Mode 0 = Driven in PWRDWN, 1 = Tri-state
5	1	SRC[T/C]	SRC[T/C] Stop Drive Mode when CLKREQ# asserted 0 = Driven, 1 = Tri-state
4	0	RESERVED	RESERVED
3	0	PCIF0	Allow control of PCIF0 with assertion of SW and HW PCI_STP# 0 = Free running, 1 = Stopped with PCI_STP#
2	1	CPU[T/C]2	Allow control of CPU[T/C]2 with assertion of CPU_STP# 0 = Free running, 1 = Stopped with CPU_STP#
1	1	CPU[T/C]1	Allow control of CPU[T/C]1 with assertion of CPU_STP# 0 = Free running, 1 = Stopped with CPU_STP#
0	1	CPU[T/C]0	Allow control of CPU[T/C]0 with assertion of CPU_STP# 0 = Free running, 1 = Stopped with CPU_STP#

**Byte 5: Control Register 5**

Bit	@Pup	Name	Description
7	0	SRC[T/C]	SRC[T/C] Stop Drive Mode 0 = Driven when PCI_STP# asserted, 1 = Tri-state when PCI_STP# asserted
6	0	CPU[T/C]2	CPU[T/C]2 Stop Drive Mode 0 = Driven when CPU_STP# asserted, 1 = Tri-state when CPU_STP# asserted
5	0	CPU[T/C]1	CPU[T/C]1 Stop Drive Mode 0 = Driven when CPU_STP# asserted, 1 = Tri-state when CPU_STP# asserted
4	0	CPU[T/C]0	CPU[T/C]0 Stop Drive Mode 0 = Driven when CPU_STP# asserted, 1 = Tri-state when CPU_STP# asserted
3	0	SRC[T/C]	SRC[T/C] PWRDWN Drive Mode 0 = Driven when PD asserted, 1 = Tri-state when PD asserted

**Byte 5: Control Register 5 (continued)**

Bit	@Pup	Name	Description
2	0	CPU[T/C]2	CPU[T/C]2 PWRDWN Drive Mode 0 = Driven when PD asserted, 1 = Tri-state when PD asserted
1	0	CPU[T/C]1	CPU[T/C]1 PWRDWN Drive Mode 0 = Driven when PD asserted, 1 = Tri-state when PD asserted
0	0	CPU[T/C]0	CPU[T/C]0 PWRDWN Drive Mode 0 = Driven when PD asserted, 1 = Tri-state when PD asserted

**Byte 6: Control Register 6**

Bit	@Pup	Name	Description
7	0	TEST_SEL	REF/N or Tri-state Select 0 = Tri-state, 1 = REF/N Clock
6	0	TEST_MODE	Test Clock Mode Entry Control 0 = Normal operation, 1 = REF/N or Tri-state mode,
5	1	REF1	REF0 Output Drive Strength 0 = Low, 1 = High
4	1	REF0	REF0 Output Drive Strength 0 = Low, 1 = High
3	1	PCI, PCIF and SRC clock outputs except those set to free running	SW PCI_STP Function 0=SW PCI_STP assert, 1= SW PCI_STP deassert When this bit is set to 0, all STOPPABLE PCI, PCIF and SRC outputs will be stopped in a synchronous manner with no short pulses. When this bit is set to 1, all STOPPED PCI, PCIF and SRC outputs will resume in a synchronous manner with no short pulses.
2	HW	FSC	FSC Reflects the value of the FSC pin sampled on power-up 0 = FSC was low during VTT_PWRGD# assertion
1	HW	FSB	FSB Reflects the value of the FSB pin sampled on power-up 0 = FSB was low during VTT_PWRGD# assertion
0	HW	FSA	FSA Reflects the value of the FSA pin sampled on power-up 0 = FSA was low during VTT_PWRGD# assertion

**Byte 7: Vendor ID**

Bit	@Pup	Name	Description
7	0	Revision Code Bit 3	Revision Code Bit 3
6	0	Revision Code Bit 2	Revision Code Bit 2
5	0	Revision Code Bit 1	Revision Code Bit 1
4	0	Revision Code Bit 0	Revision Code Bit 0
3	1	Vendor ID Bit 3	Vendor ID Bit 3
2	0	Vendor ID Bit 2	Vendor ID Bit 2
1	0	Vendor ID Bit 1	Vendor ID Bit 1
0	0	Vendor ID Bit 0	Vendor ID Bit 0

**Byte 8: Control Register 8**

Bit	@Pup	Name	Description
7	0	CPU_SS	0: -0.5% (Peak to peak) 1: -1.0% (Peak to peak)
6	0	CPU-DWN_SS	0: Down Spread 1: Center Spread
5	0	RESERVED	RESERVED, Set = 0
4	0	RESERVED	RESERVED, Set = 0
3	0	RESERVED	RESERVED, Set = 0



**Byte 8: Control Register 8 (continued)**

Bit	@Pup	Name	Description
2	1	48M	48-MHz Output Drive Strength 0 = Low, 1 = High
1	1	PCI5	33-MHz Output Drive Strength 0 = Low, 1 = High
0	1	PCIF0	33-MHz Output Drive Strength 0 = Low, 1 = High

**Byte 9: Control Register 9**

Bit	@Pup	Name	Description
7	0	S3	27_96_100_SSC Spread Spectrum Selection table: S[3:0] SS%
6	0	S2	
5	0	S1	
4	0	S0	
			'0000' = -0.45%(Default value)
			'0001' = -0.9%
			'0010' = -1.45%
			'0011' = -1.9%
			'0100' = ±0.225%
			'0101' = ±0.45%
			'0110' = ±0.725%
			'0111' = ±0.95%
			'1000' = -0.34%
			'1001' = -0.68%
			'1010' = -1.09%
			'1011' = -1.425%
			'1100' = ±0.17%
			'1101' = ±0.34%
			'1110' = ±0.545%
			'1111' = ±0.712%
3	1	RESERVED	RESERVED, Set = 1
2	1	27_M Spread	27_MHz Spread Output Enable 0 = Disable (Hi-Z), 1 = Enable.
1	0	27_LCD100M SS Enable	27_LCD100M Spread Spectrum Enable. 0 = Disable, 1 = Enable.
0	1	Reserved	Reserved

**Byte 10: Control Register 10**

Bit	@Pup	Name	Description
7	1	SRC[T/C]11	SRC[T/C]11 Output Enable 0 = Disable (Hi-Z), 1 = Enable
6	1	RESERVED	RESERVED
5	1	RESERVED	RESERVED
4	1	SRC[T/C]8	SRC[T/C]8 Output Enable 0 = Disable (Hi-Z), 1 = Enable
3	0	SRC[T/C]11	Allow control of SRC[T/C]11 with assertion of SW PCI_STP# 0 = Free running, 1 = Stopped with PCI_STP#
2	0	RESERVED	RESERVED
1	0	RESERVED	RESERVED

**Byte 10: Control Register 10 (continued)**

Bit	@Pup	Name	Description
0	0	SRC[T/C]8	Allow control of SRC[T/C]8 with assertion of SW PCI_STP# 0 = Free running, 1 = Stopped with PCI_STP#

**Byte 11: Control Register 11**

Bit	@Pup	Name	Description
7	0	DIAG_EN	Setting this bit to 0 = Reset (Default) Setting forces Bit 6, 5, 4, 0 to zero 1 = DIAG Mode enabled
6	HW	CPU_PLL	CPU PLL Status 0 = PLL not locked, 1 = PLL locked Read only bit 7 sets to 0 when Bit 7 = 0
5	HW	Video_PLL	Video PLL Status 0 = PLL not locked, 1 = PLL locked Read only bit 7 sets to 0 when Bit 7 = 0
4	HW	Fixed_PLL	Fixed PLL Status 0 = PLL not locked, 1 = PLL locked Read only bit 7 sets to 0 when Bit 7 = 0
3	1	27M_non Spread output drive strength	27M (Spread and Non-spread) Output Drive Strength 0 = Low, 1 = High
2	0	RESERVED	RESERVED
1	0	RESERVED	RESERVED
0	HW	PWRGOOD	Power Status Bit 0 = All of the below conditions are not met 1 = Valid voltage levels exists on VDD_SRC, VDD_CPU, and VDD_REF, and VTPWRGD# has been asserted, and a clock edge is detected on Xin. Read only bit 7 sets to 0 when bit 7 = 0

**Byte 12: Control Register 12**

Bit	@Pup	Name	Description
7	1	Reserved	Reserved
6	1	CLKREQ#8	CLKREQ#8 Input Enable 0 = Disable 1 = Enable
5	1	Reserved	Reserved
4	1	CLKREQ#6	CLKREQ#6 Input Enable 0 = Disable 1 = Enable
3	1	CLKREQ#5	CLKREQ#5 Input Enable 0 = Disable 1 = Enable
2	1	CLKREQ#4	CLKREQ#4 Input Enable 0 = Disable 1 = Enable
1	1	CLKREQ#3	CLKREQ#3 Input Enable 0 = Disable 1 = Enable
0	1	Reserved	Reserved

**Byte 13: Control Register 13**

Bit	@Pup	Name	Description
7	1	CLKREQ#1	CLKREQ#1 Input Enable 0 = Disable 1 = Enable
6	1	RESERVED	RESERVED
5	1	27M non Spread	27M non Spread Output Enable 0 = Disable 1 = Enable
4	1	27M Spread	27M Spread Output Drive Strength 0 = Low 1 = High

**Byte 13: Control Register 13 (continued)**

Bit	@Pup	Name	Description
3	1	PCI4	PCI4 (Spread and Non-spread) Output Drive Strength 0 = Low, 1 = High
2	1	PCI3	PCI3 (Spread and Non-spread) Output Drive Strength 0 = Low, 1 = High
1	1	PCI2	PCI2 (Spread and Non-spread) Output Drive Strength 0 = Low, 1 = High
0	1	PCI1	PCI1 (Spread and Non-spread) Output Drive Strength 0 = Low, 1 = High

**Byte 14: Control Register 14**

Bit	@Pup	Name	Description
7	1	RESERVED	RESERVED
6	0	RESERVED	RESERVED
5	0	RESERVED	RESERVED
4	0	RESERVED	RESERVED
3	0	RESERVED	RESERVED
2	0	RESERVED	RESERVED
1	0	RESERVED	RESERVED
0	0	RESERVED	RESERVED

**Byte 15: Control Register 15**

Bit	@Pup	Name	Description
7	1	CLKREQ#8	SRC[T/C]8 Control 0 = SRC[T/C]8 not stoppable by CLKREQ#8 1 = SRC[T/C]8 stoppable by CLKREQ#8
6	0	CLKREQ#8	SRC[T/C]7 Control 0 = SRC[T/C]7 not stoppable by CLKREQ#8 1 = SRC[T/C]7 stoppable by CLKREQ#8
5	0	CLKREQ#8	SRC[T/C]6 Control 0 = SRC[T/C]6 not stoppable by CLKREQ#8 1 = SRC[T/C]6 stoppable by CLKREQ#8
4	0	CLKREQ#8	SRC[T/C]5 Control 0 = SRC[T/C]5 not stoppable by CLKREQ#8 1 = SRC[T/C]5 stoppable by CLKREQ#8
3	0	CLKREQ#8	SRC[T/C]4 Control 0 = SRC[T/C]4 not stoppable by CLKREQ#8 1 = SRC[T/C]4 stoppable by CLKREQ#8
2	0	CLKREQ#8	SRC[T/C]3 Control 0 = SRC[T/C]3 not stoppable by CLKREQ#8 1 = SRC[T/C]3 stoppable by CLKREQ#8
1	0	CLKREQ#8	SRC[T/C]2 Control 0 = SRC[T/C]2 not stoppable by CLKREQ#8 1 = SRC[T/C]2 stoppable by CLKREQ#8
0	0	CLKREQ#8	SRC[T/C]1 Control 0 = SRC[T/C]1 not stoppable by CLKREQ#8 1 = SRC[T/C]1 stoppable by CLKREQ#8

**Byte 16: Control Register 16**

Bit	@Pup	Name	Description
7	0	CLKREQ#5	SRC[T/C]8 Control 0 = SRC[T/C]8 not stoppable by CLKREQ#5 1 = SRC[T/C]8 stoppable by CLKREQ#5
6	0	CLKREQ#5	SRC[T/C]7 Control 0 = SRC[T/C]7 not stoppable by CLKREQ#5 1 = SRC[T/C]7 stoppable by CLKREQ#5
5	0	CLKREQ#5	SRC[T/C]6 Control 0 = SRC[T/C]6 not stoppable by CLKREQ#5 1 = SRC[T/C]6 stoppable by CLKREQ#5
4	1	CLKREQ#5	SRC[T/C]5 Control 0 = SRC[T/C]5 not stoppable by CLKREQ#5 1 = SRC[T/C]5 stoppable by CLKREQ#5
3	0	CLKREQ#5	SRC[T/C]4 Control 0 = SRC[T/C]4 not stoppable by CLKREQ#5 1 = SRC[T/C]4 stoppable by CLKREQ#5
2	0	CLKREQ#5	SRC[T/C]3 Control 0 = SRC[T/C]3 not stoppable by CLKREQ#5 1 = SRC[T/C]3 stoppable by CLKREQ#5
1	0	CLKREQ#5	SRC[T/C]2 Control 0 = SRC[T/C]2 not stoppable by CLKREQ#5 1 = SRC[T/C]2 stoppable by CLKREQ#5
0	0	CLKREQ#5	SRC[T/C]1 Control 0 = SRC[T/C]1 not stoppable by CLKREQ#5 1 = SRC[T/C]1 stoppable by CLKREQ#5

**Byte 17: Control Register 17**

Bit	@Pup	Name	Description
7	0	CLKREQ#4	SRC[T/C]8 Control 0 = SRC[T/C]8 not stoppable by CLKREQ#4 1 = SRC[T/C]8 stoppable by CLKREQ#4
6	0	CLKREQ#4	SRC[T/C]7 Control 0 = SRC[T/C]7 not stoppable by CLKREQ#4 1 = SRC[T/C]7 stoppable by CLKREQ#4
5	0	CLKREQ#4	SRC[T/C]6 Control 0 = SRC[T/C]6 not stoppable by CLKREQ#4 1 = SRC[T/C]6 stoppable by CLKREQ#4
4	0	CLKREQ#4	SRC[T/C]5 Control 0 = SRC[T/C]5 not stoppable by CLKREQ#4 1 = SRC[T/C]5 stoppable by CLKREQ#4
3	1	CLKREQ#4	SRC[T/C]4 Control 0 = SRC[T/C]4 not stoppable by CLKREQ#4 1 = SRC[T/C]4 stoppable by CLKREQ#4
2	0	CLKREQ#4	SRC[T/C]3 Control 0 = SRC[T/C]3 not stoppable by CLKREQ#4 1 = SRC[T/C]3 stoppable by CLKREQ#4
1	0	CLKREQ#4	SRC[T/C]2 Control 0 = SRC[T/C]2 not stoppable by CLKREQ#4 1 = SRC[T/C]2 stoppable by CLKREQ#4
0	0	CLKREQ#4	SRC[T/C]1 Control 0 = SRC[T/C]1 not stoppable by CLKREQ#4 1 = SRC[T/C]1 stoppable by CLKREQ#4

**Byte 18: Control Register 18**

Bit	@Pup	Name	Description
7	0	CLKREQ#3	SRC[T/C]8 Control 0 = SRC[T/C]8 not stoppable by CLKREQ#3 1 = SRC[T/C]8 stoppable by CLKREQ#3
6	0	CLKREQ#3	SRC[T/C]7 Control 0 = SRC[T/C]7 not stoppable by CLKREQ#3 1 = SRC[T/C]7 stoppable by CLKREQ#3
5	0	CLKREQ#3	SRC[T/C]6 Control 0 = SRC[T/C]6 not stoppable by CLKREQ#3 1 = SRC[T/C]6 stoppable by CLKREQ#3
4	0	CLKREQ#3	SRC[T/C]5 Control 0 = SRC[T/C]5 not stoppable by CLKREQ#3 1 = SRC[T/C]5 stoppable by CLKREQ#3
3	0	CLKREQ#3	SRC[T/C]4 Control 0 = SRC[T/C]4 not stoppable by CLKREQ#3 1 = SRC[T/C]4 stoppable by CLKREQ#3
2	1	CLKREQ#3	SRC[T/C]3 Control 0 = SRC[T/C]3 not stoppable by CLKREQ#3 1 = SRC[T/C]3 stoppable by CLKREQ#3
1	0	CLKREQ#3	SRC[T/C]2 Control 0 = SRC[T/C]2 not stoppable by CLKREQ#3 1 = SRC[T/C]2 stoppable by CLKREQ#3
0	0	CLKREQ#3	SRC[T/C]1 Control 0 = SRC[T/C]1 not stoppable by CLKREQ#3 1 = SRC[T/C]1 stoppable by CLKREQ#3

**Byte 19: Control Register 19**

Bit	@Pup	Name	Description
7	0	CLKREQ#1	SRC[T/C]8 Control 0 = SRC[T/C]8 not stoppable by CLKREQ#1 1 = SRC[T/C]8 stoppable by CLKREQ#1
6	0	CLKREQ#1	SRC[T/C]7 Control 0 = SRC[T/C]7 not stoppable by CLKREQ#1 1 = SRC[T/C]7 stoppable by CLKREQ#1
5	0	CLKREQ#1	SRC[T/C]6 Control 0 = SRC[T/C]6 not stoppable by CLKREQ#1 1 = SRC[T/C]6 stoppable by CLKREQ#1
4	0	CLKREQ#1	SRC[T/C]5 Control 0 = SRC[T/C]5 not stoppable by CLKREQ#1 1 = SRC[T/C]5 stoppable by CLKREQ#1
3	0	CLKREQ#1	SRC[T/C]4 Control 0 = SRC[T/C]4 not stoppable by CLKREQ#1 1 = SRC[T/C]4 stoppable by CLKREQ#1
2	0	CLKREQ#1	SRC[T/C]3 Control 0 = SRC[T/C]3 not stoppable by CLKREQ#1 1 = SRC[T/C]3 stoppable by CLKREQ#1
1	0	CLKREQ#1	SRC[T/C]2 Control 0 = SRC[T/C]2 not stoppable by CLKREQ#1 1 = SRC[T/C]2 stoppable by CLKREQ#1
0	1	CLKREQ#1	SRC[T/C]1 Control 0 = SRC[T/C]1 not stoppable by CLKREQ#1 1 = SRC[T/C]1 stoppable by CLKREQ#1

**Table 5. Crystal Recommendations**

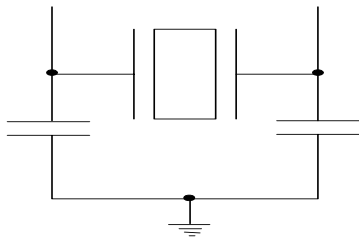
Frequency (Fund)	Cut	Loading	Load Cap	Drive (max.)	Shunt Cap (max.)	Motional (max.)	Tolerance (max.)	Stability (max.)	Aging (max.)
14.31818 MHz	AT	Parallel	20 pF	0.1 mW	5 pF	0.016 pF	35 ppm	30 ppm	5 ppm

The CY28445-5 requires a Parallel Resonance Crystal. Substituting a series resonance crystal will cause the CY28445-5 to operate at the wrong frequency and violate the ppm specification. For most applications there is a 300-ppm frequency shift between series and parallel crystals due to incorrect loading.

### Crystal Loading

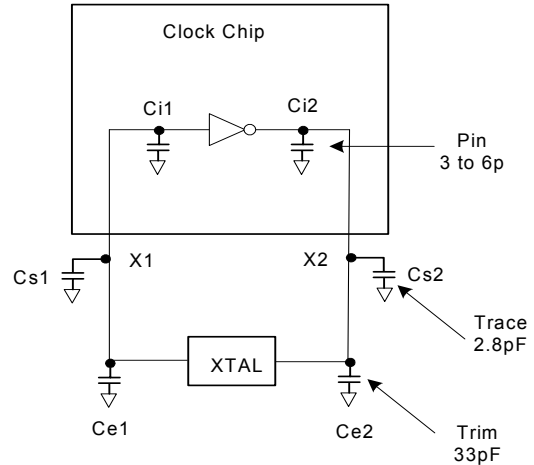
Crystal loading plays a critical role in achieving low ppm performance. To realize low ppm performance, the total capacitance the crystal will see must be considered to calculate the appropriate capacitive loading (CL).

Figure 1 shows a typical crystal configuration using the two trim capacitors. An important clarification for the following discussion is that the trim capacitors are in series with the crystal not parallel. It's a common misconception that load capacitors are in parallel with the crystal and should be approximately equal to the load capacitance of the crystal. This is not true.


**Figure 1. Crystal Capacitive Clarification**

### Calculating Load Capacitors

In addition to the standard external trim capacitors, trace capacitance and pin capacitance must also be considered to correctly calculate crystal loading. As mentioned previously, the capacitance on each side of the crystal is in series with the crystal. This means the total capacitance on each side of the crystal must be twice the specified crystal load capacitance (CL). While the capacitance on each side of the crystal is in series with the crystal, trim capacitors (Ce1,Ce2) should be calculated to provide equal capacitive loading on both sides.


**Figure 2. Crystal Loading Example**

As mentioned previously, the capacitance on each side of the crystal is in series with the crystal. This means the total capacitance on each side of the crystal must be twice the specified load capacitance (CL). While the capacitance on each side of the crystal is in series with the crystal, trim capacitors (Ce1,Ce2) should be calculated to provide equal capacitance loading on both sides.

Use the following formulas to calculate the trim capacitor values for Ce1 and Ce2.

#### Load Capacitance (each side)

$$C_e = 2 * CL - (C_s + C_i)$$

#### Total Capacitance (as seen by the crystal)

$$CL_e = \frac{1}{\left( \frac{1}{C_{e1} + C_{s1} + C_{i1}} + \frac{1}{C_{e2} + C_{s2} + C_{i2}} \right)}$$

- CL .....Crystal load capacitance
- CL<sub>e</sub> ..... Actual loading seen by crystal using standard value trim capacitors
- C<sub>e</sub> ..... External trim capacitors
- C<sub>s</sub> ..... Stray capacitance (terraced)
- C<sub>i</sub> ..... Internal capacitance (lead frame, bond wires etc.)
- CL .....Crystal load capacitance
- CL<sub>e</sub> ..... Actual loading seen by crystal using standard value trim capacitors
- C<sub>e</sub> ..... External trim capacitors
- C<sub>s</sub> ..... Stray capacitance (terraced)
- C<sub>i</sub> ..... Internal capacitance (lead frame, bond wires etc.)

### CLK\_REQ# Description

The CLKREQ# signals are active LOW inputs used for clean enabling and disabling selected SRC outputs. The outputs controlled by CLKREQ# are determined by the settings in register byte 8. The CLKREQ# signal is a de-bounced signal in that its state must remain unchanged during two consecutive rising edges of SRCC to be recognized as a valid assertion or deassertion. (The assertion and deassertion of this signal is absolutely asynchronous.)

### CLK\_REQ# Assertion (CLKREQ# -> LOW)

All differential outputs that were stopped are to resume normal operation in a glitch free manner. The maximum latency from the assertion to active outputs is between 2–6 SRC clock periods (2 clocks are shown) with all SRC outputs resuming simultaneously. All stopped SRC outputs must be driven high within 10 ns of CLKREQ# deassertion to a voltage greater than 200 mV.

### CLK\_REQ# Deassertion (CLKREQ# -> HIGH)

The impact of deasserting the CLKREQ# pins is all SRC outputs that are set in the control registers to stoppable via deassertion of CLKREQ# are to be stopped after their next transition. The final state of all stopped DIF signals is low, both SRCT clock and SRCC clock outputs will not be driven.

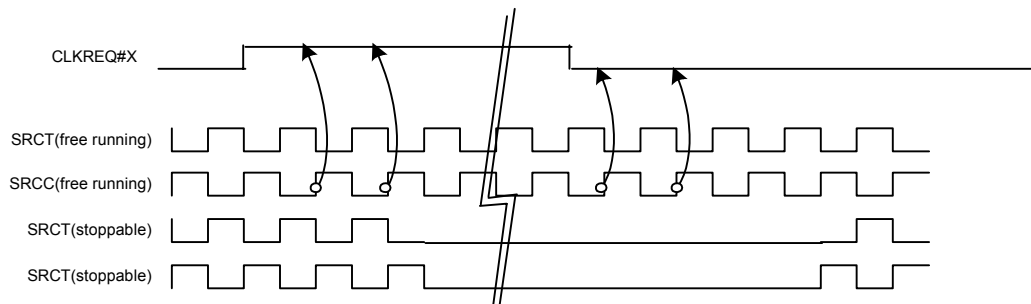
### PD (Power-down) Clarification

The VTT\_PWRGD# /PD pin is a dual-function pin. During initial power-up, the pin functions as VTT\_PWRGD#. Once

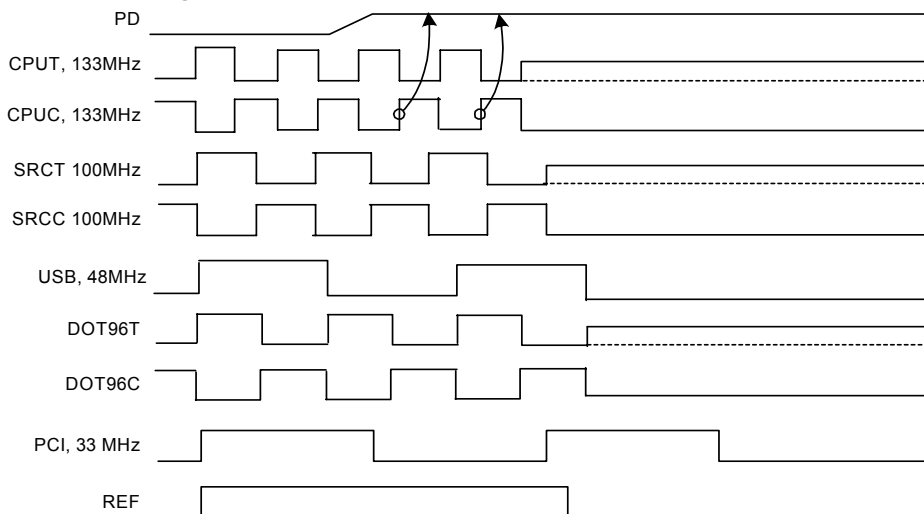
VTT\_PWRGD# has been sampled low by the clock chip, the pin assumes PD functionality. The PD pin is an asynchronous active high input used to shut off all clocks cleanly prior to shutting off power to the device. This signal is synchronized internal to the device prior to powering down the clock synthesizer. PD is also an asynchronous input for powering up the system. When PD is asserted high, all clocks need to be driven to a low value and held prior to turning off the VCOs and the crystal oscillator.

### PD (Power-down) – Assertion

When PD is sampled high by two consecutive rising edges of CPUC, all single-ended outputs will be held low on their next high to low transition and differential clocks must held high or tri-stated (depending on the state of the control register drive mode bit) on the next diff clock# high to low transition within 4 clock periods. When the SMBus PD drive mode bit corresponding to the differential (CPU, SRC, and DOT) clock output of interest is programmed to '0', the clock output are held with "Diff clock" pin driven high at 2 x Iref, and "Diff clock#" tristate. If the control register PD drive mode bit corresponding to the output of interest is programmed to "1", then both the "Diff clock" and the "Diff clock#" are tristate. Note the example below shows CPUC = 133 MHz and PD drive mode = '1' for all differential outputs. This diagram and description is applicable to valid CPU frequencies 100, 133, 166, and 200 MHz. In the event that PD mode is desired as the initial power-on state, PD must be asserted high in less than 10 μs after asserting Vtt\_PwrGd#. It should be noted that 96\_100\_SSC will follow the DOT waveform is selected for 96 MHz and the SRC waveform when in 100-MHz mode.



**Figure 3. CLK\_REQ# Deassertion/Assertion Waveform**



**Figure 4. Power-down Assertion Timing Waveform**

**PD Deassertion**

The power-up latency is less than 1.8 ms. This is the time from the deassertion of the PD pin or the ramping of the power supply until the time that stable clocks are output from the clock chip. All differential outputs stopped in a three-state condition resulting from power down will be driven high in less than 300  $\mu$ s of PD deassertion to a voltage greater than 200 mV. After the clock chip's internal PLL is powered up and locked, all outputs will be enabled within a few clock cycles of each other. Below is an example showing the relationship of clocks coming up. It should be noted that 96\_100\_SSC will follow the DOT waveform is selected for 96 MHz and the SRC waveform when in 100 MHz mode.

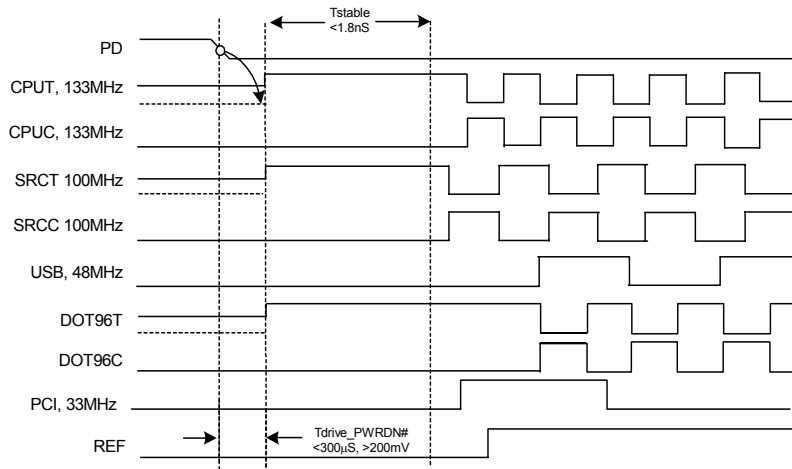
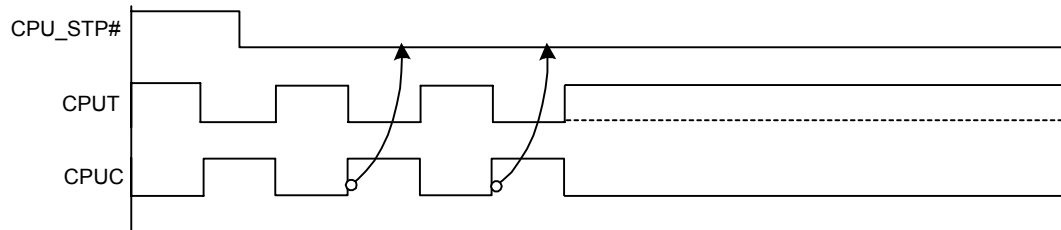
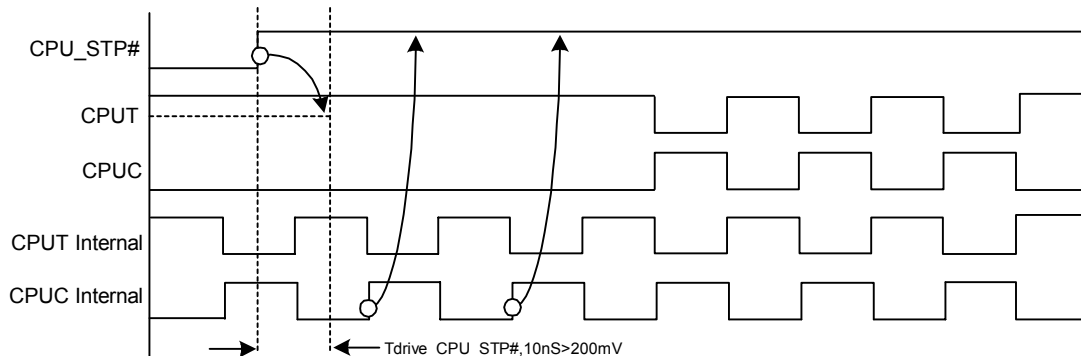
**CPU\_STP# Assertion**

The CPU\_STP# signal is an active low input used for synchronous stopping and starting the CPU output clocks while the rest of the clock generator continues to function.

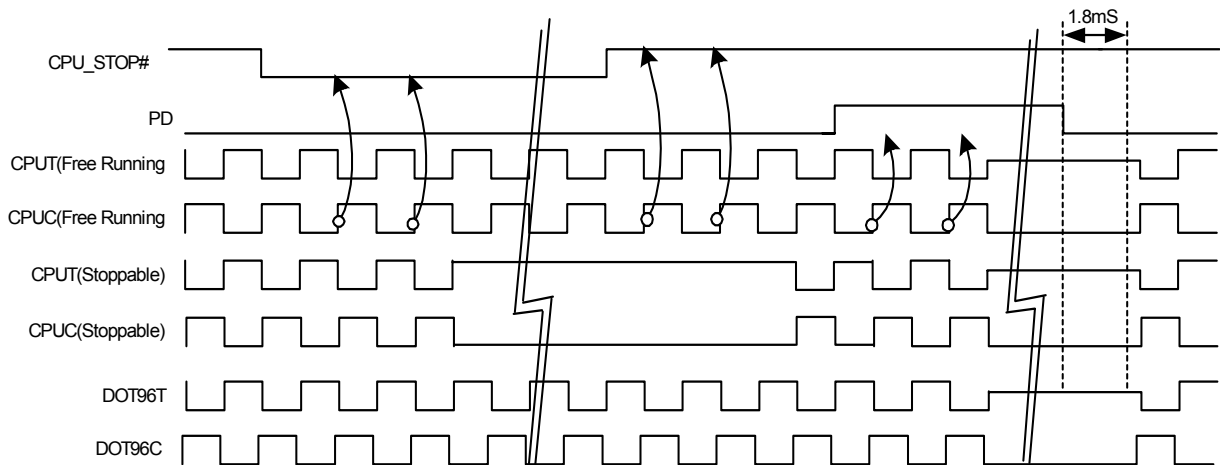
When the CPU\_STP# pin is asserted, all CPU outputs that are set with the SMBus configuration to be stoppable via assertion of CPU\_STP# will be stopped within two–six CPU clock periods after being sampled by two rising edges of the internal CPUC clock. The final states of the stopped CPU signals are CPUT = HIGH and CPUC = LOW. There is no change to the output drive current values during the stopped state. The CPUT is driven HIGH with a current value equal to 6 x (Iref), and the CPUC signal will be Tri-stated.

**CPU\_STP# Deassertion**

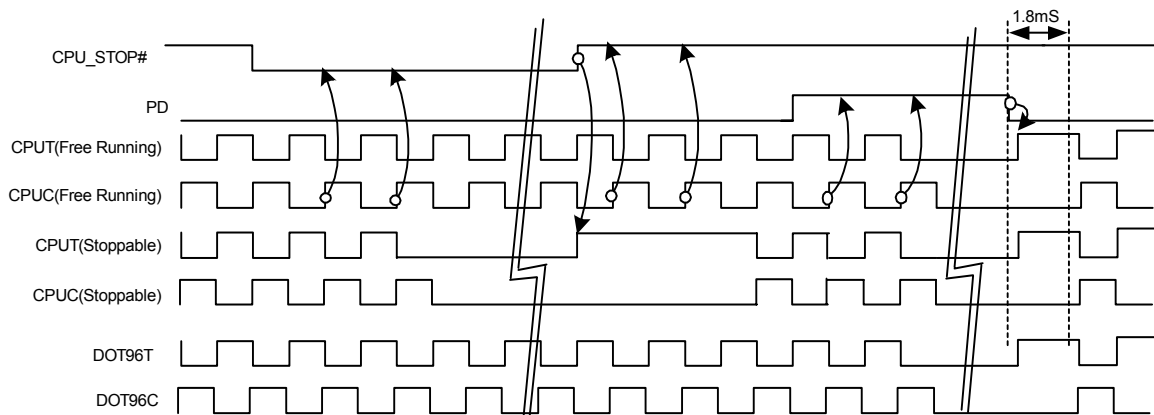
The deassertion of the CPU\_STP# signal will cause all CPU outputs that were stopped to resume normal operation in a synchronous manner. Synchronous manner meaning that no short or stretched clock pulses will be produce when the clock resumes. The maximum latency from the deassertion to active outputs is no more than two CPU clock cycles.


**Figure 5. Power-down Deassertion Timing Waveform**

**Figure 6. CPU\_STP# Assertion Waveform**

**Figure 7. CPU\_STP# Deassertion Waveform**





**Figure 8. CPU\_STOP# = Driven, CPU\_PD = Driven, DOT\_PD = Driven**

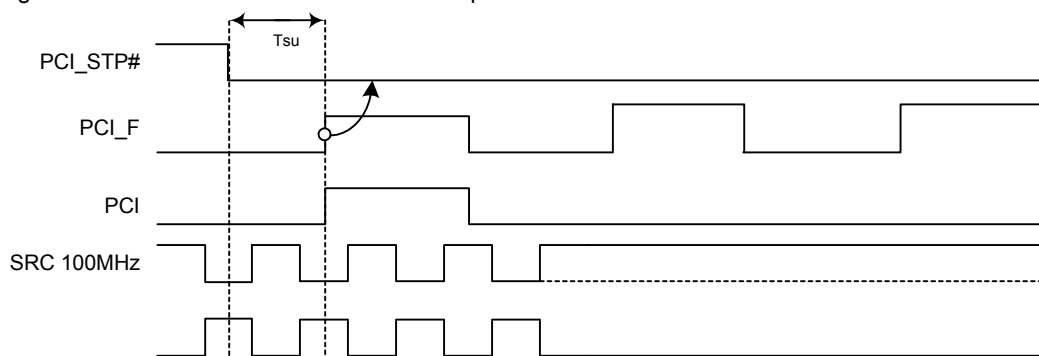


**Figure 9. CPU\_STOP# = Tri-state, CPU\_PD = Tri-state, DOT\_PD = Tri-state**

### PCI\_STOP# Assertion

The PCI\_STOP# signal is an active LOW input used for synchronous stopping and starting the PCI outputs while the rest of the clock generator continues to function. The set-up

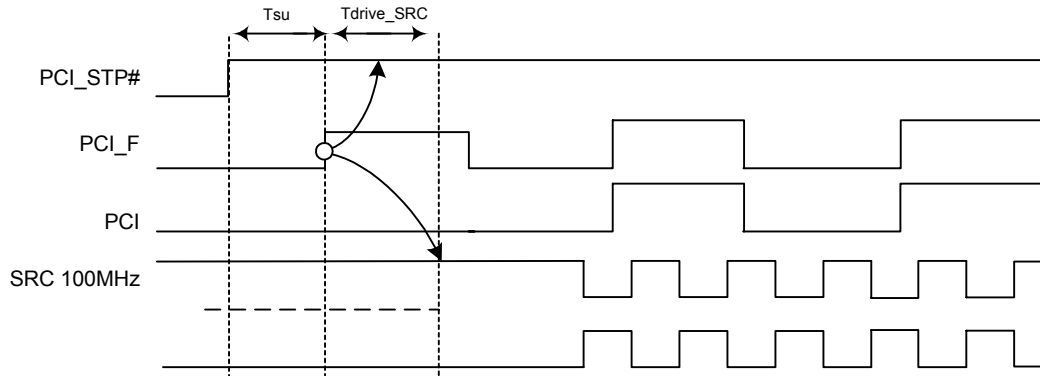
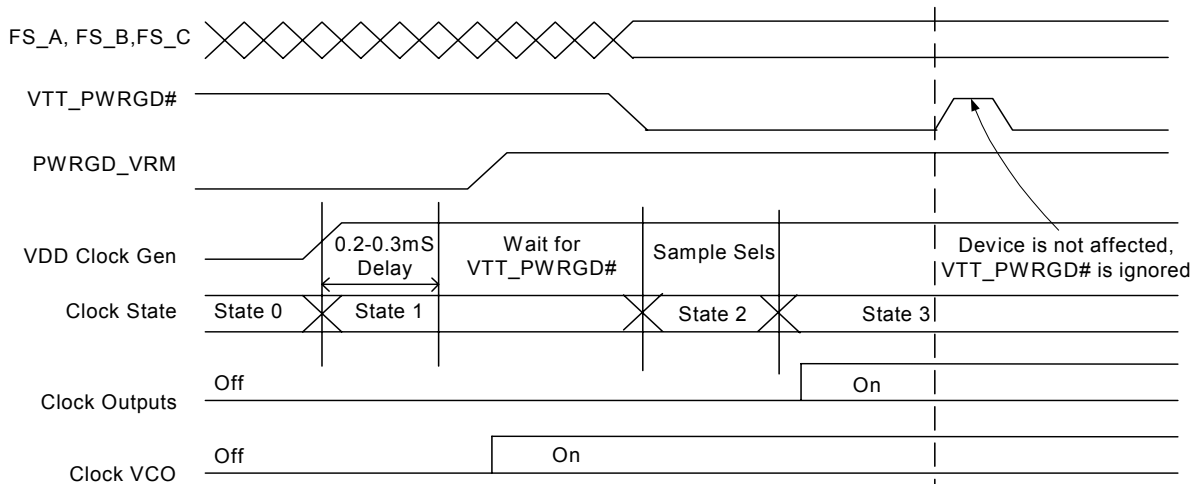
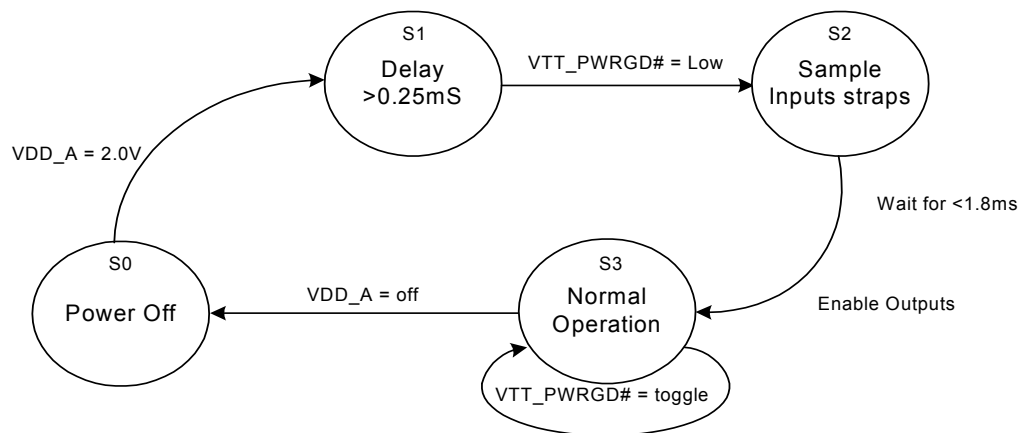
time for capturing PCI\_STOP# going LOW is 10 ns ( $t_{SU}$ ). (See Figure 10.) The PCIF clocks will not be affected by this pin if their corresponding control bit in the SMBus register is set to allow them to be free running.



**Figure 10. PCI\_STOP# Assertion Waveform**

**PCI\_STP# Deassertion**

The deassertion of the PCI\_STP# signal will cause all PCI and stoppable PCIF clocks to resume running in a synchronous manner within two PCI clock periods after PCI\_STP# transitions to a high level.


**Figure 11. PCI\_STP# Deassertion Waveform**

**Figure 12. VTT\_PWRGD# Timing Diagram**

**Figure 13. Clock Generator Power-up/Run State Diagram**

**Absolute Maximum Conditions**

Parameter	Description	Condition	Min.	Max.	Unit
V <sub>DD</sub>	Core Supply Voltage		-0.5	4.6	V
V <sub>DD_A</sub>	Analog Supply Voltage		-0.5	4.6	V
V <sub>IN</sub>	Input Voltage	Relative to V <sub>SS</sub>	-0.5	V <sub>DD</sub> + 0.5	VDC
T <sub>S</sub>	Temperature, Storage	Non-functional	-65	150	°C
T <sub>A</sub>	Temperature, Operating Ambient	Functional	0	85	°C
T <sub>J</sub>	Temperature, Junction	Functional	-	150	°C
∅ <sub>JC</sub>	Dissipation, Junction to Case	Mil-STD-883E Method 1012.1	-	20	°C/W
∅ <sub>JA</sub>	Dissipation, Junction to Ambient	JEDEC (JESD 51)	-	60	°C/W
ESD <sub>HBM</sub>	ESD Protection (Human Body Model)	MIL-STD-883, Method 3015	2000	-	V
UL-94	Flammability Rating	At 1/8 in.	V-0		
MSL	Moisture Sensitivity Level		1		

**Multiple Supplies:** The Voltage on any input or I/O pin cannot exceed the power pin during power-up. Power supply sequencing is NOT required.

**DC Electrical Specifications**

Parameter	Description	Condition	Min.	Max.	Unit
All V <sub>DD</sub> s	3.3V Operating Voltage	3.3 ± 5%	3.135	3.465	V
V <sub>IL2C</sub>	Input Low Voltage	SDATA, SCLK	-	1.0	V
V <sub>IH2C</sub>	Input High Voltage	SDATA, SCLK	2.2	-	V
V <sub>IL_FS</sub>	FS_[A,B] Input Low Voltage		V <sub>SS</sub> - 0.3	0.35	V
V <sub>IH_FS</sub>	FS_[A,B] Input High Voltage		0.7	V <sub>DD</sub> + 0.5	V
V <sub>ILFS_C</sub>	FS_C Input Low Voltage		V <sub>SS</sub> - 0.3	0.35	V
V <sub>IMFS_C</sub>	FS_C Input Middle Voltage		0.7	1.7	V
V <sub>IHFS_C</sub>	FS_C Input High Voltage		1.8	V <sub>DD</sub> + 0.5	V
V <sub>IL</sub>	3.3V Input Low Voltage		V <sub>SS</sub> - 0.3	0.8	V
V <sub>IH</sub>	3.3V Input High Voltage		2.0	V <sub>DD</sub> + 0.3	V
I <sub>IL</sub>	Input Low Leakage Current	Except internal pull-up resistors, 0 < V <sub>IN</sub> < V <sub>DD</sub>	-5	5	μA
I <sub>IH</sub>	Input High Leakage Current	Except internal pull-down resistors, 0 < V <sub>IN</sub> < V <sub>DD</sub>	-	5	μA
V <sub>OL</sub>	3.3V Output Low Voltage	I <sub>OL</sub> = 1 mA	-	0.4	V
V <sub>OH</sub>	3.3V Output High Voltage	I <sub>OH</sub> = -1 mA	2.4	-	V
I <sub>OZ</sub>	High-impedance Output Current		-10	10	μA
C <sub>IN</sub>	Input Pin Capacitance		3	5	pF
C <sub>OUT</sub>	Output Pin Capacitance		3	6	pF
L <sub>IN</sub>	Pin Inductance		-	7	nH
V <sub>XIH</sub>	Xin High Voltage		0.7V <sub>DD</sub>	V <sub>DD</sub>	V
V <sub>XIL</sub>	Xin Low Voltage		0	0.3V <sub>DD</sub>	V
I <sub>DD3.3V</sub>	Dynamic Supply Current	At max. load and freq. per Figure 15	-	TBD	mA
I <sub>PD3.3V</sub>	Power-down Supply Current	PD asserted, Outputs Driven	-	TBD	mA
I <sub>PD3.3V</sub>	Power-down Supply Current	PD asserted, Outputs Tri-state	-	TBD	mA

**AC Electrical Specifications**

Parameter	Description	Condition	Min.	Max.	Unit
<b>Crystal</b>					
T <sub>DC</sub>	XIN Duty Cycle	The device will operate reliably with input duty cycles up to 30/70 but the REF clock duty cycle will not be within specification	47.5	52.5	%
T <sub>PERIOD</sub>	XIN Period	When XIN is driven from an external clock source	69.841	71.0	ns
T <sub>R</sub> / T <sub>F</sub>	XIN Rise and Fall Times	Measured between 0.3V <sub>DD</sub> and 0.7V <sub>DD</sub>	–	10.0	ns
T <sub>CCJ</sub>	XIN Cycle to Cycle Jitter	As an average over 1-μs duration	–	500	ps
L <sub>ACC</sub>	Long-term Accuracy	Measured at crossing point V <sub>OX</sub>	–	300	ppm
<b>CPU at 0.7V</b>					
T <sub>DC</sub>	CPUT and CPUC Duty Cycle	Measured at crossing point V <sub>OX</sub>	45	55	%
T <sub>PERIOD</sub>	100-MHz CPUT and CPUC Period	Measured at crossing point V <sub>OX</sub>	9.997001	10.00300	ns
T <sub>PERIOD</sub>	133-MHz CPUT and CPUC Period	Measured at crossing point V <sub>OX</sub>	7.497751	7.502251	ns
T <sub>PERIOD</sub>	166-MHz CPUT and CPUC Period	Measured at crossing point V <sub>OX</sub>	5.998201	6.001801	ns
T <sub>PERIOD</sub>	200-MHz CPUT and CPUC Period	Measured at crossing point V <sub>OX</sub>	4.998500	5.001500	ns
T <sub>PERIODSS</sub>	100-MHz CPUT and CPUC Period, SSC	Measured at crossing point V <sub>OX</sub>	9.997001	10.05327	ns
T <sub>PERIODSS</sub>	133-MHz CPUT and CPUC Period, SSC	Measured at crossing point V <sub>OX</sub>	7.497751	7.539950	ns
T <sub>PERIODSS</sub>	166-MHz CPUT and CPUC Period, SSC	Measured at crossing point V <sub>OX</sub>	5.998201	6.031960	ns
T <sub>PERIODSS</sub>	200-MHz CPUT and CPUC Period, SSC	Measured at crossing point V <sub>OX</sub>	4.998500	5.026634	ns
T <sub>PERIODAbs</sub>	100-MHz CPUT and CPUC Absolute period	Measured at crossing point V <sub>OX</sub>	9.912001	10.08800	ns
T <sub>PERIODAbs</sub>	133-MHz CPUT and CPUC Absolute period	Measured at crossing point V <sub>OX</sub>	7.412751	7.587251	ns
T <sub>PERIODAbs</sub>	166-MHz CPUT and CPUC Absolute period	Measured at crossing point V <sub>OX</sub>	5.913201	6.086801	ns
T <sub>PERIODAbs</sub>	200-MHz CPUT and CPUC Absolute period	Measured at crossing point V <sub>OX</sub>	4.913500	5.086500	ns
T <sub>PERIODSSAbs</sub>	100-MHz CPUT and CPUC Absolute period, SSC	Measured at crossing point V <sub>OX</sub>	9.912001	10.13827	ns
T <sub>PERIODSSAbs</sub>	133-MHz CPUT and CPUC Absolute period, SSC	Measured at crossing point V <sub>OX</sub>	7.412751	7.624950	ns
T <sub>PERIODSSAbs</sub>	166-MHz CPUT and CPUC Absolute period, SSC	Measured at crossing point V <sub>OX</sub>	5.913201	6.116960	ns
T <sub>PERIODSSAbs</sub>	200-MHz CPUT and CPUC Absolute period, SSC	Measured at crossing point V <sub>OX</sub>	4.913500	5.111634	ns
T <sub>CCJ</sub>	CPUT/C Cycle to Cycle Jitter	Measured at crossing point V <sub>OX</sub>	–	80	ps
T <sub>CCJ2</sub>	CPU2_ITP Cycle to Cycle Jitter	Measured at crossing point V <sub>OX</sub>	–	80	ps
L <sub>ACC</sub>	Long-term Accuracy	Measured at crossing point V <sub>OX</sub>	–	300	ppm
T <sub>SKEW</sub>	CPU1 to CPU0 Clock Skew	Measured at crossing point V <sub>OX</sub>	–	100	ps
T <sub>R</sub> / T <sub>F</sub>	CPUT and CPUC Rise and Fall Time	Measured from V <sub>OL</sub> = 0.175 to V <sub>OH</sub> = 0.525V	175	700	ps
T <sub>RFM</sub>	Rise/Fall Matching	Determined as a fraction of 2*(T <sub>R</sub> – T <sub>F</sub> )/(T <sub>R</sub> + T <sub>F</sub> )	–	20	%
ΔT <sub>R</sub>	Rise Time Variation		–	125	ps
ΔT <sub>F</sub>	Fall Time Variation		–	125	ps
V <sub>HIGH</sub>	Voltage High	Math averages Figure 15	660	850	mV
V <sub>LOW</sub>	Voltage Low	Math averages Figure 15	–150	–	mV
V <sub>OX</sub>	Crossing Point Voltage at 0.7V Swing		250	550	mV

**AC Electrical Specifications** (continued)

Parameter	Description	Condition	Min.	Max.	Unit
V <sub>OVS</sub>	Maximum Overshoot Voltage		–	V <sub>HIGH</sub> + 0.3	V
V <sub>UDS</sub>	Minimum Undershoot Voltage		–0.3	–	V
V <sub>RB</sub>	Ring Back Voltage	See Figure 15. Measure SE	–	0.2	V
<b>SRC</b>					
T <sub>DC</sub>	SRCT and SRCC Duty Cycle	Measured at crossing point V <sub>OX</sub>	45	55	%
T <sub>PERIOD</sub>	100-MHz SRCT and SRCC Period	Measured at crossing point V <sub>OX</sub>	9.997001	10.00300	ns
T <sub>PERIODSS</sub>	100-MHz SRCT and SRCC Period, SSC	Measured at crossing point V <sub>OX</sub>	9.997001	10.05327	ns
T <sub>PERIODAbs</sub>	100-MHz SRCT and SRCC Absolute Period	Measured at crossing point V <sub>OX</sub>	9.872001	10.12800	ns
T <sub>PERIODSSAbs</sub>	100-MHz SRCT and SRCC Absolute Period, SSC	Measured at crossing point V <sub>OX</sub>	9.872001	10.17827	ns
T <sub>SKEW</sub>	Any SRCT/C to SRCT/C Clock Skew	Measured at crossing point V <sub>OX</sub>	–	250	ps
T <sub>CCJ</sub>	SRCT/C Cycle to Cycle Jitter	Measured at crossing point V <sub>OX</sub>	–	125	ps
L <sub>ACC</sub>	SRCT/C Long Term Accuracy	Measured at crossing point V <sub>OX</sub>	–	300	ppm
T <sub>R</sub> / T <sub>F</sub>	SRCT and SRCC Rise and Fall Time	Measured from V <sub>OL</sub> = 0.175 to V <sub>OH</sub> = 0.525V	175	700	ps
T <sub>RFM</sub>	Rise/Fall Matching	Determined as a fraction of 2*(T <sub>R</sub> – T <sub>F</sub> )/(T <sub>R</sub> + T <sub>F</sub> )	–	20	%
ΔT <sub>R</sub>	Rise Time Variation		–	125	ps
ΔT <sub>F</sub>	Fall Time Variation		–	125	ps
V <sub>HIGH</sub>	Voltage High	Math averages Figure 15	660	850	mV
V <sub>LOW</sub>	Voltage Low	Math averages Figure 15	–150	–	mV
V <sub>OX</sub>	Crossing Point Voltage at 0.7V Swing		250	550	mV
V <sub>OVS</sub>	Maximum Overshoot Voltage		–	V <sub>HIGH</sub> + 0.3	V
V <sub>UDS</sub>	Minimum Undershoot Voltage		–0.3	–	V
V <sub>RB</sub>	Ring Back Voltage	See Figure 15. Measure SE	–	0.2	V
<b>LCD100M_SSC</b>					
T <sub>DC</sub>	SSCT and SSCC Duty Cycle	Measured at crossing point V <sub>OX</sub>	45	55	%
T <sub>PERIOD</sub>	100-MHz SSCT and SSCC Period	Measured at crossing point V <sub>OX</sub>	9.997001	10.00300	ns
T <sub>PERIODSS</sub>	100-MHz SSCT and SSCC Period, SSC	Measured at crossing point V <sub>OX</sub>	9.997001	10.05327	ns
T <sub>PERIODAbs</sub>	100-MHz SSCT and SSCC Absolute Period	Measured at crossing point V <sub>OX</sub>	9.872001	10.12800	ns
T <sub>PERIODSSAbs</sub>	100-MHz SRCT and SRCC Absolute Period, SSC	Measured at crossing point V <sub>OX</sub>	9.872001	10.17827	ns
T <sub>PERIOD</sub>	96-MHz SSCT and SSCC Period	Measured at crossing point V <sub>OX</sub>	10.41354	10.41979	ns
T <sub>PERIODSS</sub>	96-MHz SSCT and SSCC Period, SSC	Measured at crossing point V <sub>OX</sub>	10.41354	10.47215	ns
T <sub>PERIODAbs</sub>	96-MHz SSCT and SSCC Absolute Period	Measured at crossing point V <sub>OX</sub>	10.16354	10.66979	ns
T <sub>PERIODSSAbs</sub>	96-MHz SRCT and SRCC Absolute Period, SSC	Measured at crossing point V <sub>OX</sub>	10.16354	10.72266	ns
T <sub>CCJ</sub>	SSCT/C Cycle to Cycle Jitter	Measured at crossing point V <sub>OX</sub>	–	125	ps
L <sub>ACC</sub>	SSCT/C Long Term Accuracy	Measured at crossing point V <sub>OX</sub>	–	300	ppm
T <sub>R</sub> / T <sub>F</sub>	SSCT and SSCC Rise and Fall Time	Measured from V <sub>OL</sub> = 0.175 to V <sub>OH</sub> = 0.525V	175	700	ps

**AC Electrical Specifications** (continued)

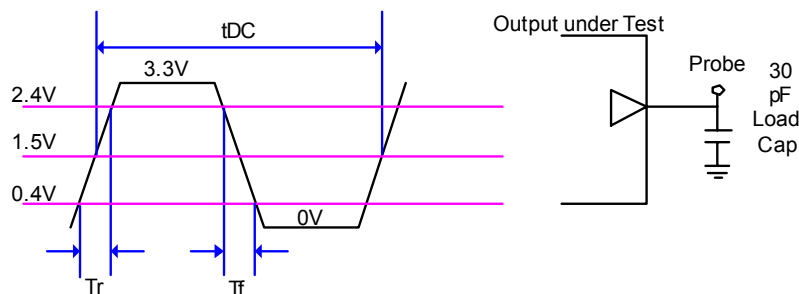
Parameter	Description	Condition	Min.	Max.	Unit
T <sub>RFM</sub>	Rise/Fall Matching	Determined as a fraction of $2*(T_R - T_F)/(T_R + T_F)$	–	20	%
ΔT <sub>R</sub>	Rise Time Variation		–	125	ps
ΔT <sub>F</sub>	Fall Time Variation		–	125	ps
V <sub>HIGH</sub>	Voltage High	Math averages <i>Figure 15</i>	660	850	mV
V <sub>LOW</sub>	Voltage Low	Math averages <i>Figure 15</i>	–150	–	mV
V <sub>OX</sub>	Crossing Point Voltage at 0.7V Swing		250	550	mV
V <sub>OVS</sub>	Maximum Overshoot Voltage		–	V <sub>HIGH</sub> + 0.3	V
V <sub>UDS</sub>	Minimum Undershoot Voltage		–0.3	–	V
V <sub>RB</sub>	Ring Back Voltage	See <i>Figure 15</i> . Measure SE	–	0.2	V
<b>PCI/PCIF</b>					
T <sub>DC</sub>	PCI Duty Cycle	Measurement at 1.5V	45	55	%
T <sub>PERIOD</sub>	Spread Disabled PCIF/PCI Period	Measurement at 1.5V	29.99100	30.00900	ns
T <sub>PERIODSS</sub>	Spread Enabled PCIF/PCI Period, SSC	Measurement at 1.5V	29.9910	30.15980	ns
T <sub>PERIODAbs</sub>	Spread Disabled PCIF/PCI Period	Measurement at 1.5V	29.49100	30.50900	ns
T <sub>PERIODSSAbs</sub>	Spread Enabled PCIF/PCI Period, SSC	Measurement at 1.5V	29.49100	30.65980	ns
T <sub>HIGH</sub>	PCIF and PCI high time	Measurement at 2.4V	12.0	–	ns
T <sub>LOW</sub>	PCIF and PCI low time	Measurement at 0.4V	12.0	–	ns
T <sub>R</sub> / T <sub>F</sub>	PCIF/PCI rising and falling Edge Rate	Measured between 0.8V and 2.0V	1.0	4.0	V/ns
T <sub>SKEW</sub>	Any PCI clock to Any PCI clock Skew	Measurement at 1.5V	–	500	ps
T <sub>CCJ</sub>	PCIF and PCI Cycle to Cycle Jitter	Measurement at 1.5V	–	500	ps
L <sub>ACC</sub>	PCIF/PCI Long Term Accuracy	Measured at crossing point V <sub>OX</sub>	–	300	ppm
<b>DOT</b>					
T <sub>DC</sub>	DOT96T and DOT96C Duty Cycle	Measured at crossing point V <sub>OX</sub>	45	55	%
T <sub>PERIOD</sub>	DOT96T and DOT96C Period	Measured at crossing point V <sub>OX</sub>	10.41354	10.41979	ns
T <sub>PERIODAbs</sub>	DOT96T and DOT96C Absolute Period	Measured at crossing point V <sub>OX</sub>	10.16354	10.66979	ns
T <sub>CCJ</sub>	DOT96T/C Cycle to Cycle Jitter	Measured at crossing point V <sub>OX</sub>	–	250	ps
L <sub>ACC</sub>	DOT96T/C Long Term Accuracy	Measured at crossing point V <sub>OX</sub>	–	300	ppm
T <sub>R</sub> / T <sub>F</sub>	DOT96T and DOT96C Rise and Fall Time	Measured from V <sub>OL</sub> = 0.175 to V <sub>OH</sub> = 0.525V	175	700	ps
T <sub>RFM</sub>	Rise/Fall Matching	Determined as a fraction of $2*(T_R - T_F)/(T_R + T_F)$	–	20	%
ΔT <sub>R</sub>	Rise Time Variation		–	125	ps
ΔT <sub>F</sub>	Fall Time Variation		–	125	ps
V <sub>HIGH</sub>	Voltage High	Math averages <i>Figure 15</i>	660	850	mV
V <sub>LOW</sub>	Voltage Low	Math averages <i>Figure 15</i>	–150	–	mV
V <sub>OX</sub>	Crossing Point Voltage at 0.7V Swing		250	550	mV
V <sub>OVS</sub>	Maximum Overshoot Voltage		–	V <sub>HIGH</sub> + 0.3	V
V <sub>UDS</sub>	Minimum Undershoot Voltage		–0.3	–	V
V <sub>RB</sub>	Ring Back Voltage	See <i>Figure 15</i> . Measure SE	–	0.2	V
<b>48_M</b>					
T <sub>DC</sub>	Duty Cycle	Measurement at 1.5V	45	55	%
T <sub>PERIOD</sub>	Period	Measurement at 1.5V	20.83125	20.83542	ns

**AC Electrical Specifications** (continued)

Parameter	Description	Condition	Min.	Max.	Unit
$T_{PERIODAbs}$	Absolute Period	Measurement at 1.5V	20.48125	21.18542	ns
$T_{HIGH}$	48_M High time	Measurement at 2.4V	8.094	10.036	ns
$T_{LOW}$	48_M Low time	Measurement at 0.4V	7.694	9.836	ns
$T_R / T_F$	Rising and Falling Edge Rate	Measured between 0.8V and 2.0V	1.0	2.0	V/ns
$T_{CCJ}$	Cycle to Cycle Jitter	Measurement at 1.5V	–	350	ps
$L_{ACC}$	48M Long Term Accuracy	Measured at crossing point $V_{OX}$	–	100	ppm
<b>27_M</b>					
$T_{DC}$	Duty Cycle	Measurement at 1.5V	45	55	%
$T_{PERIOD}$	Spread Disabled 27M Period	Measurement at 1.5V	27.000	27.0547	ns
	Spread Enabled 27M Period	Measurement at 1.5V	27.000	27.0547	
$T_{HIGH}$	27_M High time	Measurement at 2.0V	10.5	–	ns
$T_{LOW}$	27_M Low time	Measurement at 0.8V	10.5	–	ns
$T_R / T_F$	Rising and Falling Edge Rate	Measured between 0.8V and 2.0V	1.0	4.0	V/ns
$T_{CCJ}$	Cycle to Cycle Jitter	Measurement at 1.5V	–	500	ps
$L_{ACC}$	27_M Long Term Accuracy	Measured at crossing point $V_{OX}$	–	50	ppm
<b>REF</b>					
$T_{DC}$	REF Duty Cycle	Measurement at 1.5V	45	55	%
$T_{PERIOD}$	REF Period	Measurement at 1.5V	69.8203	69.8622	ns
$T_{PERIODAbs}$	REF Absolute Period	Measurement at 1.5V	68.82033	70.86224	ns
$T_R / T_F$	REF Rising and Falling Edge Rate	Measured between 0.8V and 2.0V	1.0	4.0	V/ns
$T_{SKEW}$	REF Clock to REF Clock	Measurement at 1.5V	–	500	ps
$T_{CCJ}$	REF Cycle to Cycle Jitter	Measurement at 1.5V	–	1000	ps
$L_{ACC}$	Long Term Accuracy	Measurement at 1.5V	–	300	ppm
<b>ENABLE/DISABLE and SET-UP</b>					
$T_{STABLE}$	Clock Stabilization from Power-up		–	1.8	ms
$T_{SS}$	Stopclock Set-up Time		10.0	–	ns
$T_{SH}$	Stopclock Hold Time		0	–	ns

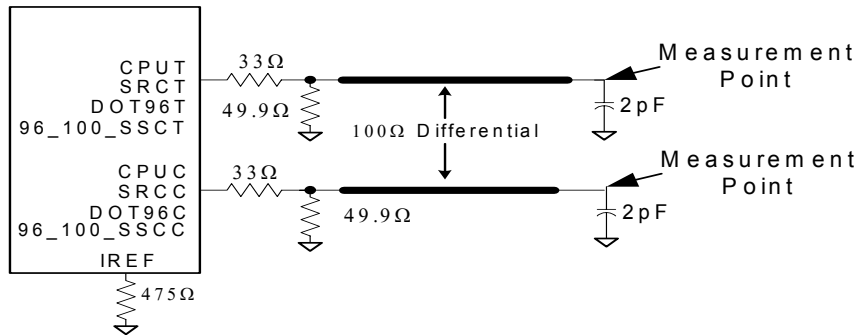
**Test and Measurement Set-up**
**For PCI Single-ended Signals and Reference**

The following diagram shows single-ended PCI output signals.

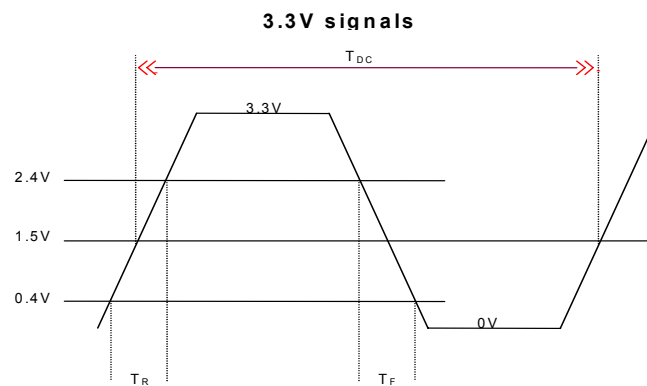


**Figure 14. Single-ended PCI Lumped Load Configuration**

The following diagram shows the test load configuration for the differential CPU and SRC outputs.



**Figure 15. 0.7V Differential Load Configuration**



**Figure 16. Single-ended Output Signals (for AC Parameters Measurement)**

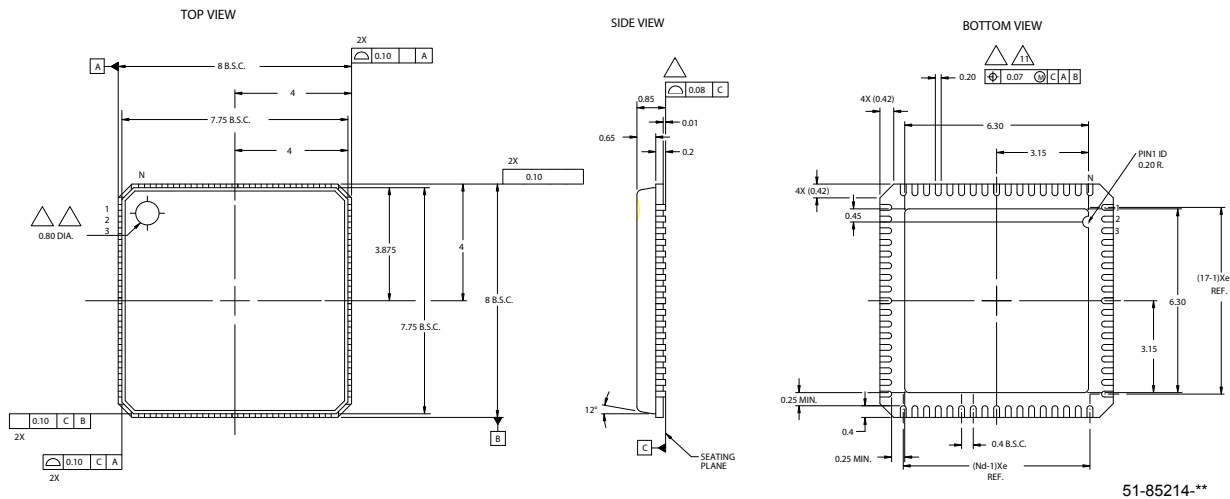
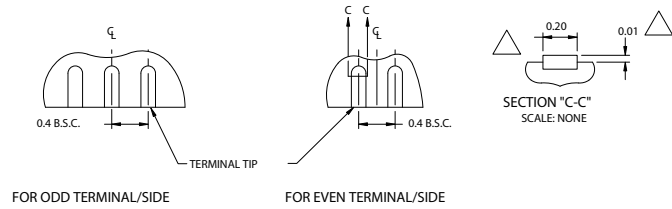
### Ordering Information

Part Number	Package Type	Product Flow
<b>Lead-free</b>		
CY28445LFXC-5	68-pin QFN	Commercial
CY28445LFXC-5T	68-pin QFN - Tape and Reel	Commercial



**Package Diagram**
**68-Lead QFN 8x 8 mm (Punch Version) LF68A**
**NOTES:**

1. DIE THICKNESS ALLOWABLE IS 0.305mm MAXIMUM (0.12 INCHES MAXIMUM)
2. DIMENSIONING & TOLERANCES CONFORM TO ASME Y14.5M - 1994.
3. N IS THE NUMBER OF TERMINALS.  
Nd IS THE NUMBER OF TERMINALS IN X-DIRECTION &  
Ne IS THE NUMBER OF TERMINALS IN Y-DIRECTION.
4. DIMENSION b APPLIES TO PLATED TERMINAL AND IS MEASURED BETWEEN 0.20 AND 0.25mm FROM TERMINAL TIP.
5. THE PIN #1 IDENTIFIER MUST BE EXISTED ON THE TOP SURFACE OF THE PACKAGE BY USING INDENTATION MARK OR OTHER FEATURE OF PACKAGE BODY.
6. EXACT SHAPE AND SIZE OF THIS FEATURE IS OPTIONAL.
7. ALL DIMENSIONS ARE IN MILLIMETERS.
8. PACKAGE WARPAGE MAX 0.08mm.
9. APPLIED FOR EXPOSED PAD AND TERMINALS.  
EXCLUDE EMBEDDING PART OF EXPOSED PAD FROM MEASURING.
10. APPLIED ONLY FOR TERMINALS.
11. FOR 0.40 mm LEAD PITCH, THE LEAD POSITION TOLERANCE MUST BE 0.07 AT THE ACTUAL MEAN VALUE OF BODY SIZE.



Purchase of I<sup>2</sup>C components from Cypress or one of its sublicensed Associated Companies conveys a license under the Philips I<sup>2</sup>C Patent Rights to use these components in an I<sup>2</sup>C system, provided that the system conforms to the I<sup>2</sup>C Standard Specification as defined by Philips. Intel and Pentium are registered trademarks of Intel Corporation. All product and company names mentioned in this document are the trademarks of their respective holders.



**Document History Page**

<b>Document Title: CY28445-5 Clock Generator for Intel® Calistoga Chipset</b> <b>Document Number: 38-07739</b>				
<b>REV.</b>	<b>ECN NO.</b>	<b>Issue Date</b>	<b>Orig. of Change</b>	<b>Description of Change</b>
**	332335	See ECN	RGL	New data sheet