

8 7 6 5 4 3 2 1

- 1. ALL RESISTANCE VALUES ARE IN OHMS, 0.1 WATT +/- 5%.
- 2. ALL CAPACITANCE VALUES ARE IN MICROFARADS.
- 3. ALL CRYSTALS & OSCILLATOR VALUES ARE IN HERTZ.

DOH-NATIONAL

Making DOH-SPRINT have less parts
DVT:10/12/2007

REV	ZONE	ECN	DESCRIPTION OF CHANGE	CK APPD	ENG APPD
?		?	?	DATE	DATE

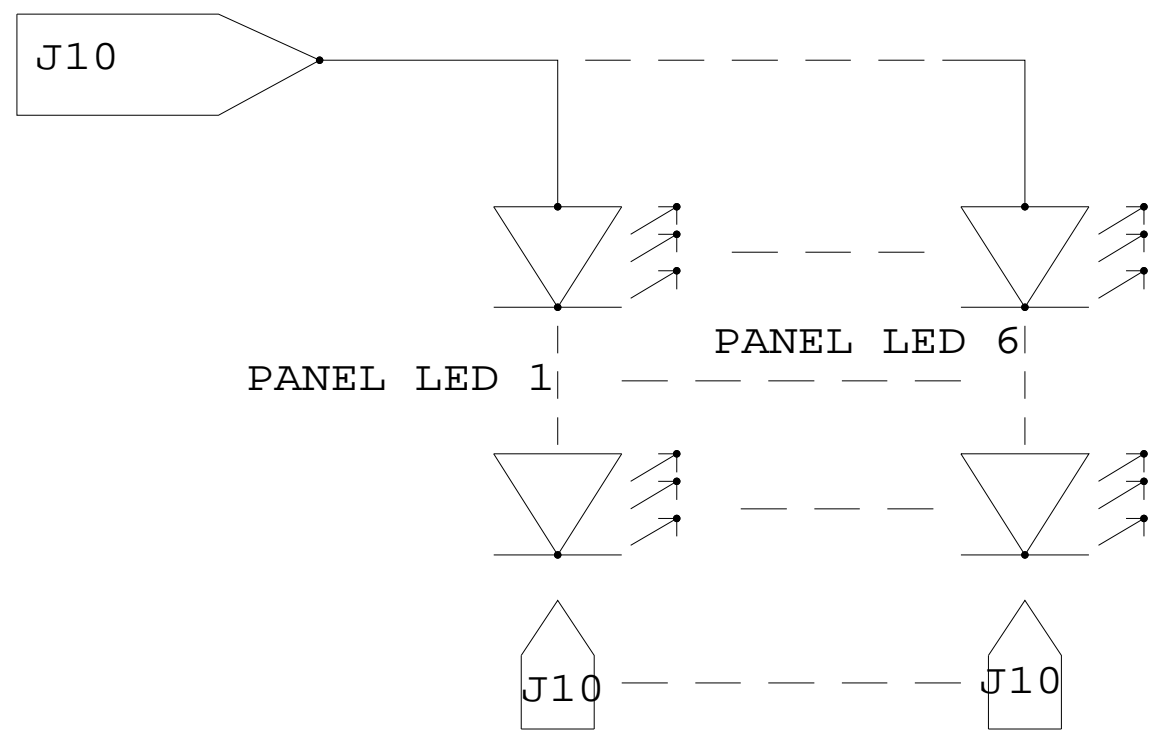
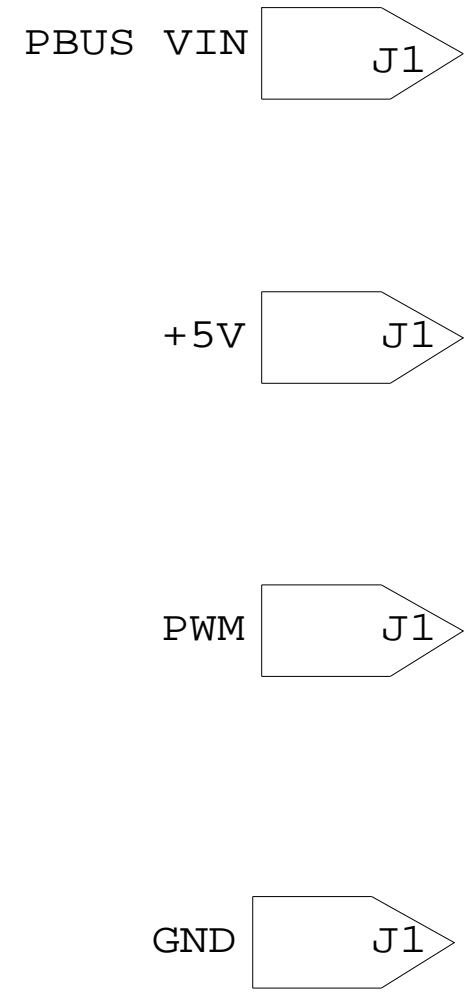

PART NUMBER	QTY	DESCRIPTION	REFERENCE DES	CRITICAL	BOM OPTION
051-7482	1	SCHEM, LED, M87-M88	SCH1	CRITICAL	
820-2297	1	PCBF, LED, M87-M88	PCB1	CRITICAL	
000-0041	1	PLACEHOLDER FOR EEE/CCC INFO	[EEE:Z3E]	CRITICAL	

DIMENSIONS ARE IN MILLIMETERS		METRIC		APPLE INC.	
XX : _____	_____	DRAPPER	DESIGN CR	NOTICE OF PROPRIETARY PROPERTY THE INFORMATION CONTAINED HEREIN IS THE PROPRIETARY PROPERTY OF APPLE COMPUTER, INC. THE POSSESSOR AGREES TO THE FOLLOWING: I TO MAINTAIN THE DOCUMENT IN CONFIDENCE II NOT TO REPRODUCE OR COPY IT III NOT TO REVEAL OR PUBLISH IN WHOLE OR PART	
X.XX : _____	_____	ENG APPD	MFG APPD		
X.XXX : _____	_____	QA APPD	DESIGNER		
ANGLES : _____	_____	RELEASE	SCALE		
DO NOT SCALE DRAWING		NONE		TITLE	
THIRD ANGLE PROJECTION		MATERIAL/FINISH NOTED AS APPLICABLE		SIZE D	DRAWING NUMBER
				051-7482	REV. 3.4.0
				SHT 1 OF 3	

8 7 6 5 4 3 2 1

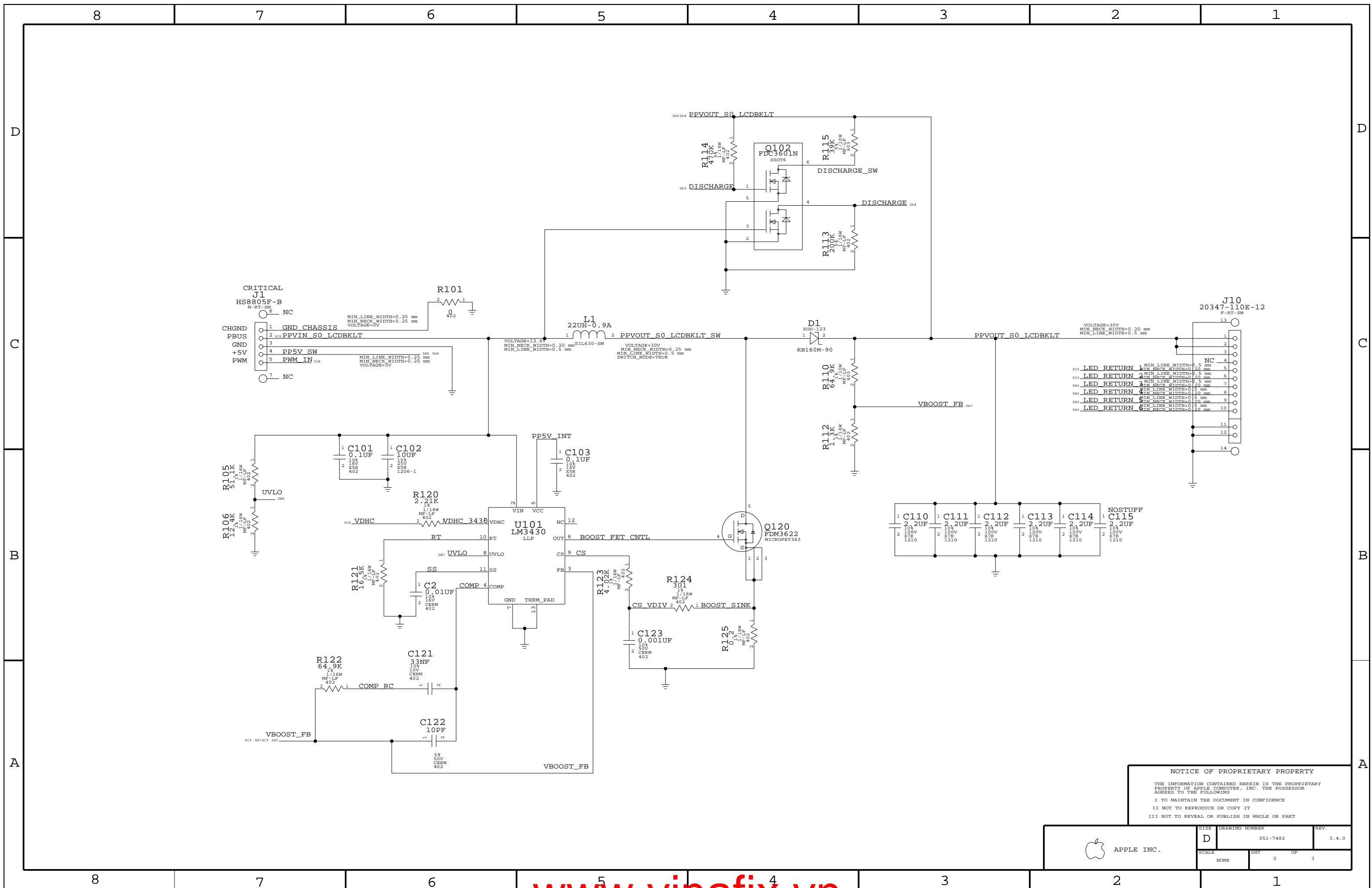

NOTICE OF PROPRIETARY PROPERTY
 THE INFORMATION CONTAINED HEREIN IS THE PROPRIETARY PROPERTY OF APPLE COMPUTER, INC. THE POSSESSOR AGREES TO THE FOLLOWING
 I TO MAINTAIN THE DOCUMENT IN CONFIDENCE
 II NOT TO REPRODUCE OR COPY IT
 III NOT TO REVEAL OR PUBLISH IN WHOLE OR PART

APPLE INC.	SIZE	DRAWING NUMBER	REV.
	D	051-7482	3.4.0
SCALE	SHT		OF
NONE	2		3

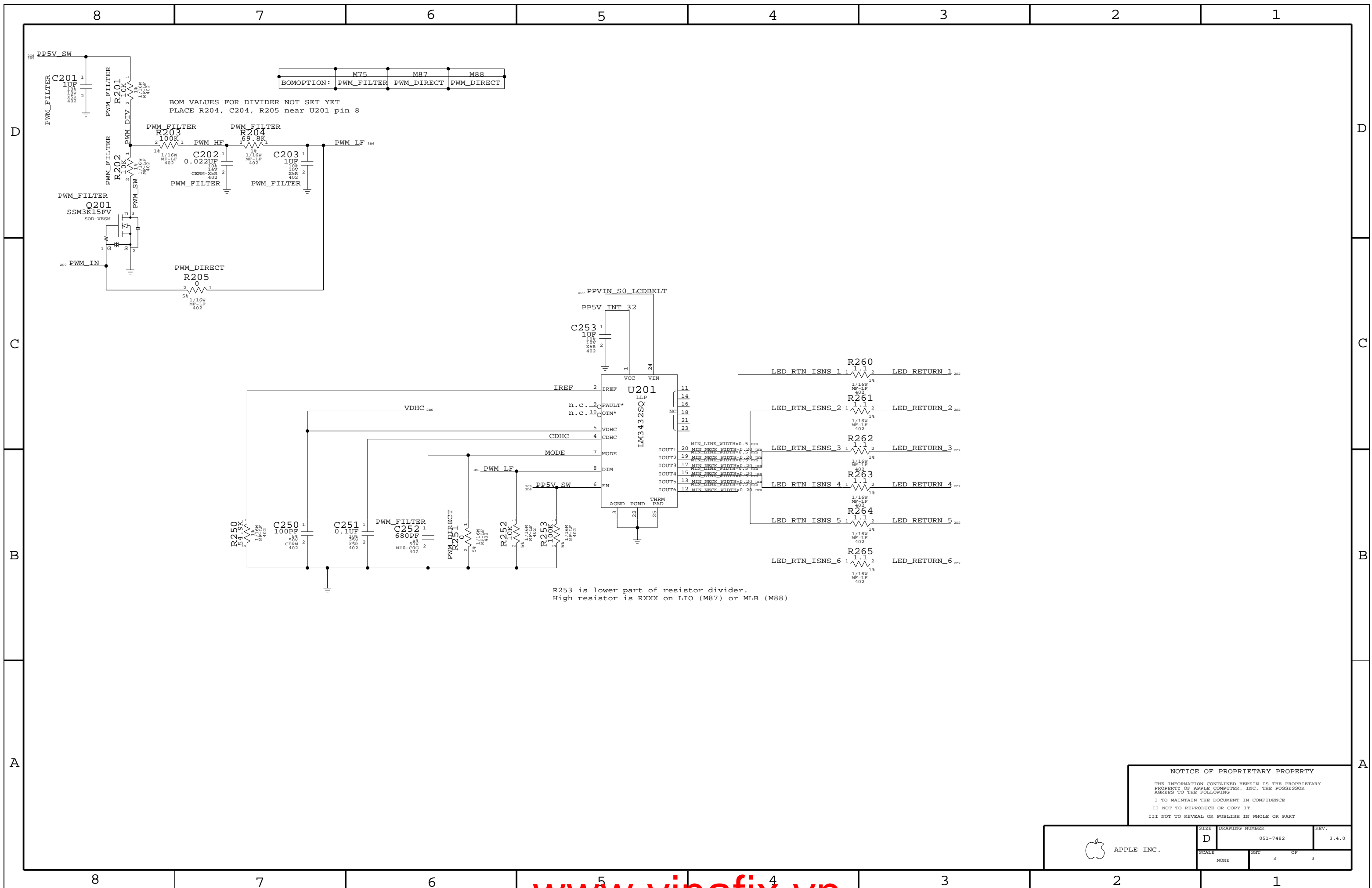

BOM VALUES FOR DIVIDER NOT SET YET
PLACE R204, C204, R205 near U201 pin 8

R253 is lower part of resistor divider.
High resistor is RXXX on LIO (M87) or MLB (M88)

NOTICE OF PROPRIETARY PROPERTY
THE INFORMATION CONTAINED HEREIN IS THE PROPRIETARY PROPERTY OF APPLE COMPUTER, INC. THE POSSESSOR AGREES TO THE FOLLOWING
I TO MAINTAIN THE DOCUMENT IN CONFIDENCE
II NOT TO REPRODUCE OR COPY IT
III NOT TO REVEAL OR PUBLISH IN WHOLE OR PART

APPLE INC.	SIZE	DRAWING NUMBER	REV.
	D	051-7482	3.4.0
SCALE	SHT	OF	
NONE	3	3	