

8

7

6

5

4

3

2

1

- 1. ALL RESISTANCE VALUES ARE IN OHMS, 0.1 WATT +/- 5%.
- 2. ALL CAPACITANCE VALUES ARE IN MICROFARADS.
- 3. ALL CRYSTALS & OSCILLATOR VALUES ARE IN HERTZ.

REV	ZONE	ECN	DESCRIPTION OF CHANGE	CK APPD DATE	ENG APPD DATE
				?	?

SCHEM, BANDCAMP, M75 EVT

01/18/06

PDF PAGE	CSA PAGE	CONTENTS	SYNC MASTER	DATE
1	1	Table of Contents		
2	2	Block Diagram		
3	4	BOM Configuration	(Master)	(Master)
4	9	Aliases	(Master)	(Master)
5	34	PCI-E MiniCard Connector	(Master)	(Master)
6	35	ExpressCard Connector	(Master)	(Master)
7	36	MLB I/O Board Connector	(Master)	(Master)
8	46	Left USB Port	(Master)	(Master)
9	56	Current & Thermal Sensors	(Master)	(Master)
10	62	AUDIO:CODEC	LENGO_M75_AUDIO	01/17/2007
11	65	AUDIO: HEADPHONE AMP	LENGO_M75_AUDIO	01/17/2007
12	66	AUDIO:SPEAKER AMP	LENGO_M75_AUDIO	01/17/2007
13	67	AUDIO: JACKS	LENGO_M75_AUDIO	01/17/2007
14	68	AUDIO: JACK TRANSLATORS	LENGO_M75_AUDIO	01/17/2007
15	69	DC-In & Battery Connectors	(Master)	(Master)
16	76	5V/3.3V SUPPLY	<MASTER>	<MASTER>
17	79	PBus Supply & Batt. Charger	(Master)	(Master)
18	90	Inverter Connector	SPLIT_INVERTER	12/06/2006
19	98	Inverter Support	SPLIT_INVERTER	01/17/2007
20	99	Inverter Control IC	SPLIT_INVERTER	01/17/2007

PART#	QTY	DESCRIPTION	REFERENCE DESIGNATOR(S)	CRITICAL	BOM OPTION
051-7226	1	SCHEM, BANDCAMP, M75	SCH1	CRITICAL	
820-2102	1	PCBF, BANDCAMP, M75	PCB1	CRITICAL	

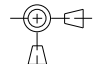
DIMENSIONS ARE IN MILLIMETERS		METRIC		 Apple Computer Inc.	
XX :	_____	DRAPTER	/	DESIGN CK	/
X.XX :	_____	ENG APPD	/	MFG APPD	/
X.XXX :	_____	QA APPD	/	DESIGNER	/
ANGLES :	_____	RELEASE	/	SCALE	NONE
DO NOT SCALE DRAWING		MATERIAL/FINISH NOTED AS APPLICABLE		SIZE	D
 THIRD ANGLE PROJECTION		DRAWING NUMBER		051-7226	REV. 5.0.0
				SHT 1 OF 20	

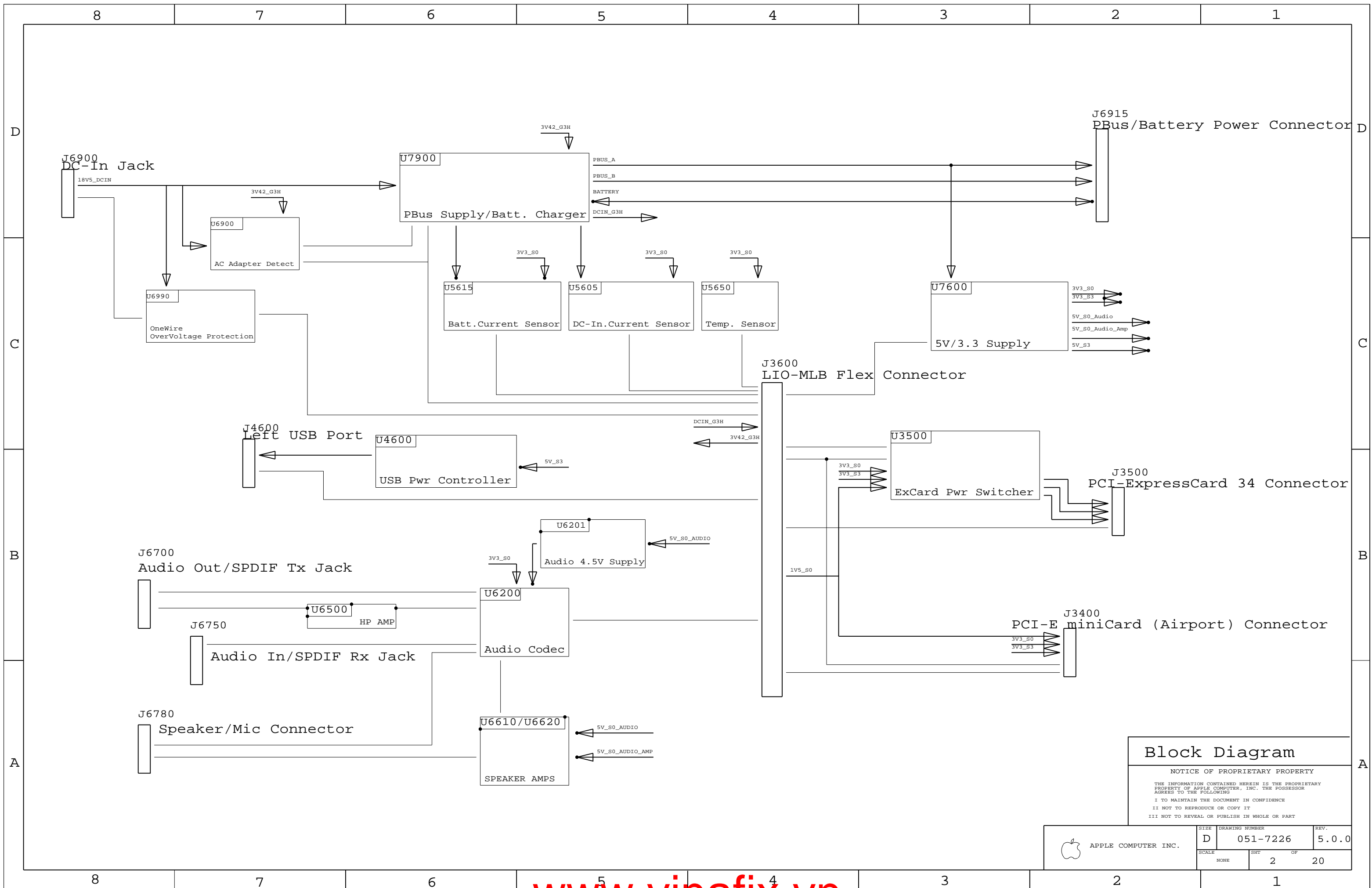

Block Diagram

NOTICE OF PROPRIETARY PROPERTY
 THE INFORMATION CONTAINED HEREIN IS THE PROPRIETARY PROPERTY OF APPLE COMPUTER, INC. THE POSSESSOR AGREES TO THE FOLLOWING
 I TO MAINTAIN THE DOCUMENT IN CONFIDENCE
 II NOT TO REPRODUCE OR COPY IT
 III NOT TO REVEAL OR PUBLISH IN WHOLE OR PART

APPLE COMPUTER INC.	SIZE	DRAWING NUMBER	REV.
	D	051-7226	5.0.0
SCALE	SHT	OF	
NONE	2	20	

8

7

6

5

4

3

2

1

BOM NUMBER	BOM NAME	BOM OPTIONS
630-7933	PCBA, BANDCAMP, M75	ALTERNATE, COMMON, M75_COMMON, INV_BYPASS, X5F
630-8087	PCBA, BAGOFINFINITE, M75	ALTERNATE, COMMON, M75_COMMON, INV_BYPASS, XPV

BOM GROUP	BOM OPTIONS
M75_COMMON	ISL6257H

Bar Code Label / EEE #'s

PART NUMBER	QTY	DESCRIPTION	REFERENCE DES	CRITICAL	BOM OPTION
000-0041	1	PLACEHOLDER FOR EEE/CCC INFO	[EEE:X5F]	CRITICAL	X5F
000-0041	1	PLACEHOLDER FOR EEE/CCC INFO	[EEE:XPV]	CRITICAL	XPV

Alternate Parts

PART NUMBER	ALTERNATE FOR PART NUMBER	BOM OPTION	REF DES	COMMENTS:
376S0448	376S0445		ALL	S17806ADN for FSM6296
128S0081	128S0061		ALL	150uF, 6.3V, 25MOHM, C2
128S0093	128S0092		ALL	33UF, 16V, 45MOHM, D2E

D

D

C

C

B

B

A

A

BOM Configuration	
SYNC_MASTER=(Master)	SYNC_DATE=(Master)
NOTICE OF PROPRIETARY PROPERTY	
THE INFORMATION CONTAINED HEREIN IS THE PROPRIETARY PROPERTY OF APPLE COMPUTER, INC. THE POSSESSOR AGREES TO THE FOLLOWING	
I TO MAINTAIN THE DOCUMENT IN CONFIDENCE	
II NOT TO REPRODUCE OR COPY IT	
III NOT TO REVEAL OR PUBLISH IN WHOLE OR PART	

 APPLE COMPUTER INC.	SIZE	DRAWING NUMBER	REV.
	D	051-7226	5.0.0
SCALE	SHT OF		
NONE	3 OF		20

8

7

6

5

4

3

2

1

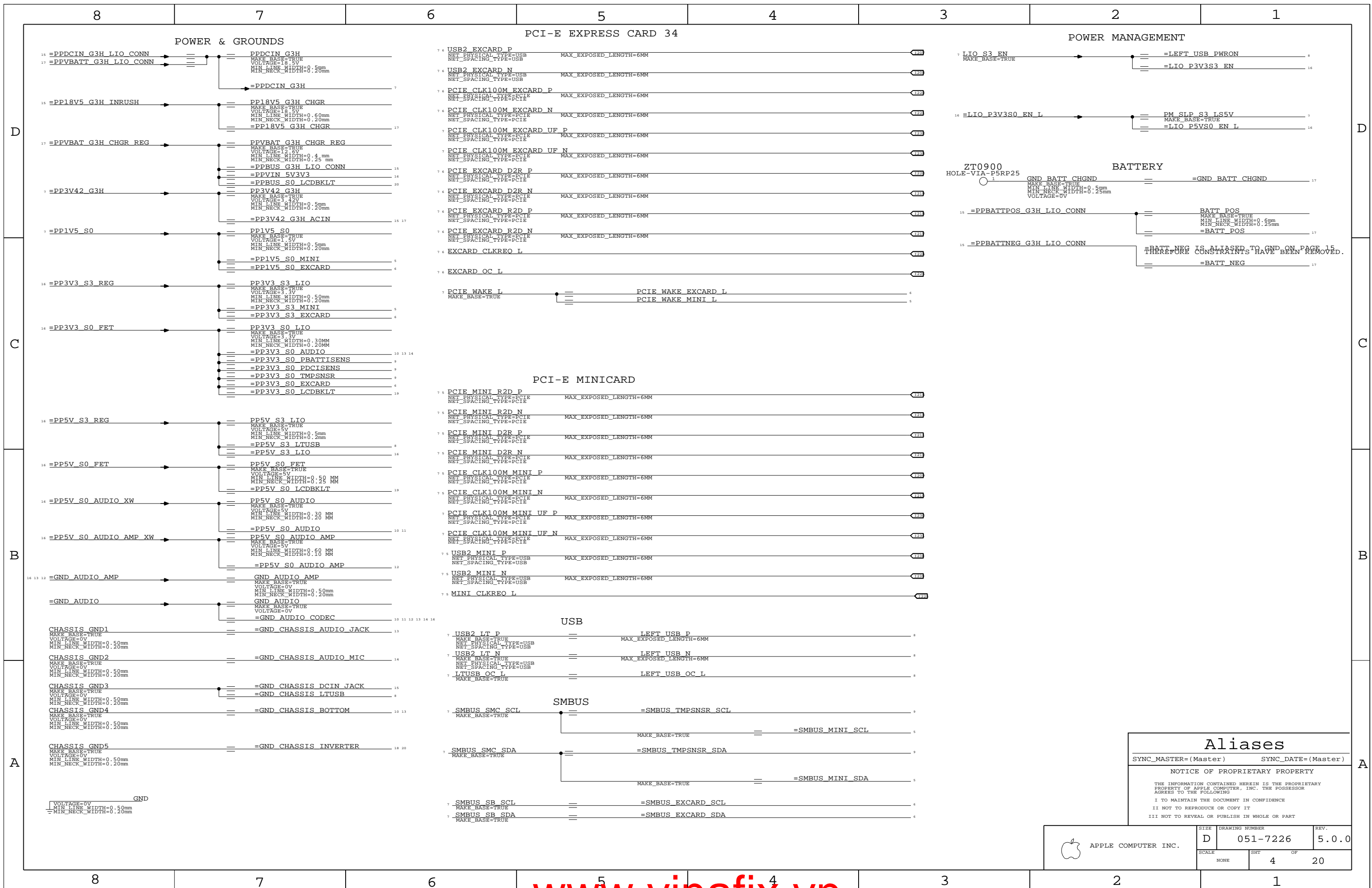

Aliases		
SYNC_MASTER=(Master)	SYNC_DATE=(Master)	
NOTICE OF PROPRIETARY PROPERTY		
THE INFORMATION CONTAINED HEREIN IS THE PROPRIETARY PROPERTY OF APPLE COMPUTER, INC. THE POSSESSOR AGREES TO THE FOLLOWING		
I TO MAINTAIN THE DOCUMENT IN CONFIDENCE		
II NOT TO REPRODUCE OR COPY IT		
III NOT TO REVEAL OR PUBLISH IN WHOLE OR PART		

APPLE COMPUTER INC.	SIZE	DRAWING NUMBER	REV.
	D	051-7226	5.0.0
SCALE	SHT	OF	
NONE	4	20	

PCI-EXPRESS MINI CARD CONNECTOR

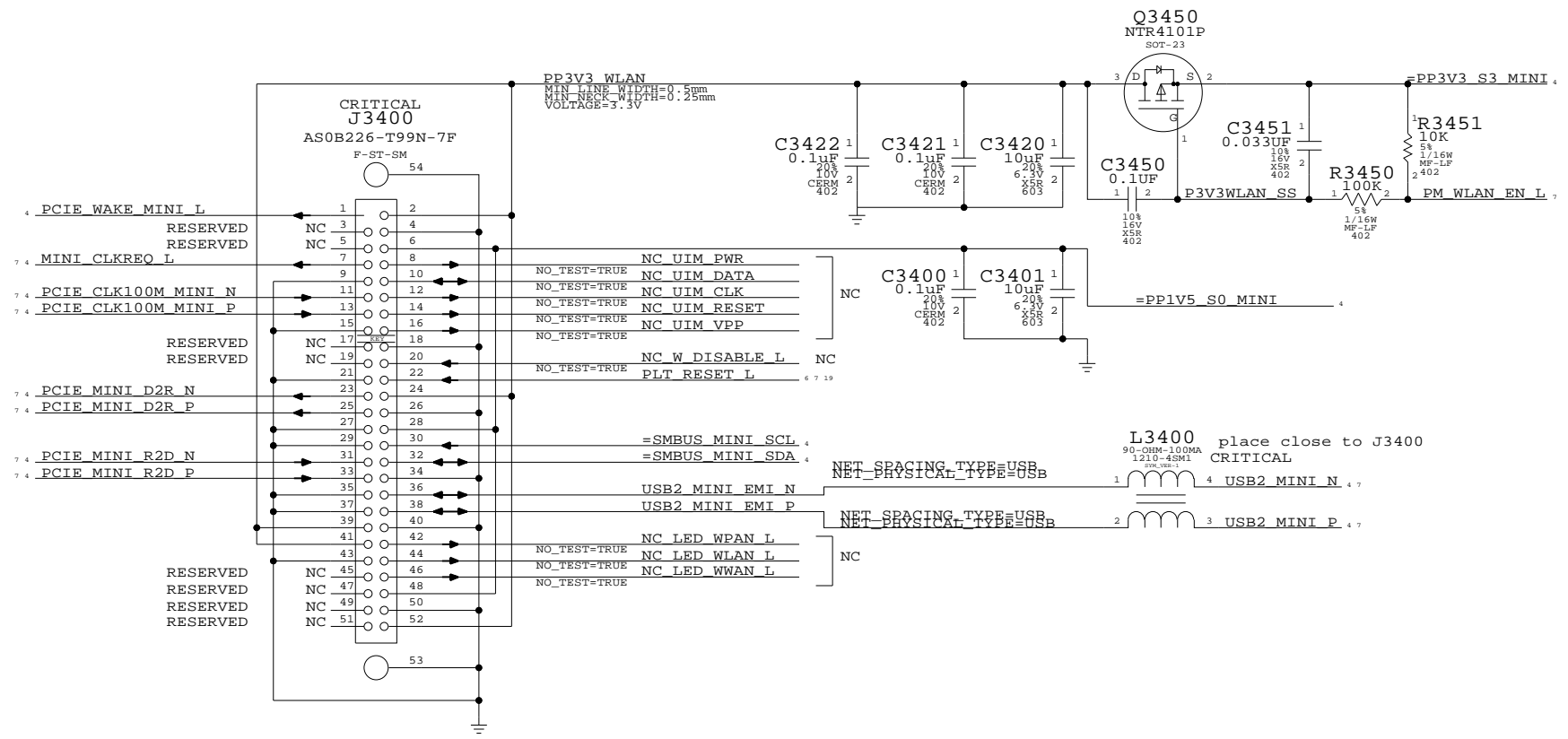

PCI-E MiniCard Connector
 SYNC_MASTER=(Master) SYNC_DATE=(Master)
NOTICE OF PROPRIETARY PROPERTY
 THE INFORMATION CONTAINED HEREIN IS THE PROPRIETARY PROPERTY OF APPLE COMPUTER, INC. THE POSSESSOR AGREES TO THE FOLLOWING
 I TO MAINTAIN THE DOCUMENT IN CONFIDENCE
 II NOT TO REPRODUCE OR COPY IT
 III NOT TO REVEAL OR PUBLISH IN WHOLE OR PART

APPLE COMPUTER INC.	SIZE	DRAWING NUMBER	REV.
	D	051-7226	5.0.0
SCALE	SHT OF		
NONE	5 OF		20

EXPRESSCARD/34 TOP MOUNT CONNECTOR

CARD CAGE CONNECTOR
CRITICAL
J3500
237-5300703903-2
P-RT-SM

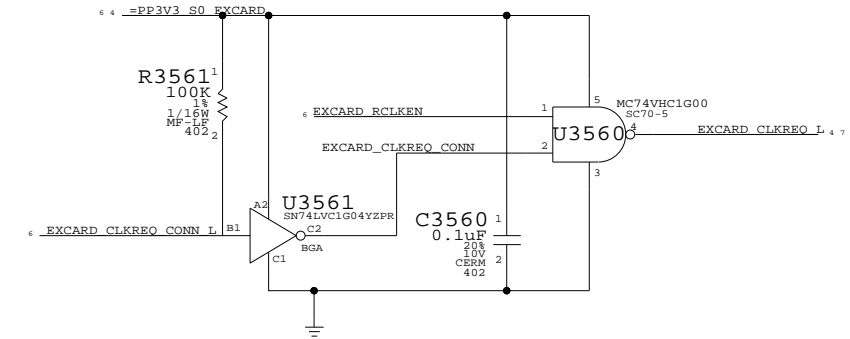
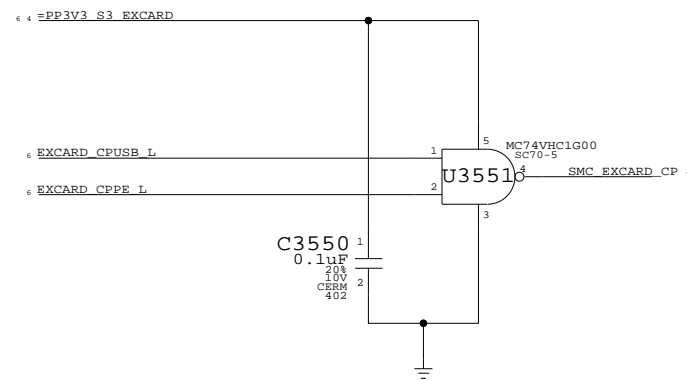
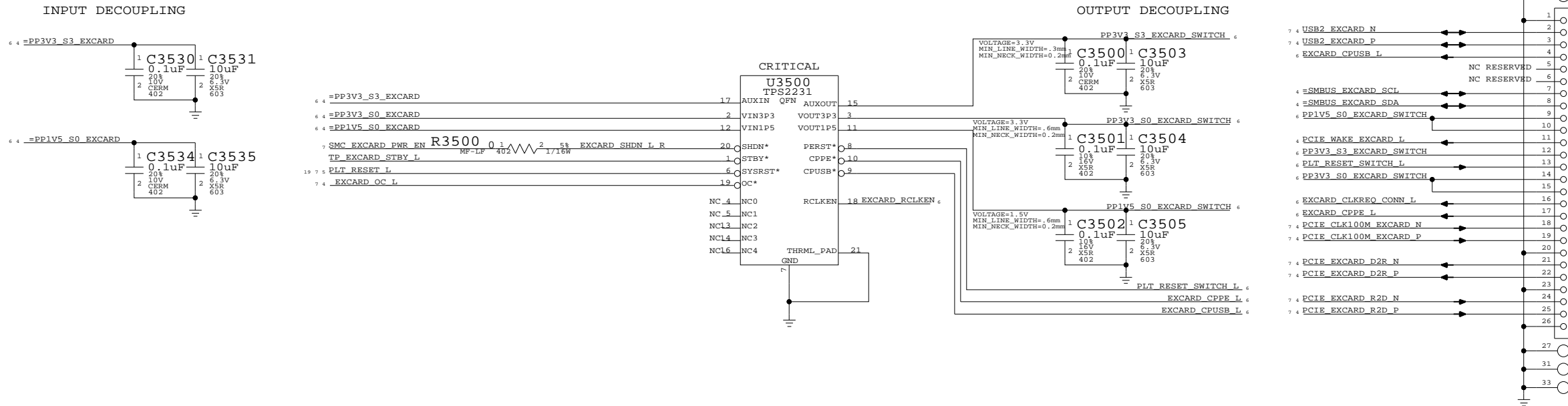

ExpressCard Connector

SYNC_MASTER=(Master) SYNC_DATE=(Master)

NOTICE OF PROPRIETARY PROPERTY

THE INFORMATION CONTAINED HEREIN IS THE PROPRIETARY PROPERTY OF APPLE COMPUTER, INC. THE POSSESSOR AGREES TO THE FOLLOWING

I TO MAINTAIN THE DOCUMENT IN CONFIDENCE

II NOT TO REPRODUCE OR COPY IT

III NOT TO REVEAL OR PUBLISH IN WHOLE OR PART

APPLE COMPUTER INC.	SIZE	DRAWING NUMBER	REV.
	D	051-7226	5.0.0
SCALE	SHT OF		
NONE	6 OF		20

Left I/O Board Connector

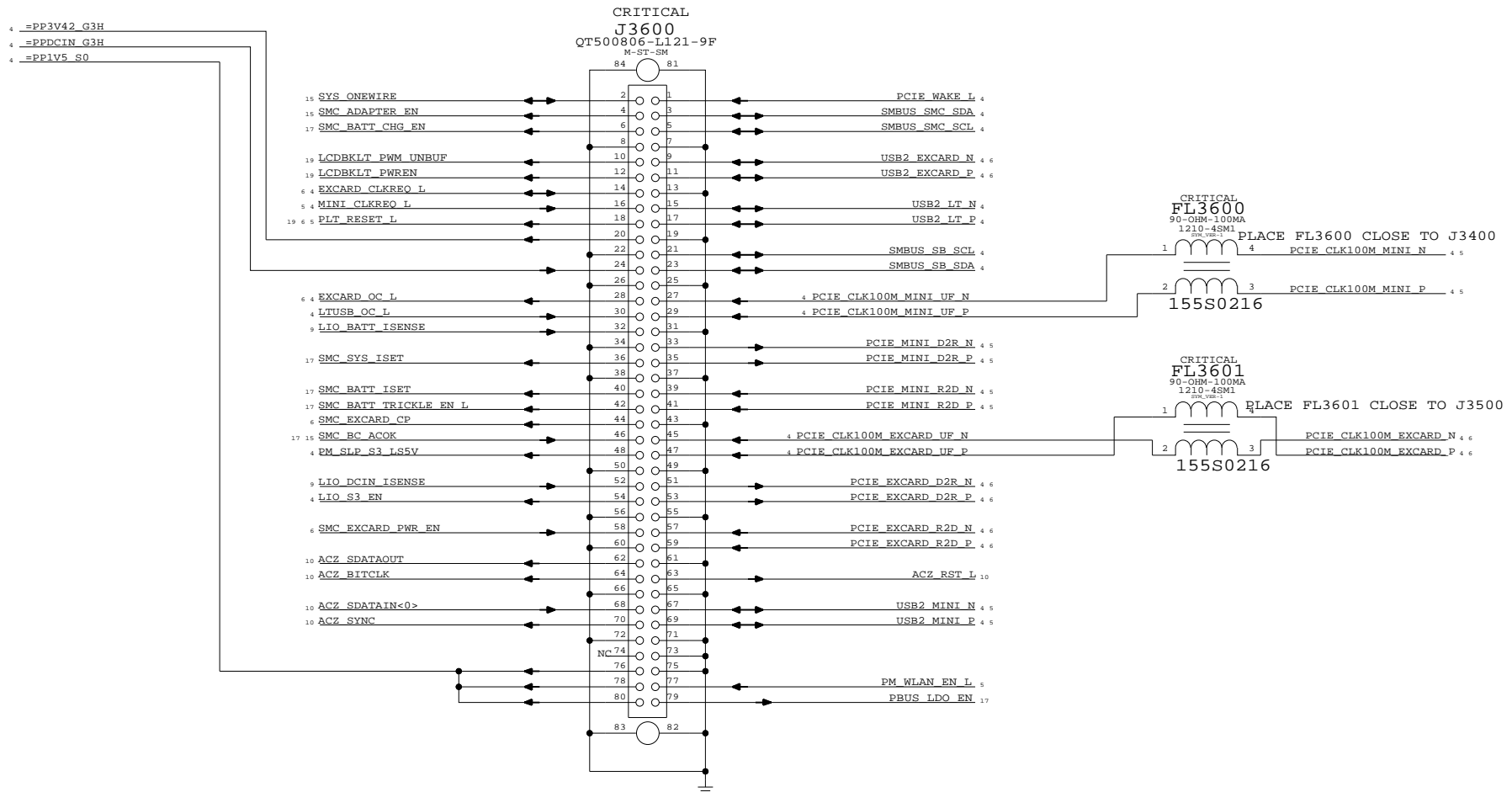

MLB I/O Board Connector

SYNC_MASTER=(Master) SYNC_DATE=(Master)

NOTICE OF PROPRIETARY PROPERTY

THE INFORMATION CONTAINED HEREIN IS THE PROPRIETARY PROPERTY OF APPLE COMPUTER, INC. THE POSSESSOR AGREES TO THE FOLLOWING

I TO MAINTAIN THE DOCUMENT IN CONFIDENCE

II NOT TO REPRODUCE OR COPY IT

III NOT TO REVEAL OR PUBLISH IN WHOLE OR PART

APPLE COMPUTER INC.	SIZE	DRAWING NUMBER	REV.
	D	051-7226	5.0.0
SCALE	SHT OF		
NONE	7 OF		20

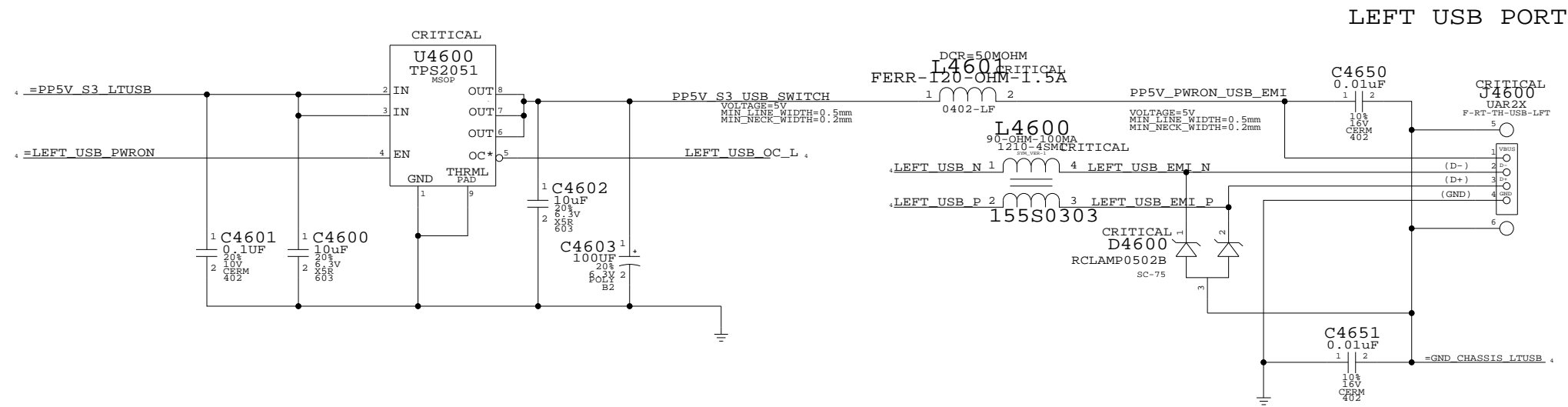

PUT L4600, L4601, ACROSS THE MOAT

Left USB Port

SYNC_MASTER=(Master) SYNC_DATE=(Master)

NOTICE OF PROPRIETARY PROPERTY

THE INFORMATION CONTAINED HEREIN IS THE PROPRIETARY PROPERTY OF APPLE COMPUTER, INC. THE POSSESSOR AGREES TO THE FOLLOWING

I TO MAINTAIN THE DOCUMENT IN CONFIDENCE

II NOT TO REPRODUCE OR COPY IT

III NOT TO REVEAL OR PUBLISH IN WHOLE OR PART

 APPLE COMPUTER INC.	SIZE	DRAWING NUMBER	REV.
	D	051-7226	5.0.0
SCALE	SHT OF		
NONE	8 OF		20

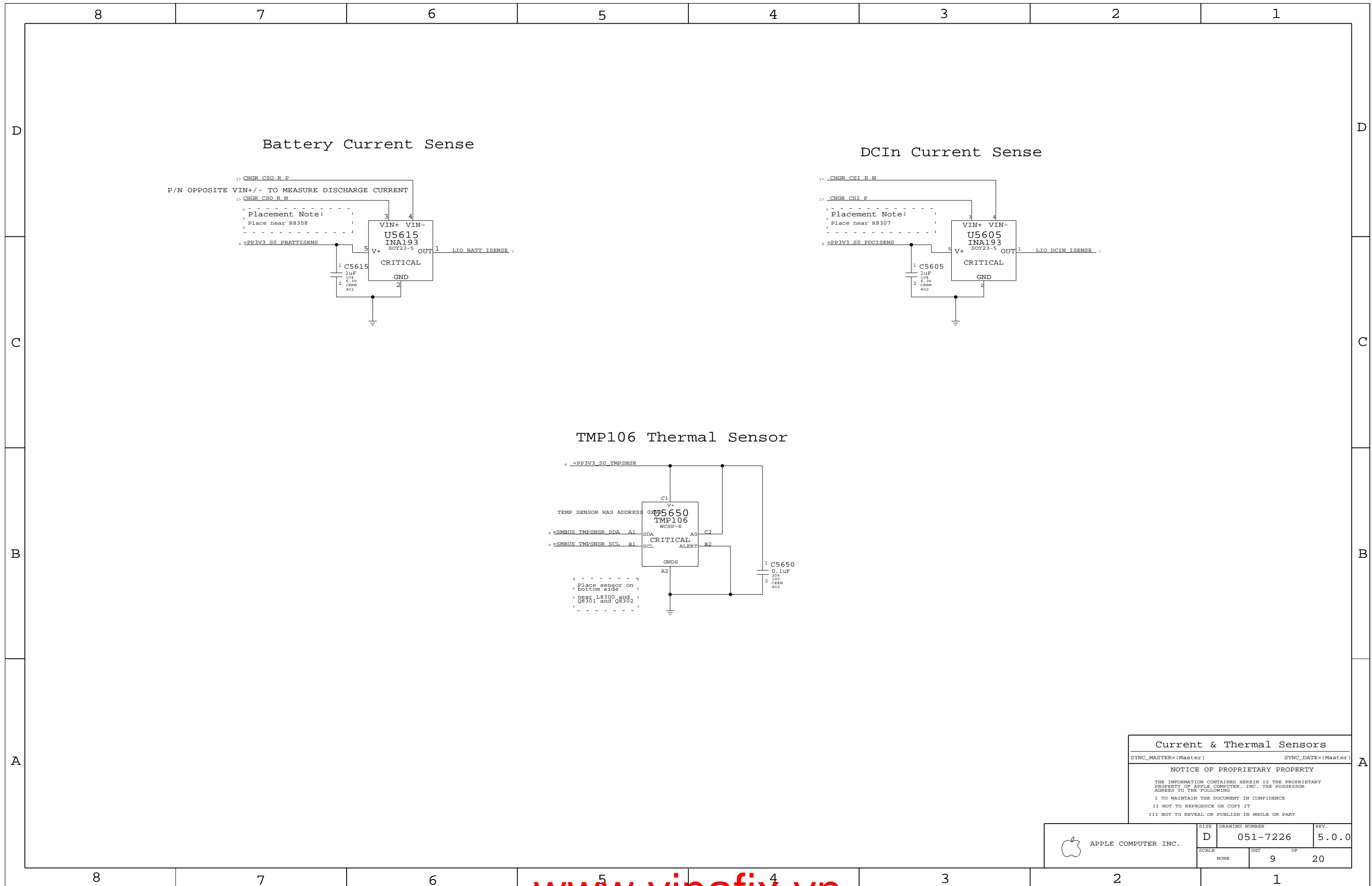

Battery Current Sense

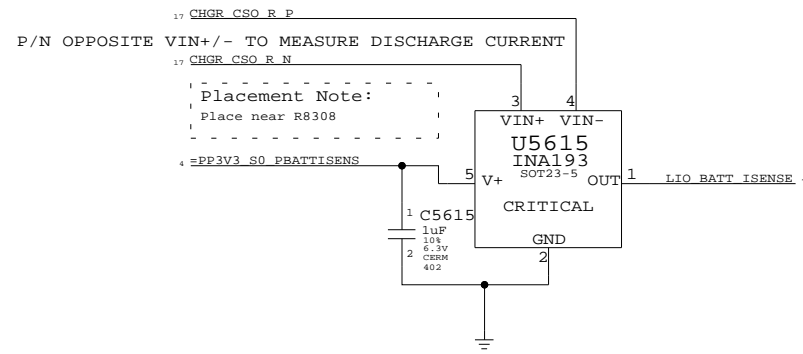

DCIn Current Sense

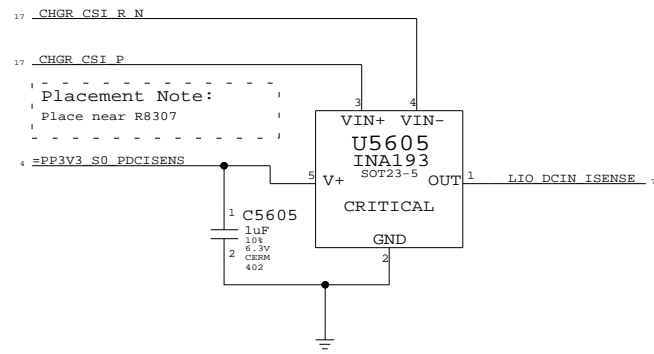

TMP106 Thermal Sensor

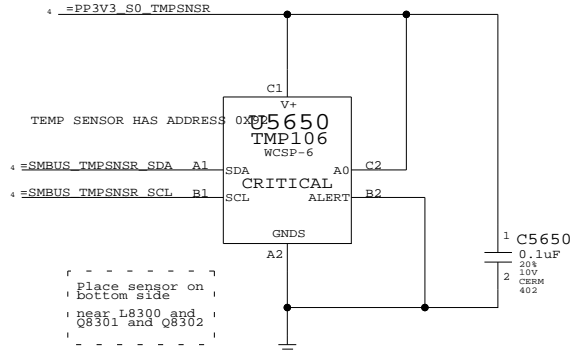

Current & Thermal Sensors
 SYNC_MASTER=(Master) SYNC_DATE=(Master)
 NOTICE OF PROPRIETARY PROPERTY
 THE INFORMATION CONTAINED HEREIN IS THE PROPRIETARY PROPERTY OF APPLE COMPUTER, INC. THE POSSESSOR AGREES TO THE FOLLOWING
 I TO MAINTAIN THE DOCUMENT IN CONFIDENCE
 II NOT TO REPRODUCE OR COPY IT
 III NOT TO REVEAL OR PUBLISH IN WHOLE OR PART

APPLE COMPUTER INC.	SIZE	DRAWING NUMBER	REV.
	D	051-7226	5.0.0
SCALE	SHT OF		
NONE	9 OF		20

AUDIO CODEC
APPLE P/N 353S1527

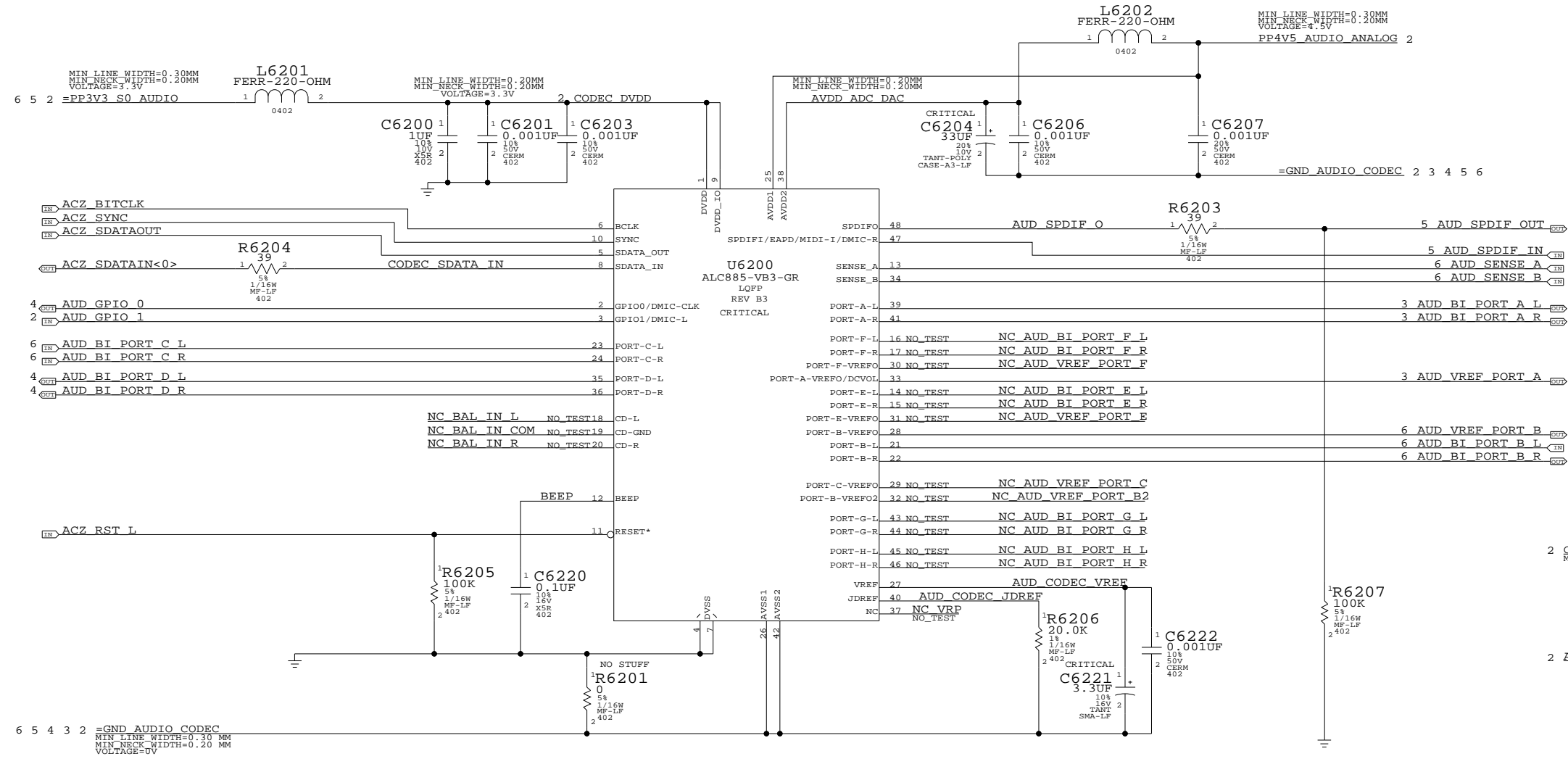

AUDIO 4.5V REGULATOR
APPLE P/N 353S1455

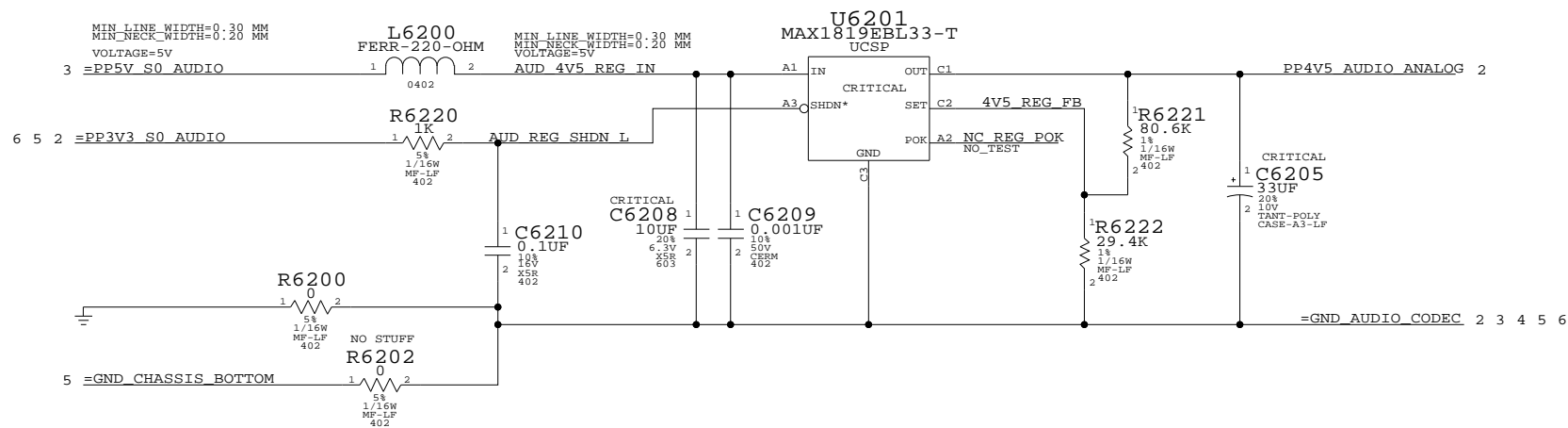

AUDIO:CODEC
 SYNC_MASTER=LENGO_M75_AUMNO_DATE=01/17/2007
 NOTICE OF PROPRIETARY PROPERTY
 THE INFORMATION CONTAINED HEREIN IS THE PROPRIETARY PROPERTY OF APPLE COMPUTER, INC. THE POSSESSOR AGREES TO THE FOLLOWING
 I TO MAINTAIN THE DOCUMENT IN CONFIDENCE
 II NOT TO REPRODUCE OR COPY IT
 III NOT TO REVEAL OR PUBLISH IN WHOLE OR PART

APPLE COMPUTER INC.	SIZE	DRAWING NUMBER	REV.
	D	051-7226	5.0.0
SCALE	SHT OF		
NONE	10		20

Headphone Amplifier (MAX9724A)

APN: 353S1637
VOLTAGE GAIN: 1.53

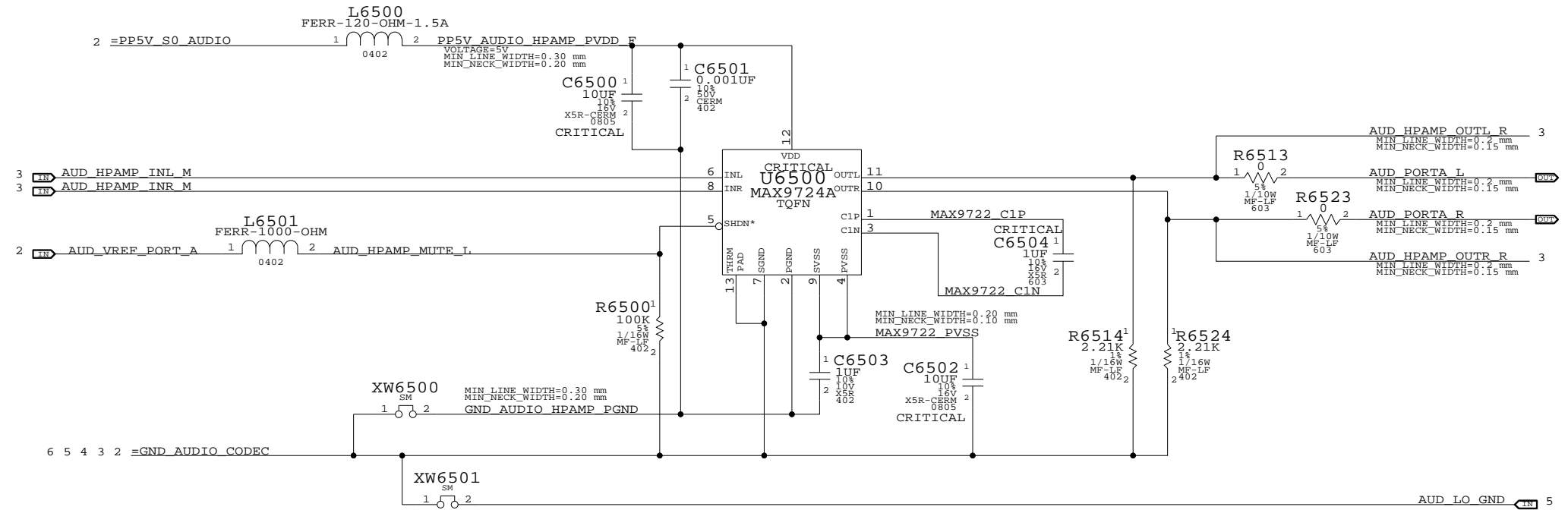

2nd Order DAC Filter

HP: 3.52 KHZ LP: 39 KHZ

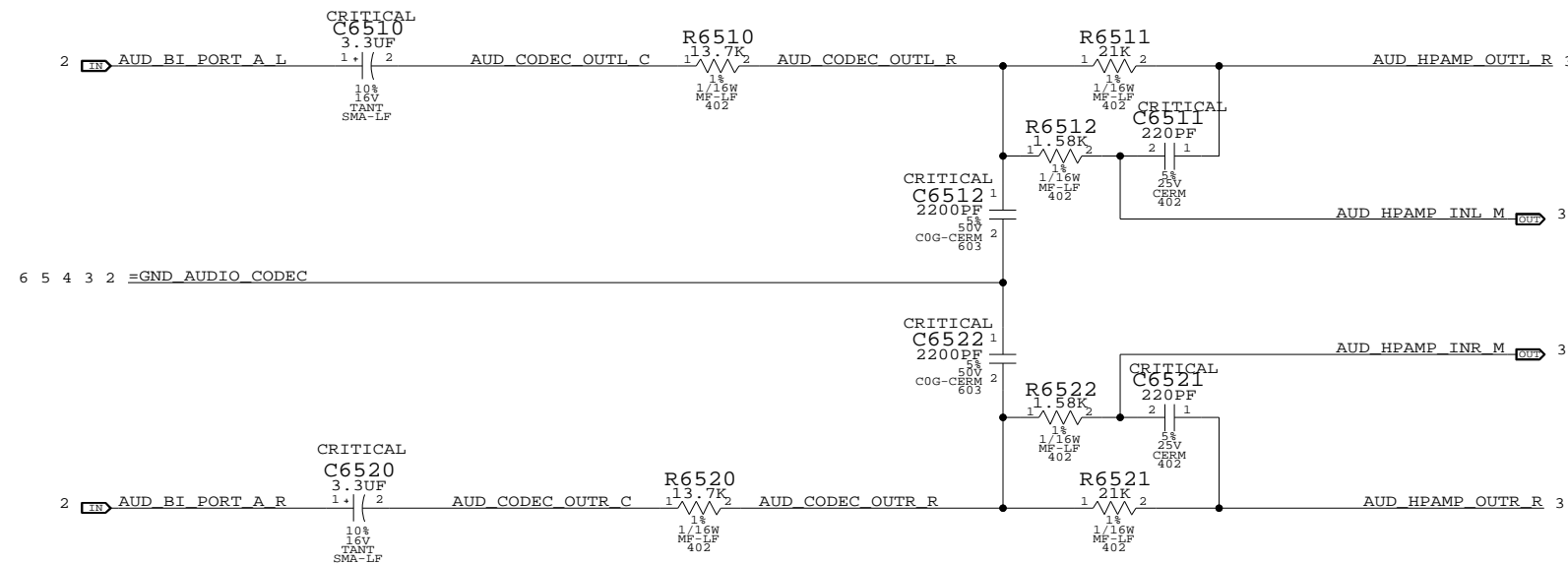

AUDIO: HEADPHONE AMP
 SYNC_MASTER=LENGO_M75_A SYNC_DATE=01/17/2007

NOTICE OF PROPRIETARY PROPERTY
 THE INFORMATION CONTAINED HEREIN IS THE PROPRIETARY PROPERTY OF APPLE COMPUTER, INC. THE POSSESSOR AGREES TO THE FOLLOWING
 I TO MAINTAIN THE DOCUMENT IN CONFIDENCE
 II NOT TO REPRODUCE OR COPY IT
 III NOT TO REVEAL OR PUBLISH IN WHOLE OR PART

APPLE COMPUTER INC.	SIZE	DRAWING NUMBER	REV.
	D	051-7226	5.0.0
SCALE	SHT	OF	
NONE	11	20	

2X MONO SPEAKER AMPLIFIERS (MAX9705B)

APN: 353S1595

GAIN = 12DB

79Hz < FC < 132Hz

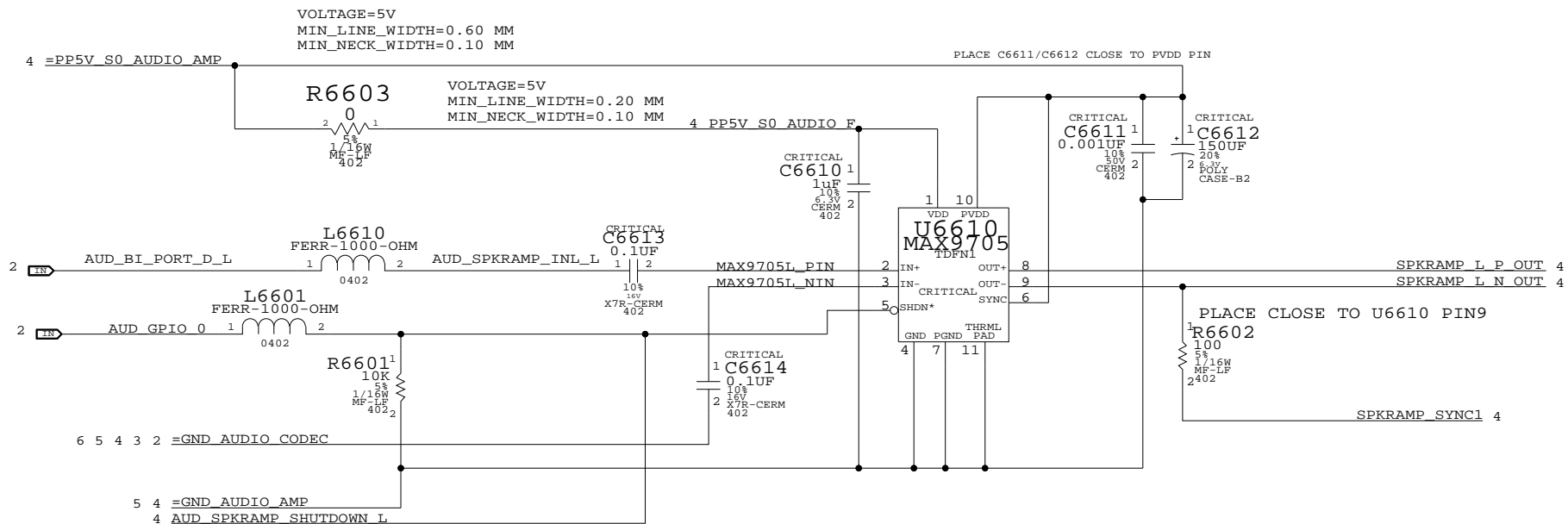

FANCY SPEAKER TESTPOINTS

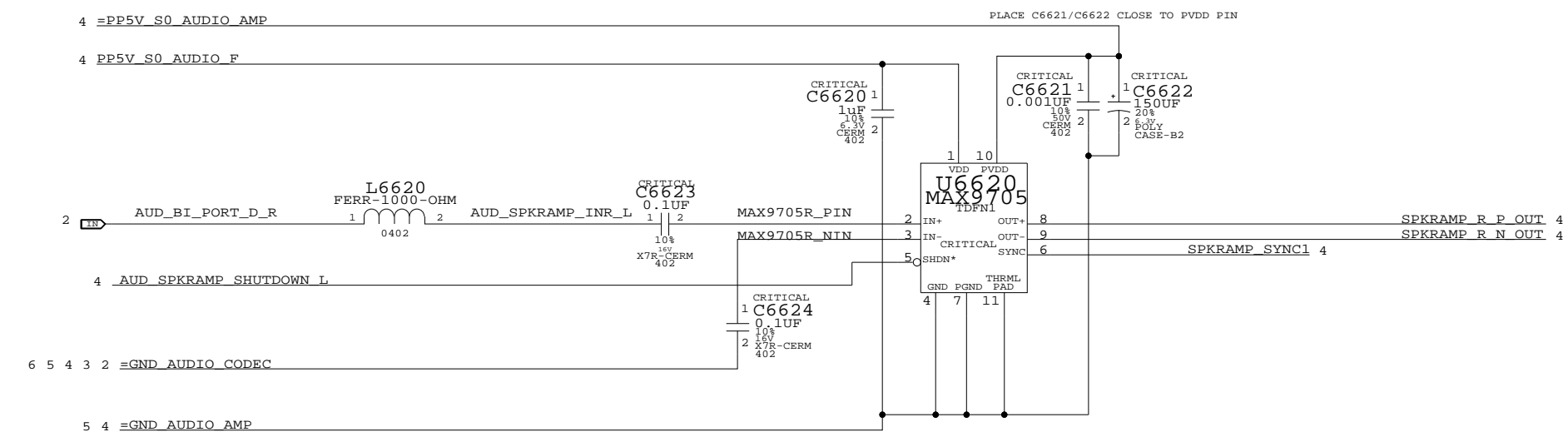
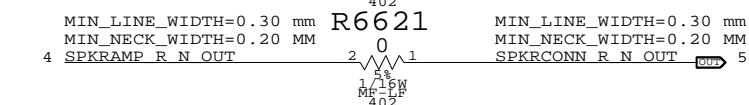
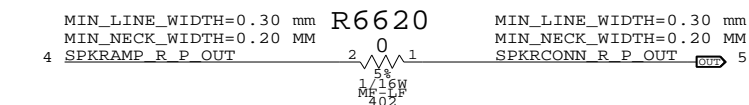
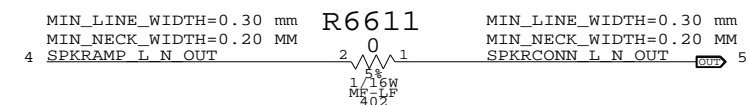
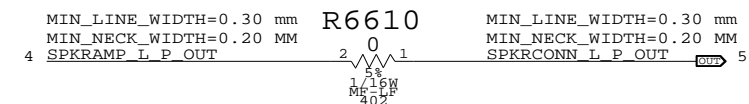

AUDIO: SPEAKER AMP

SYNC_MASTER=LENGO_M75_AUDDIO_DATE=01/17/2007

NOTICE OF PROPRIETARY PROPERTY

THE INFORMATION CONTAINED HEREIN IS THE PROPRIETARY PROPERTY OF APPLE COMPUTER, INC. THE POSSESSOR AGREES TO THE FOLLOWING
 I TO MAINTAIN THE DOCUMENT IN CONFIDENCE
 II NOT TO REPRODUCE OR COPY IT
 III NOT TO REVEAL OR PUBLISH IN WHOLE OR PART

APPLE COMPUTER INC.	SIZE	DRAWING NUMBER	REV.
	D	051-7226	5.0.0
SCALE	SHT OF		
NONE	12 OF		20

AUDIO JACK 1 LO/HP CONNECTOR, SPDIF TX

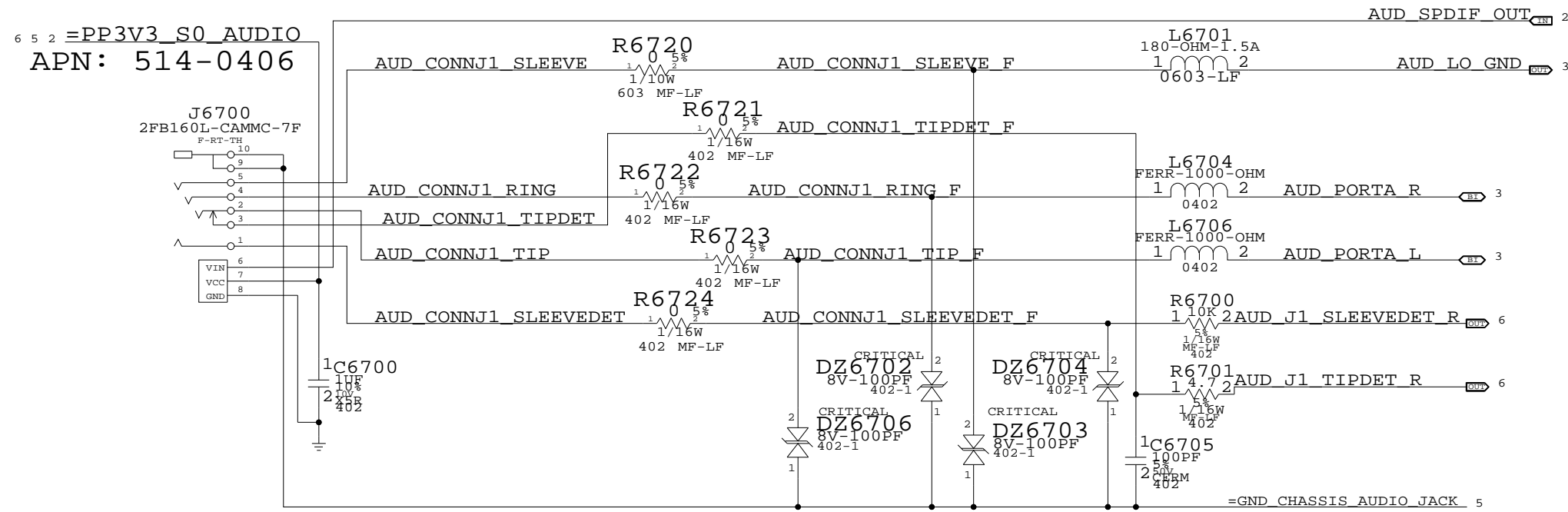

SPEAKER/MIC CONNECTOR
APN: 518-0262

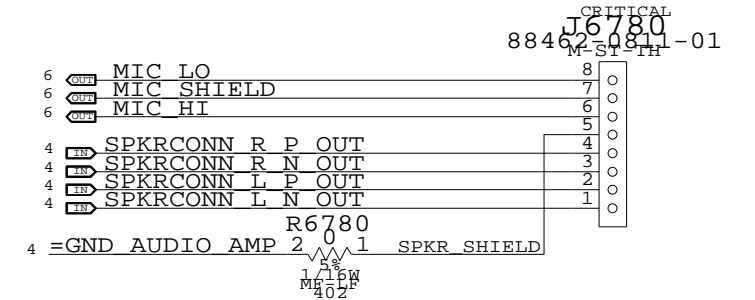

PLACE AT GROUND MOAT

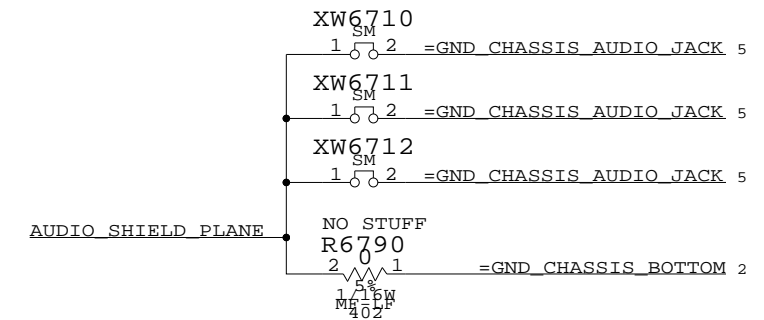
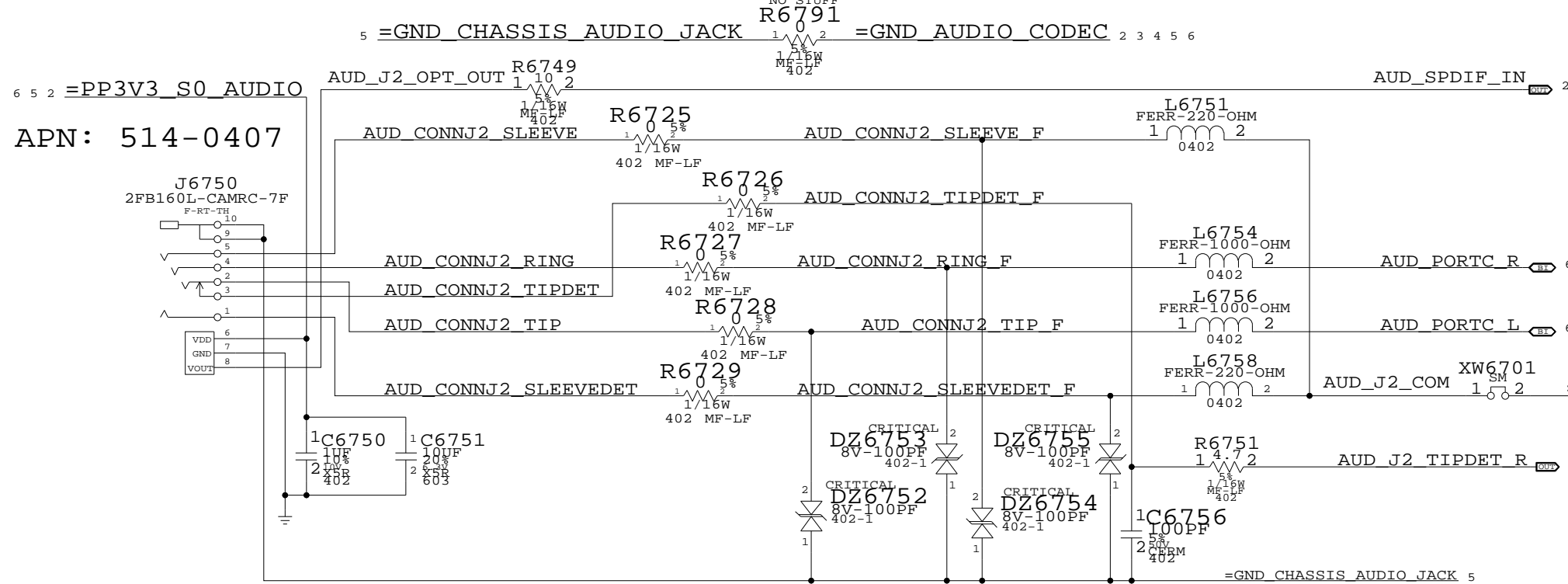

AUDIO SHIELD
(FILLED SHAPE)

AUDIO JACK 2 LINE IN CONNECTOR, SPDIF RX

AUDIO: JACKS
 SYNC_MASTER=LENGO_M75_SYNC_DATE=01/17/2007
 NOTICE OF PROPRIETARY PROPERTY
 THE INFORMATION CONTAINED HEREIN IS THE PROPRIETARY PROPERTY OF APPLE COMPUTER, INC. THE POSSESSOR AGREES TO THE FOLLOWING
 I TO MAINTAIN THE DOCUMENT IN CONFIDENCE
 II NOT TO REPRODUCE OR COPY IT
 III NOT TO REVEAL OR PUBLISH IN WHOLE OR PART

APPLE COMPUTER INC.	SIZE	DRAWING NUMBER	REV.
	D	051-7226	5.0.0
SCALE	SHT OF		
NONE	13 OF		20

CODEC OUTPUT SIGNAL PATHS

FUNCTION	VOLUME	CONVERTER	PIN COMPLEX	MUTE CONTROL	DET ASSIGNMENT
HP/LINE OUT	0x0D	0x03	0x15 (A)	VREF_A	0x15 (A)
SPEAKER	0x0C	0x02	0x14 (D)	GPIO 0	N/A
SPDIF OUT	N/A	0x06	0x1E (SPDIF OUT)	N/A	0x1B (E)

CODEC INPUT SIGNAL PATHS

FUNCTION	MIXER	CONVERTER	PIN COMPLEX	VREF	DET ASSIGNMENT
LINE IN	0x23	0x08	0x1A (C)	N/A	0x1A (C)
MIC IN	0x24	0x07	0x18 (B)	B (80%)	N/A
SPDIF IN	N/A	0x0A	0x1F (SPDIF IN)	N/A	N/A

PORT A DETECT PORT E DETECT (SPDIF DELEGATE)

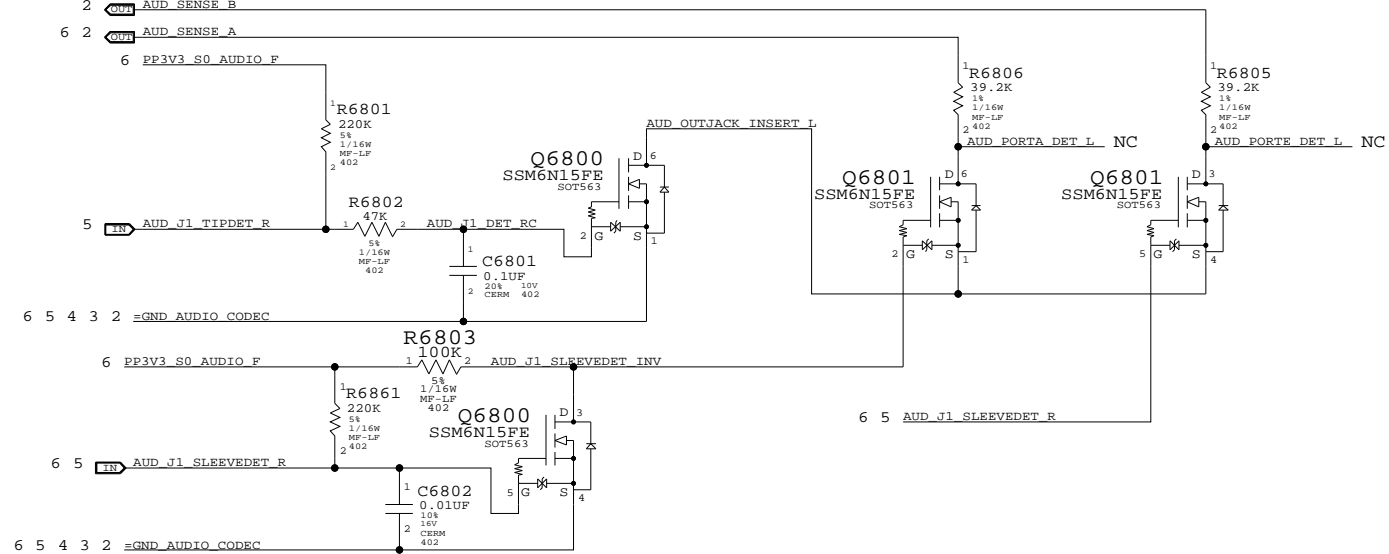

Line-in (PORT C) DETECT

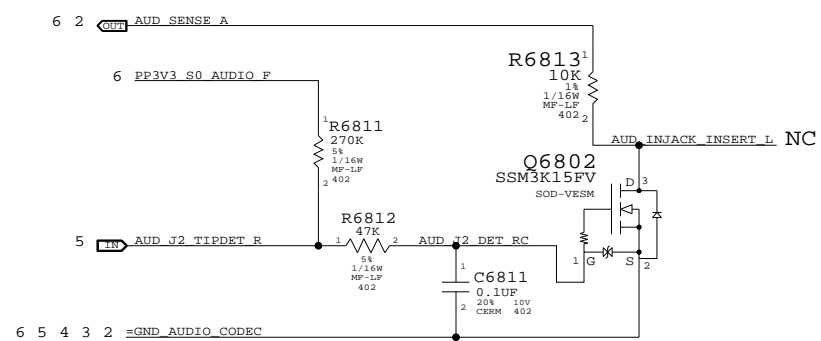

MIC INPUT CIRCUITRY

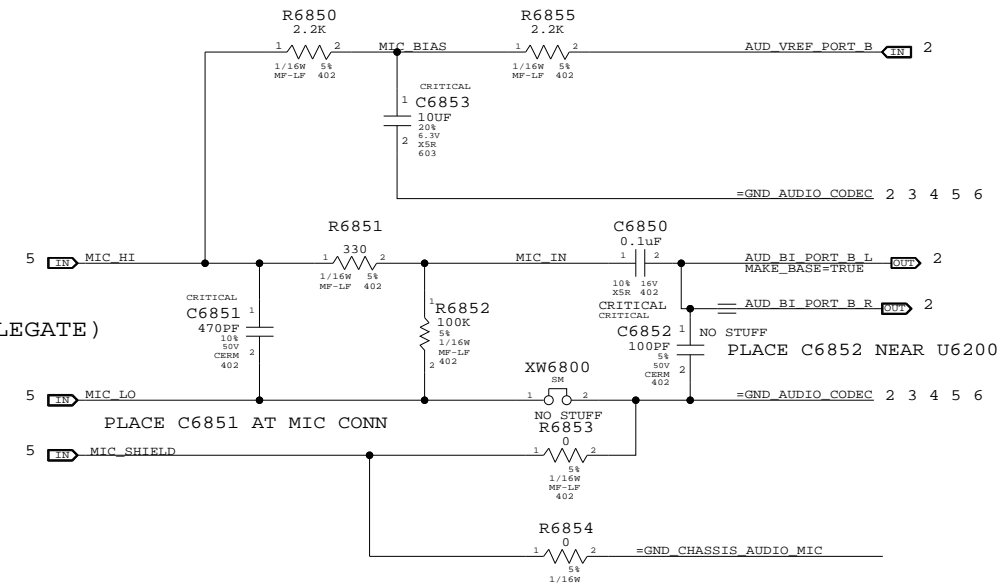

PORT C LI

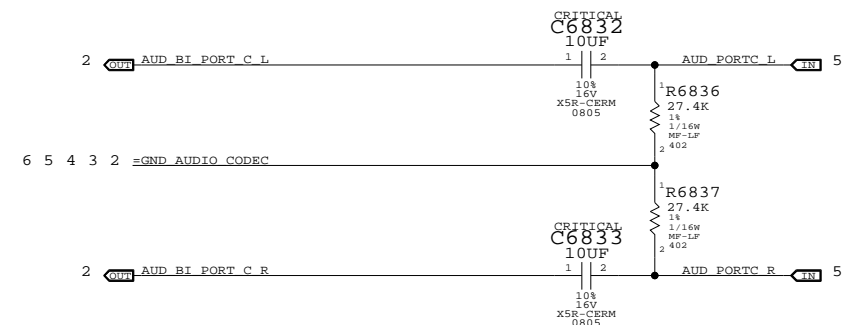

PLACE L6800/C6800 CLOSE TO Q6800/01/02

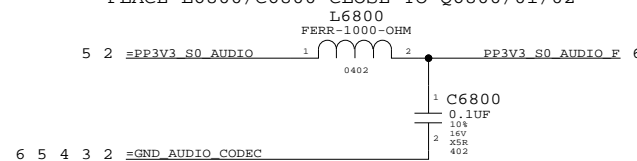

AUDIO: JACK TRANSLATORS

SYNC_MASTER=LENGO_M75_AUDIO SYNC_DATE=01/17/2007

NOTICE OF PROPRIETARY PROPERTY

THE INFORMATION CONTAINED HEREIN IS THE PROPRIETARY PROPERTY OF APPLE COMPUTER, INC. THE POSSESSOR AGREES TO THE FOLLOWING
 I TO MAINTAIN THE DOCUMENT IN CONFIDENCE
 II NOT TO REPRODUCE OR COPY IT
 III NOT TO REVEAL OR PUBLISH IN WHOLE OR PART

APPLE COMPUTER INC.	SIZE	DRAWING NUMBER	REV.
	D	051-7226	5.0.0
SCALE	SHT OF		
NONE	14 OF		20

DC Power Jack

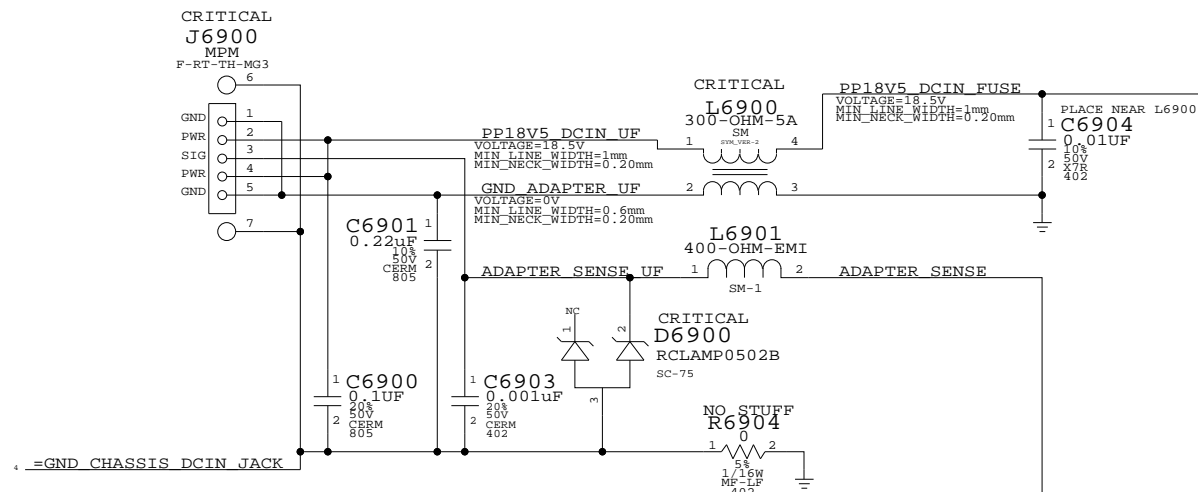

R6904 should be stuffed if GND_CHASSIS_DCIN_JACK does not have another connection to digital GND in the system, such as in an acrylic. The chassis ground will otherwise float and can send transients onto ADAPTER_SENSE when AC is connected.

1-Wire OverVoltage Protection

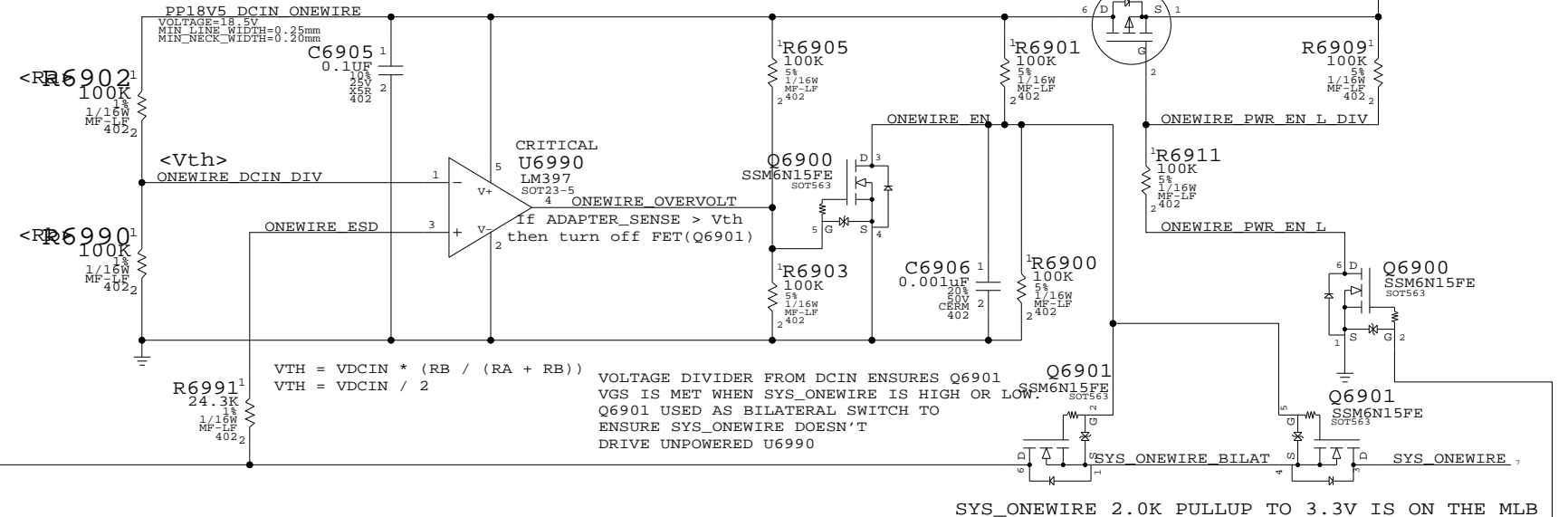

Q6909 restricts system load to 10K-70K window until adapter detects system and enables 16.5V output.

$V_{TH} = V_{DCIN} * (R_B / (R_A + R_B))$
 $V_{TH} = V_{DCIN} / 2$

VOLTAGE DIVIDER FROM DCIN ENSURES Q6901 VGS IS MET WHEN SYS_ONEWIRE IS HIGH OR LOW. Q6901 USED AS BILATERAL SWITCH TO ENSURE SYS_ONEWIRE DOESN'T DRIVE UNPOWERED U6990

SYS_ONEWIRE 2.0K PULLUP TO 3.3V IS ON THE MLB

Inrush Limiter

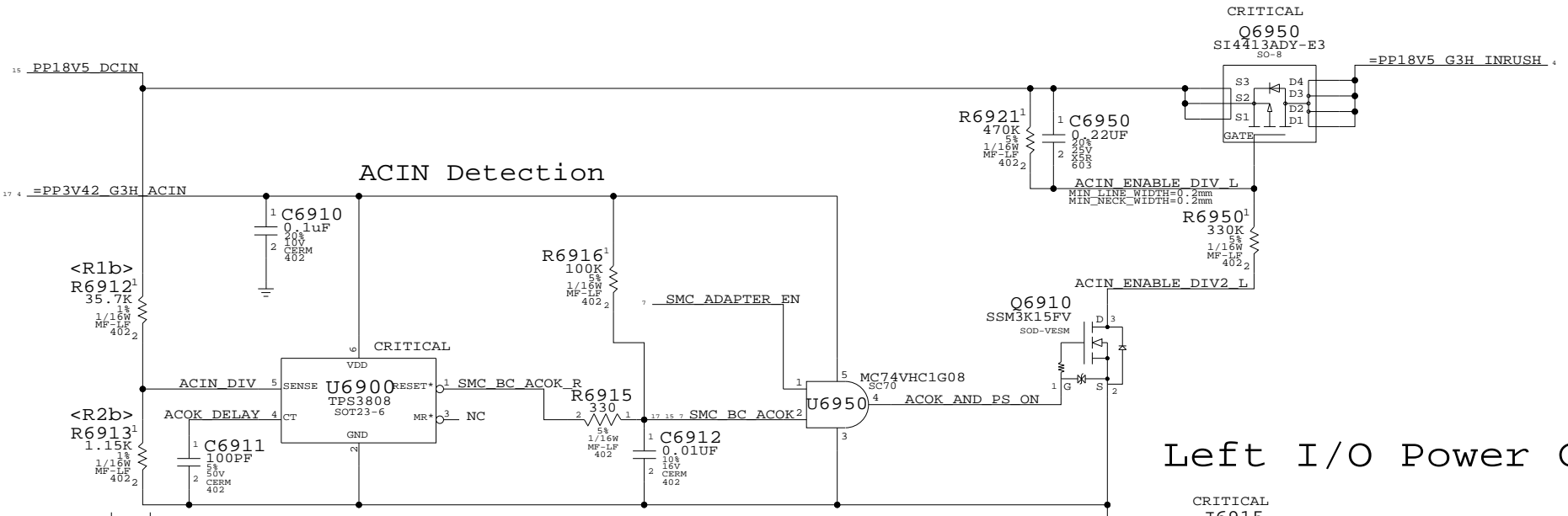

ACIN Detection

System must provide 10K-70K impedance to A52 adapter for system load detection. REQ OF R6912 & R6913 IS 36.9K.

$V_{th} = (V_{ref} / (R_{2b} / (R_{1b} + R_{2b})))$
 $V_{REF} = 0.405V$
 $V_{TH} = 13.0V$
 Assuming 1% variance for R6912-R6913 and 3.42V:
 Worst case V_{th} : min: 12.47V, max: 13.54V

Left I/O Power Connector

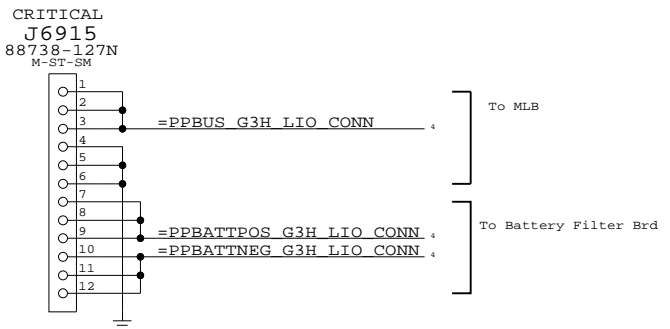

DC-In & Battery Connectors	
SYNC_MASTER=(Master)	SYNC_DATE=(Master)
NOTICE OF PROPRIETARY PROPERTY	
THE INFORMATION CONTAINED HEREIN IS THE PROPRIETARY PROPERTY OF APPLE COMPUTER, INC. THE POSSESSOR AGREES TO THE FOLLOWING	
I TO MAINTAIN THE DOCUMENT IN CONFIDENCE	
II NOT TO REPRODUCE OR COPY IT	
III NOT TO REVEAL OR PUBLISH IN WHOLE OR PART	

APPLE COMPUTER INC.	SIZE	DRAWING NUMBER	REV.
	D	051-7226	5.0.0
SCALE	SHT	OF	
NONE	15		20

5V/3.3V POWER SUPPLY

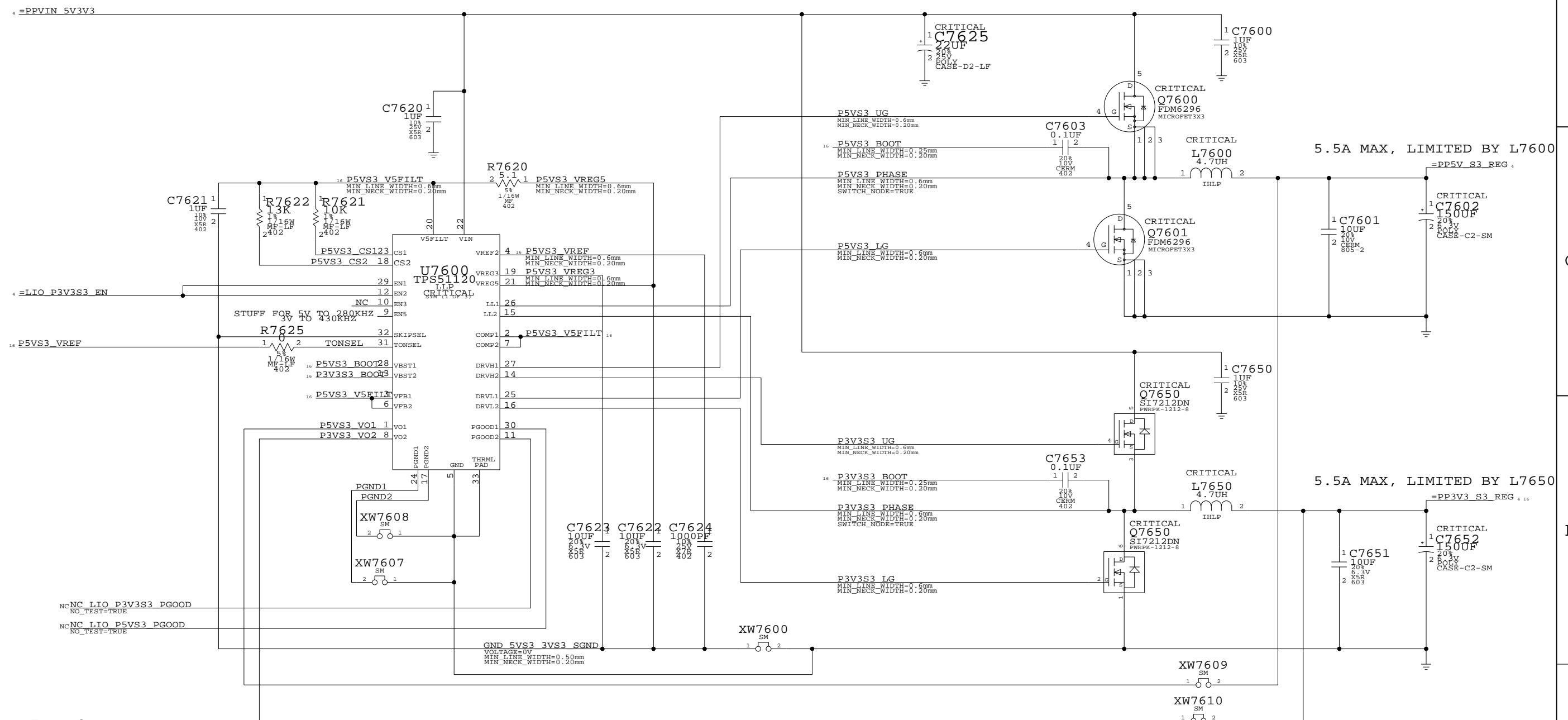

5V S0 FET

CRITICAL
Q7610
SI7913DN
PWRPK-1212-8

PLACE XW7601 TO XW76010 CLOSE TO 5V SWITCHER AND S0 FET

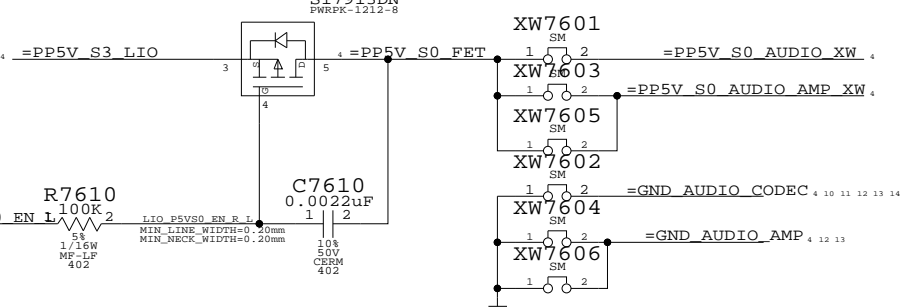

3.3V S0 FET

CRITICAL
Q7610
SI7913DN
PWRPK-1212-8

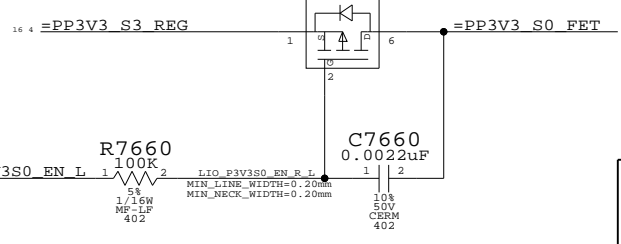

5V/3.3V SUPPLY

SYNC_MASTER=<MASTER> SYNC_DATE=<MASTER>

NOTICE OF PROPRIETARY PROPERTY

THE INFORMATION CONTAINED HEREIN IS THE PROPRIETARY PROPERTY OF APPLE COMPUTER, INC. THE POSSESSOR AGREES TO THE FOLLOWING

I TO MAINTAIN THE DOCUMENT IN CONFIDENCE

II NOT TO REPRODUCE OR COPY IT

III NOT TO REVEAL OR PUBLISH IN WHOLE OR PART

APPLE COMPUTER INC.	SIZE D	DRAWING NUMBER 051-7226	REV. 5.0.0
	SCALE NONE	SHEET OF 16 OF 20	

PBus Supply & Battery Charger

CRITICAL
Q7900
SI4413ADY-E3
SO-8

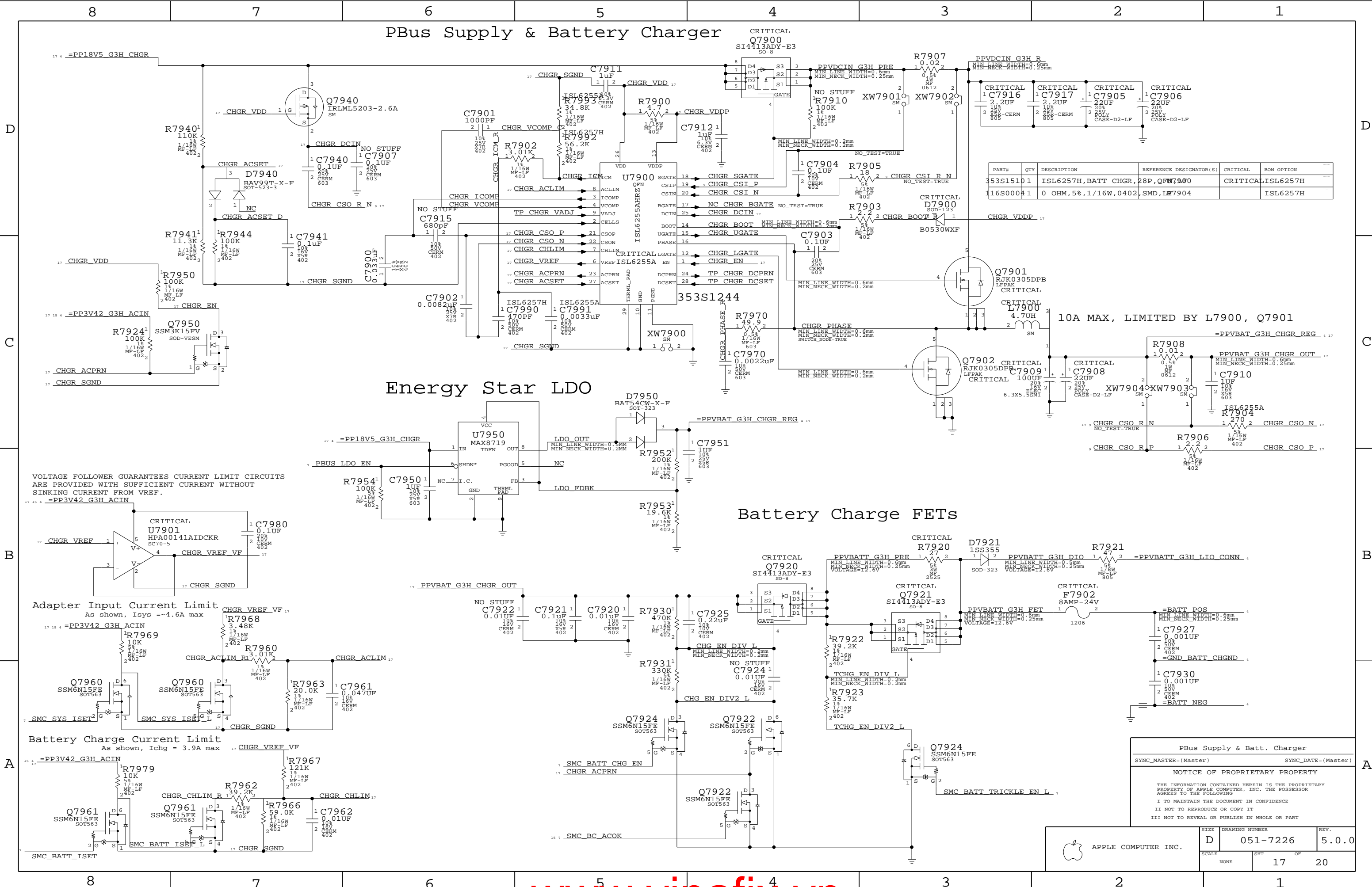

PART#	QTY	DESCRIPTION	REFERENCE DESIGNATOR(S)	CRITICAL	BOM OPTION
353S1510	1	ISL6257H, BATT CHGR, 28P, QFN	U7900	CRITICAL	ISL6257H
116S0004	1	0 OHM, 5%, 1/16W, 0402	R7904		ISL6257H

Energy Star LDO

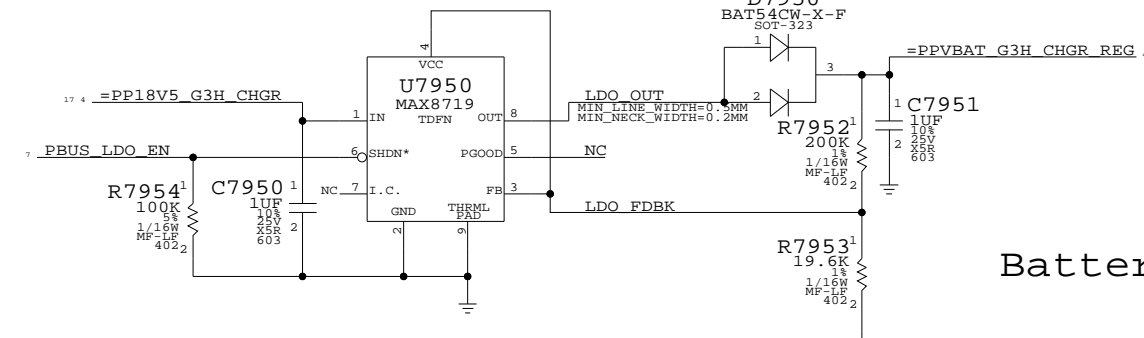

VOLTAGE FOLLOWER GUARANTEES CURRENT LIMIT CIRCUITS ARE PROVIDED WITH SUFFICIENT CURRENT WITHOUT SINKING CURRENT FROM VREF.

Battery Charge FETs

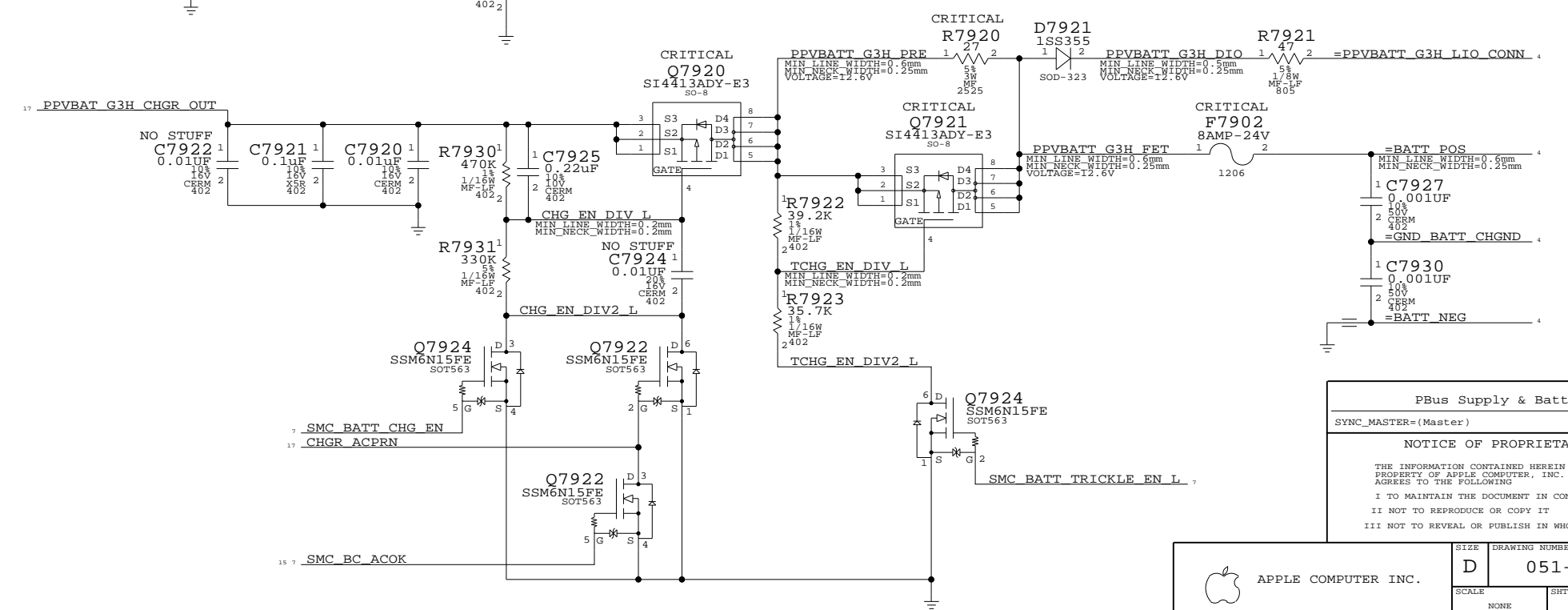

Adapter Input Current Limit

As shown, Isys = ~4.6A max

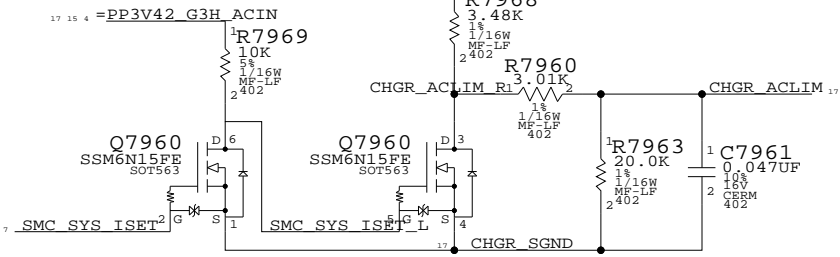

Battery Charge Current Limit

As shown, Ichg = 3.9A max

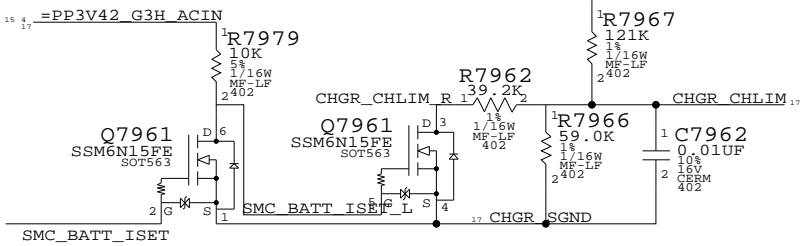

PBus Supply & Batt. Charger

SYNC_MASTER=(Master) SYNC_DATE=(Master)

NOTICE OF PROPRIETARY PROPERTY

THE INFORMATION CONTAINED HEREIN IS THE PROPRIETARY PROPERTY OF APPLE COMPUTER, INC. THE POSSESSOR AGREES TO THE FOLLOWING:
I TO MAINTAIN THE DOCUMENT IN CONFIDENCE
II NOT TO REPRODUCE OR COPY IT
III NOT TO REVEAL OR PUBLISH IN WHOLE OR PART

APPLE COMPUTER INC.	SIZE	DRAWING NUMBER	REV.
	D	051-7226	5.0.0
SCALE	SHEET	OF	
NONE	17	20	

8

7

6

5

4

3

2

1

D

D

C

C

B

B

A

A

Inverter Connector

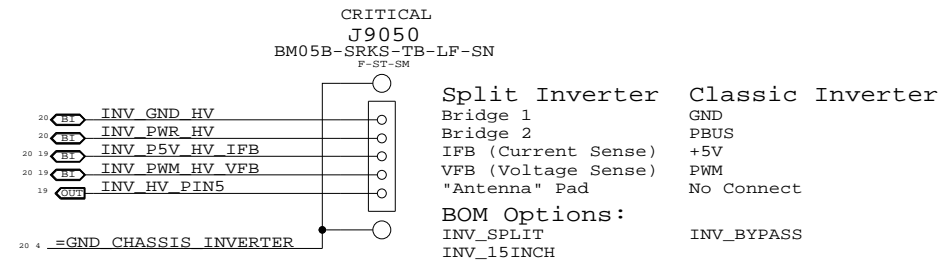

Inverter Connector
 SYNC_MASTER=SPLIT_INVERTER SYNC_DATE=12/06/2006

NOTICE OF PROPRIETARY PROPERTY
 THE INFORMATION CONTAINED HEREIN IS THE PROPRIETARY PROPERTY OF APPLE COMPUTER, INC. THE POSSESSOR AGREES TO THE FOLLOWING
 I TO MAINTAIN THE DOCUMENT IN CONFIDENCE
 II NOT TO REPRODUCE OR COPY IT
 III NOT TO REVEAL OR PUBLISH IN WHOLE OR PART

APPLE COMPUTER INC.	SIZE	DRAWING NUMBER	REV.
	D	051-7226	5.0.0
SCALE	SHT OF		
NONE	18 OF 20		

8

7

6

5

4

3

2

1

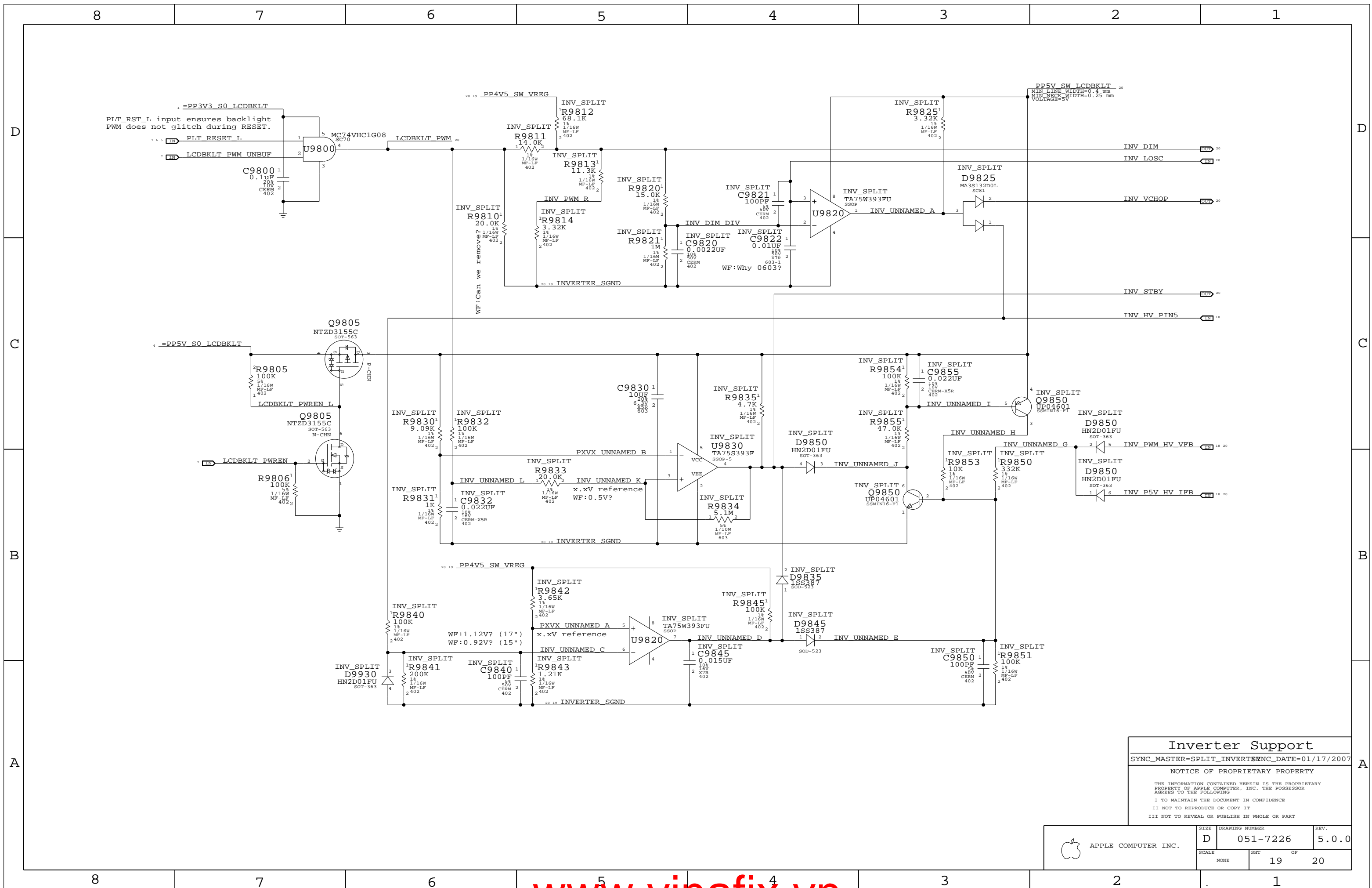

Inverter Support
 SYNC_MASTER=SPLIT_INVERTERXNC_DATE=01/17/2007

NOTICE OF PROPRIETARY PROPERTY

THE INFORMATION CONTAINED HEREIN IS THE PROPRIETARY PROPERTY OF APPLE COMPUTER, INC. THE POSSESSOR AGREES TO THE FOLLOWING

I TO MAINTAIN THE DOCUMENT IN CONFIDENCE
 II NOT TO REPRODUCE OR COPY IT
 III NOT TO REVEAL OR PUBLISH IN WHOLE OR PART

APPLE COMPUTER INC.	SIZE	DRAWING NUMBER	REV.
	D	051-7226	5.0.0
SCALE		SHT	OF
NONE		19	20

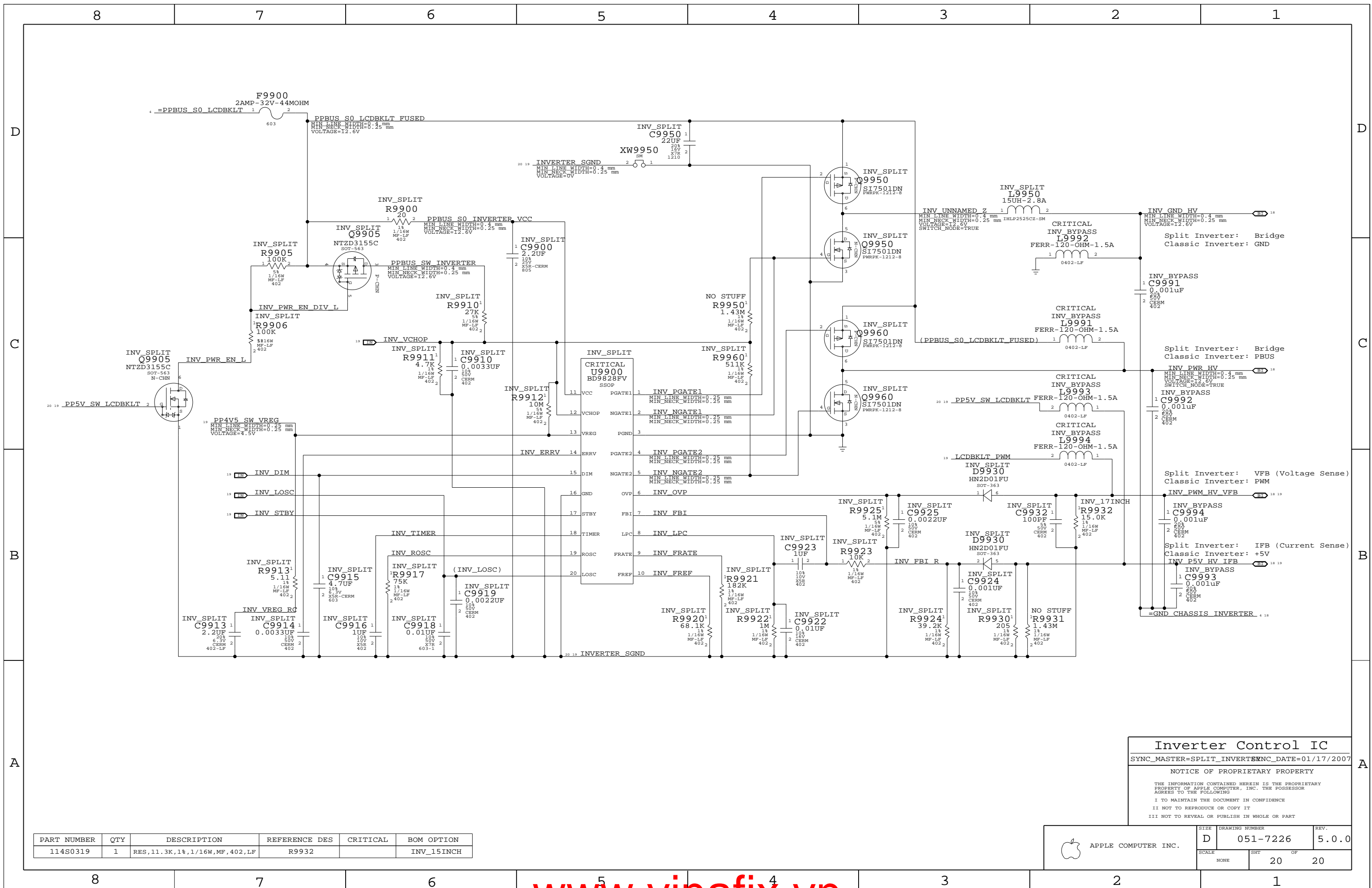

Inverter Control IC

SYNC_MASTER=SPLIT_INVERTER;MNC_DATE=01/17/2007

NOTICE OF PROPRIETARY PROPERTY

THE INFORMATION CONTAINED HEREIN IS THE PROPRIETARY PROPERTY OF APPLE COMPUTER, INC. THE POSSESSOR AGREES TO THE FOLLOWING
 I TO MAINTAIN THE DOCUMENT IN CONFIDENCE
 II NOT TO REPRODUCE OR COPY IT
 III NOT TO REVEAL OR PUBLISH IN WHOLE OR PART

PART NUMBER	QTY	DESCRIPTION	REFERENCE DES	CRITICAL	BOM OPTION
114S0319	1	RES, 11.3K, 1%, 1/16W, MF, 402, LF	R9932		INV_15INCH

APPLE COMPUTER INC.	SIZE	DRAWING NUMBER	REV.
	D	051-7226	5.0.0
SCALE	SHT	OF	
NONE	20	20	