

Annika Block Diagram

PCB STACK UP

6L

- LAYER 1 : TOP
- LAYER 2 : SGND
- LAYER 3 : IN1
- LAYER 4 : IN2
- LAYER 5 : VCC
- LAYER 6 : BOT

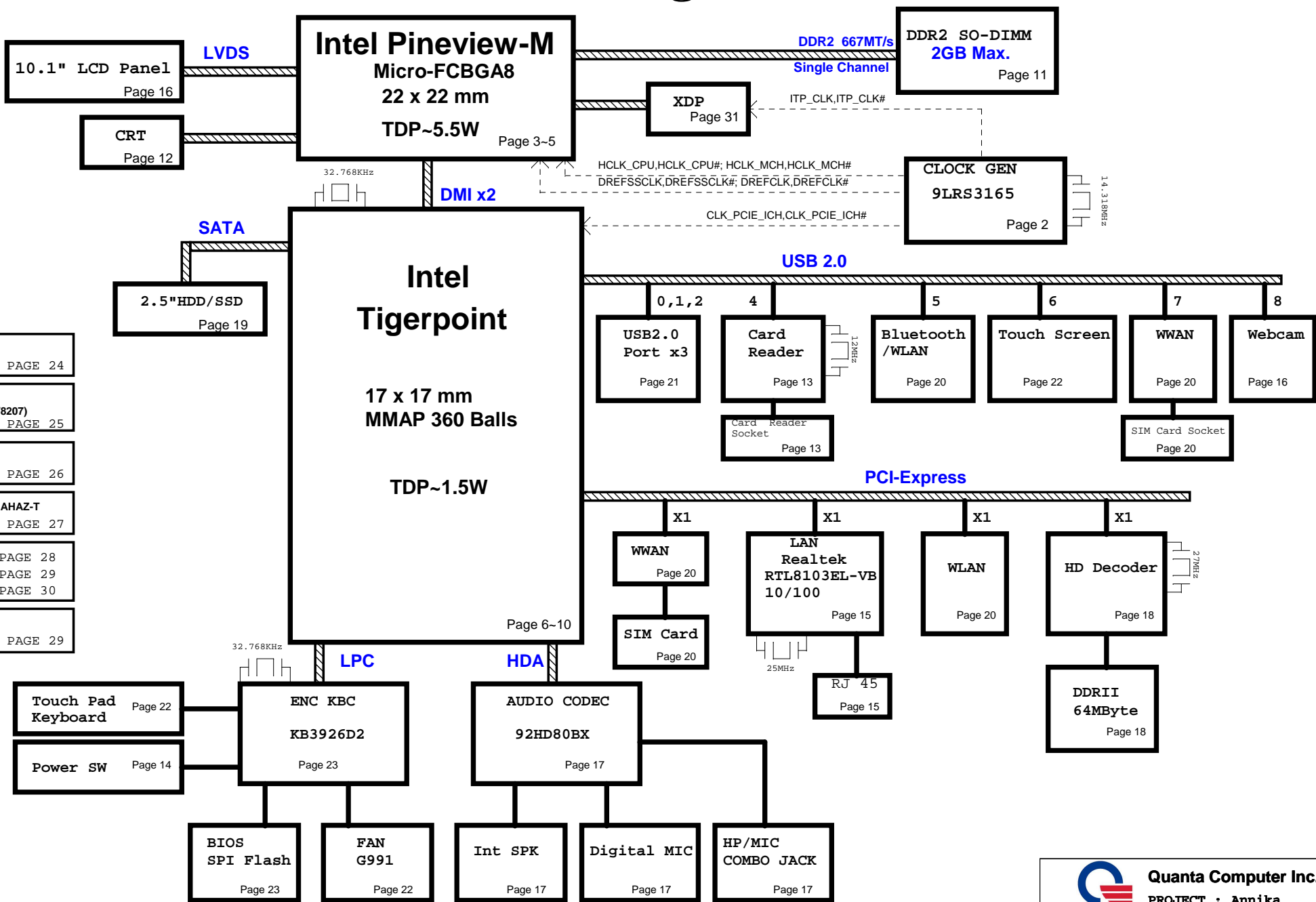

Quanta Computer Inc. PROJECT : Annika		Rev. 1A
Date: Friday, October 30, 2009	Sheet 1 of 32	

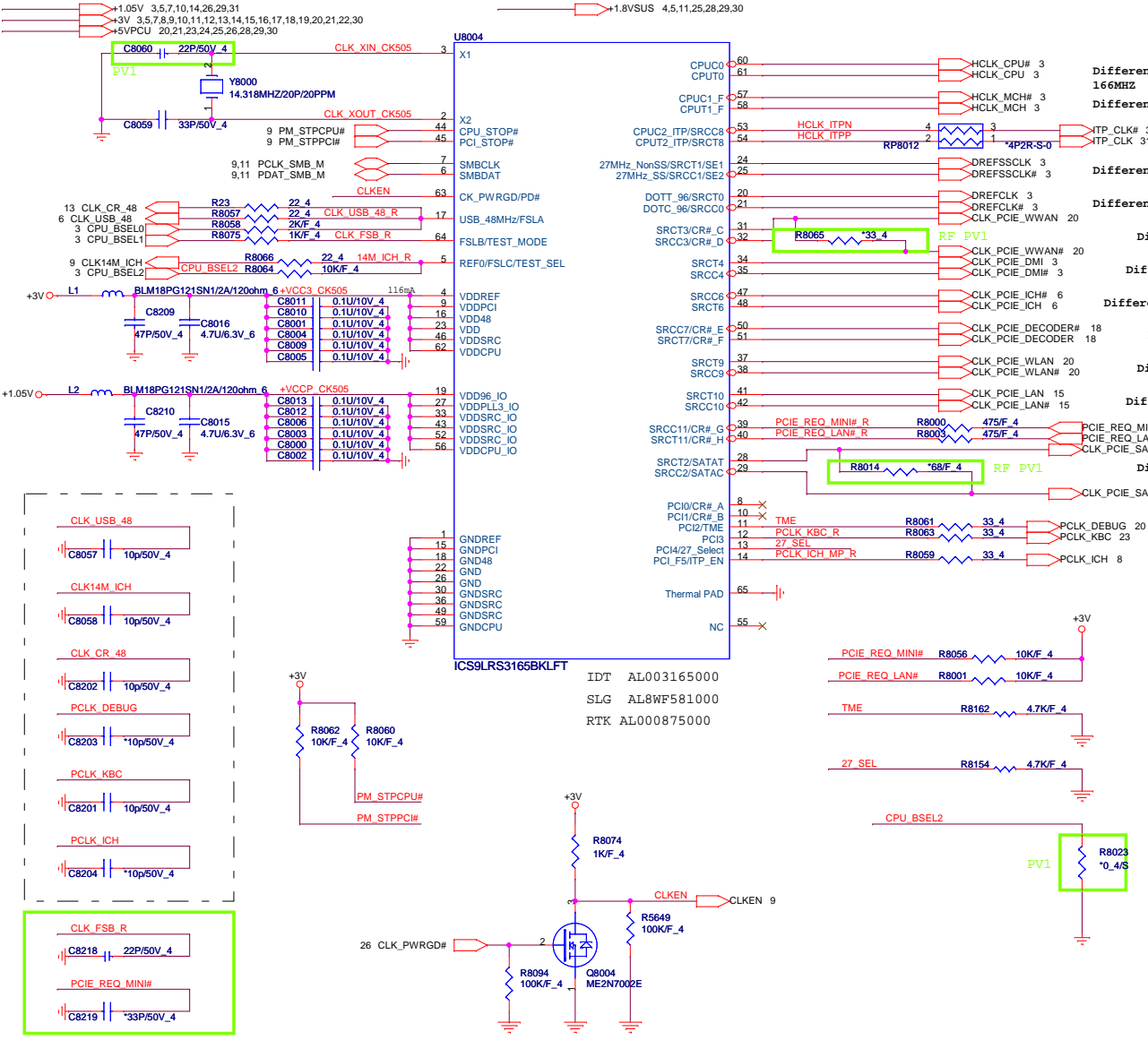

- Differential Core clk 166MHz
- Differential HOST clk 166MHz
- Differential ITP clk 166MHz
- Differential SSC clk 100MHz
- Differential PLL clk 96MHz
- Differential WWAN PCIE clk 100MHz
- Differential Pine view DMI clk 100MHz
- Differential TP DMI clk 100MHz
- Differential HD Decoder clk 100MHz
- Differential WLAN PCIE clk 100MHz
- Differential PCIE LAN clk 100MHz
- Differential SATA clk 100MHz

27 Select	PIN13	PIN 20/21	PIN 24/25
* 0	DOT_96 / DOT_96#	LCDCLK / LCDCLK#	
1	SRC_0 / SRC_0#	27M / 27M_SS	

ITP_EN(PIN14)	PIN53/54
0	SRC8#/SRC8
* 1	ITP/ITP#

FSC BSEL2	FSB BSEL1	FSA BSEL0	CPU	SRC	PCI	REF	USB	DOT	Spread %
0	0	0	266.66	100	33.33	14.318	48	96	0.5 Down
0	0	1	133.33	100	33.33	14.318	48	96	0.5 Down
0	1	0	200.00	100	33.33	14.318	48	96	0.5 Down
0	1	1	166.66	100	33.33	14.318	48	96	0.5 Down
1	0	0	333.33	100	33.33	14.318	48	96	0.5 Down
1	0	1	100.00	100	33.33	14.318	48	96	0.5 Down
1	1	0	400.00	100	33.33	14.318	48	96	0.5 Down
1	1	1							

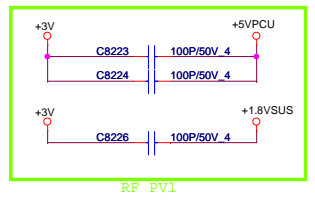

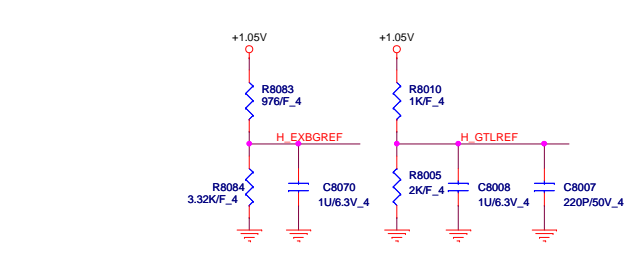
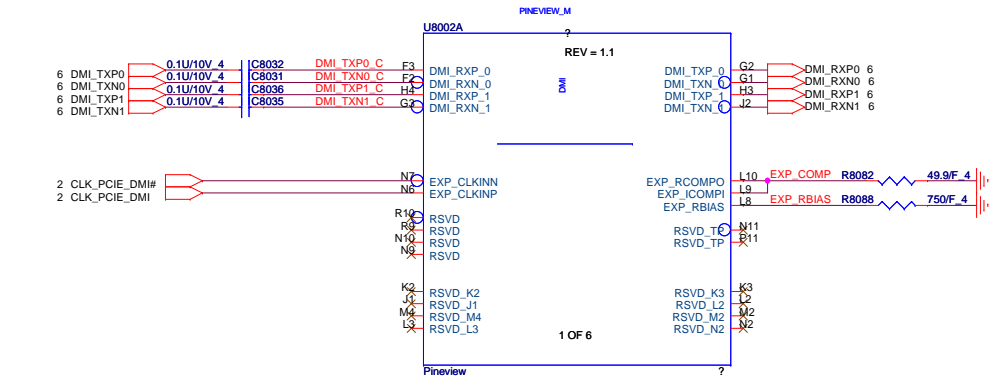
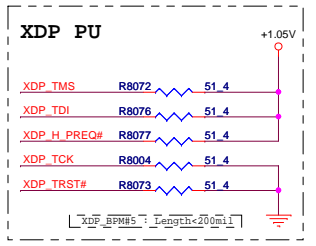
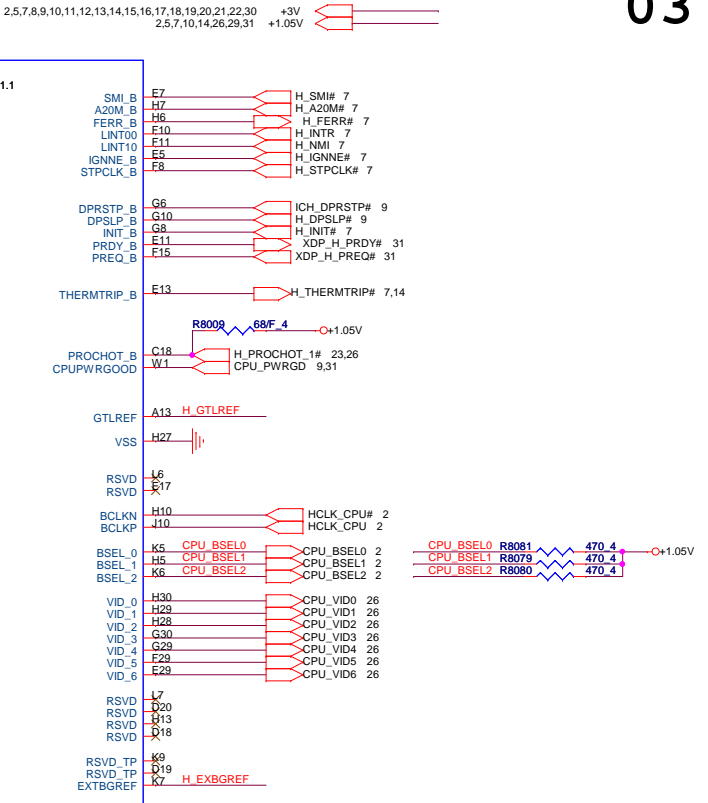
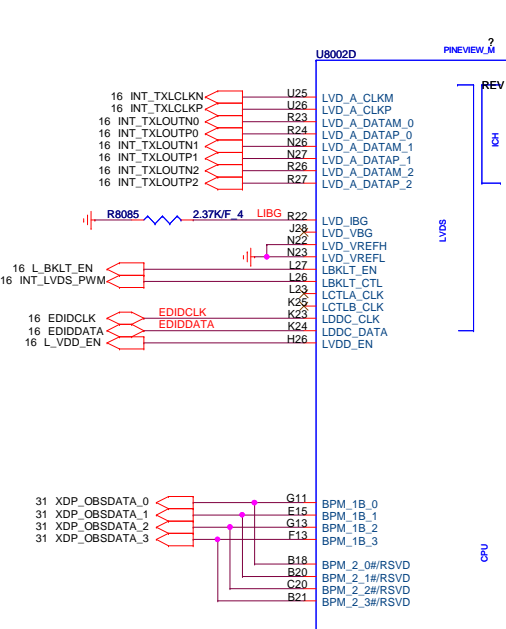
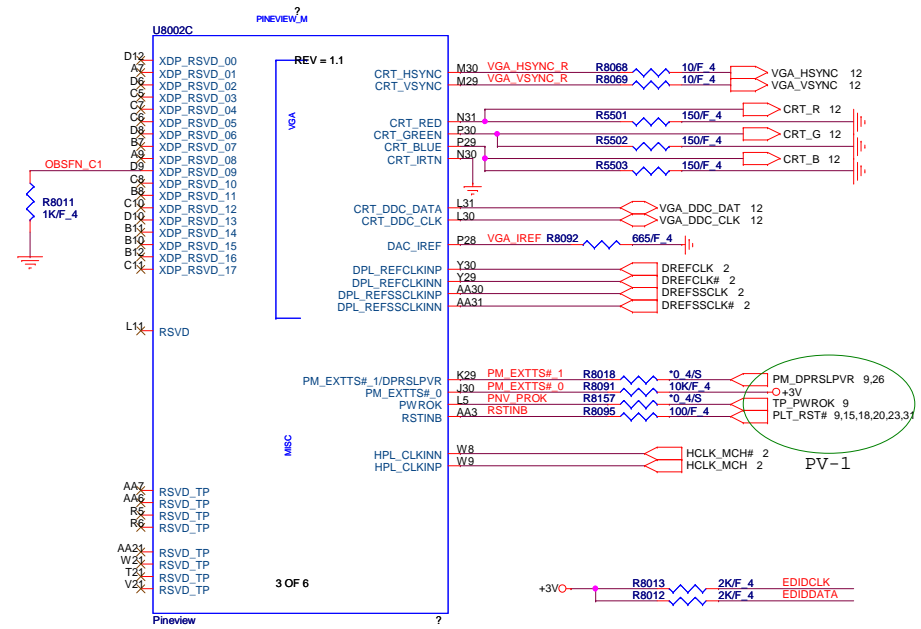

Quanta Computer Inc.
PROJECT : Annika

Size	Document Number	Rev
	Pineview DMI/Display(1/4)	1A
Date:	Thursday, October 29, 2009	Sheet 3 of 32

+1.8VSUS 2.5,11,25,28,29,30

PINEVIEW_M

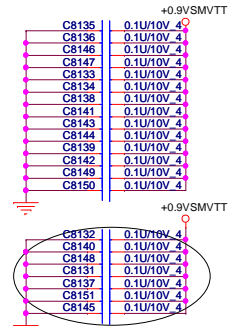
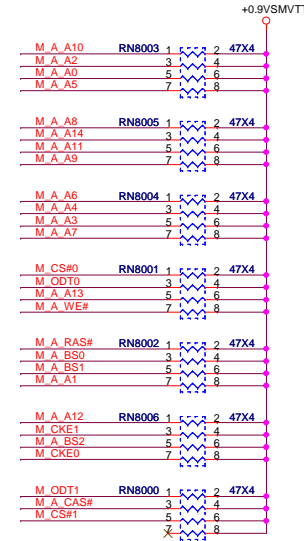
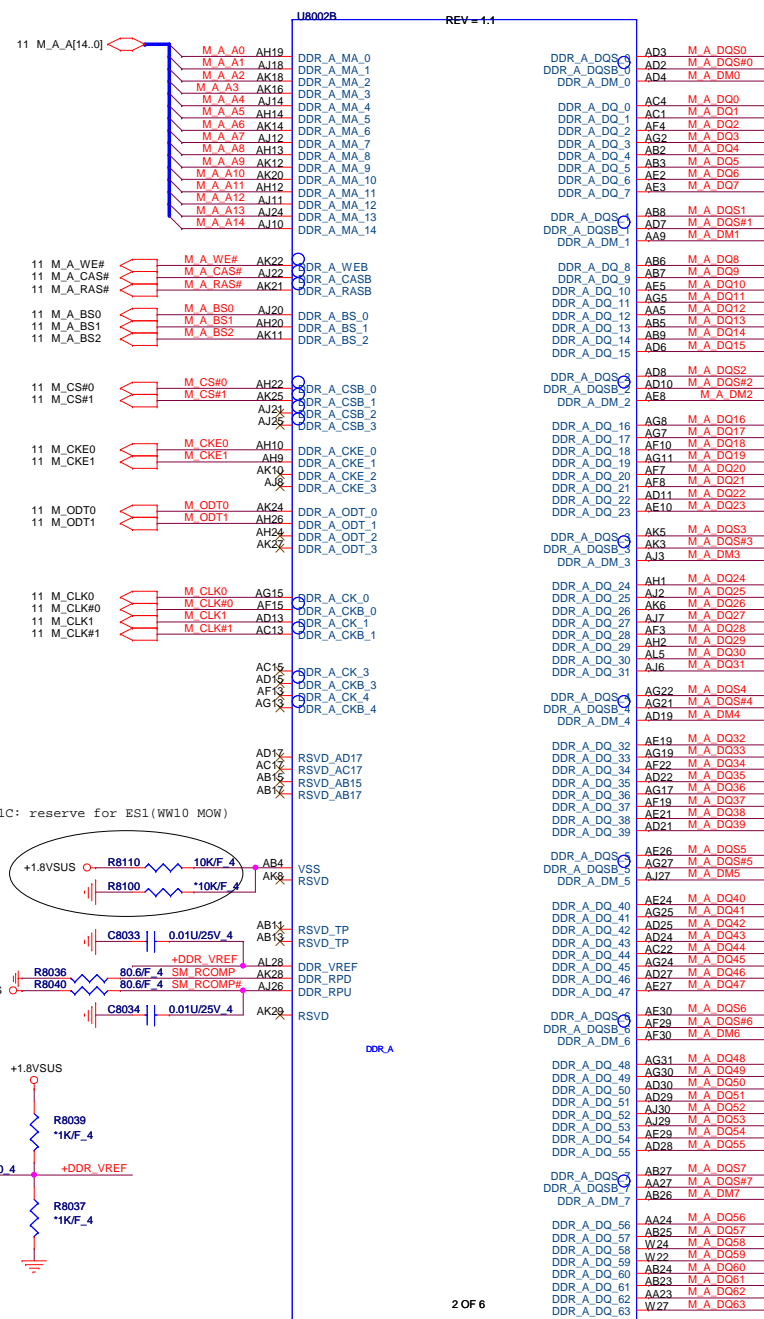

1D: add 7 0.1u for VTT_MEM(Intel)

2 OF 6

Pineview

Quanta Computer Inc.
PROJECT : Annika

Size	Document Number	Rev
	Pineview DDR(2/4)	1A
Date:	Thursday, October 29, 2009	Sheet 4 of 32

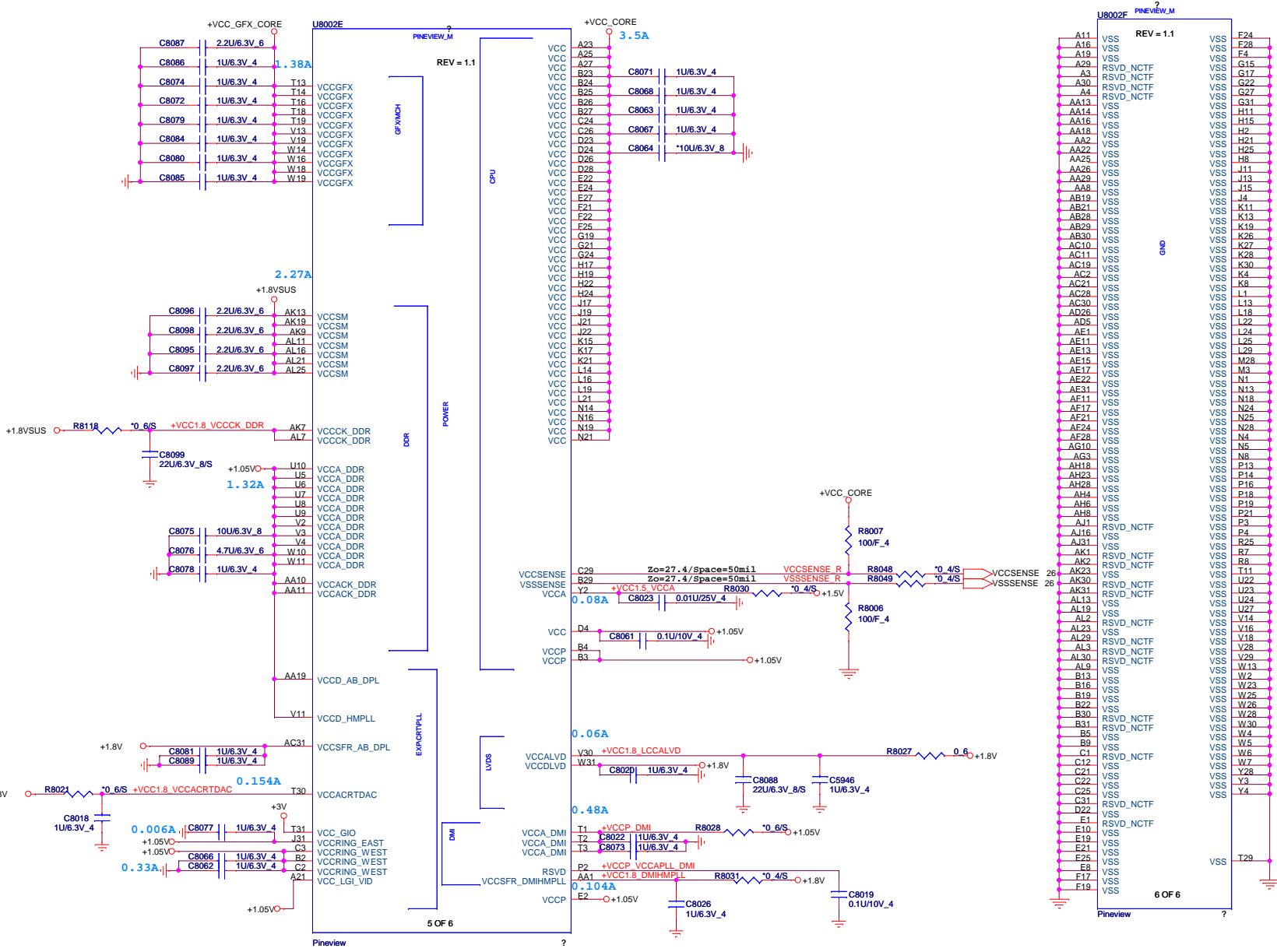

Quanta Computer Inc.
PROJECT : Annika

Size	Document Number	Rev
	Pineview Power(3/4)	1A
Date:	Thursday, October 29, 2009	Sheet 5 of 32

5,10,20,30 +1.5V
9,10,30 +3V_S5

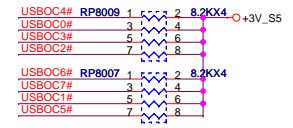
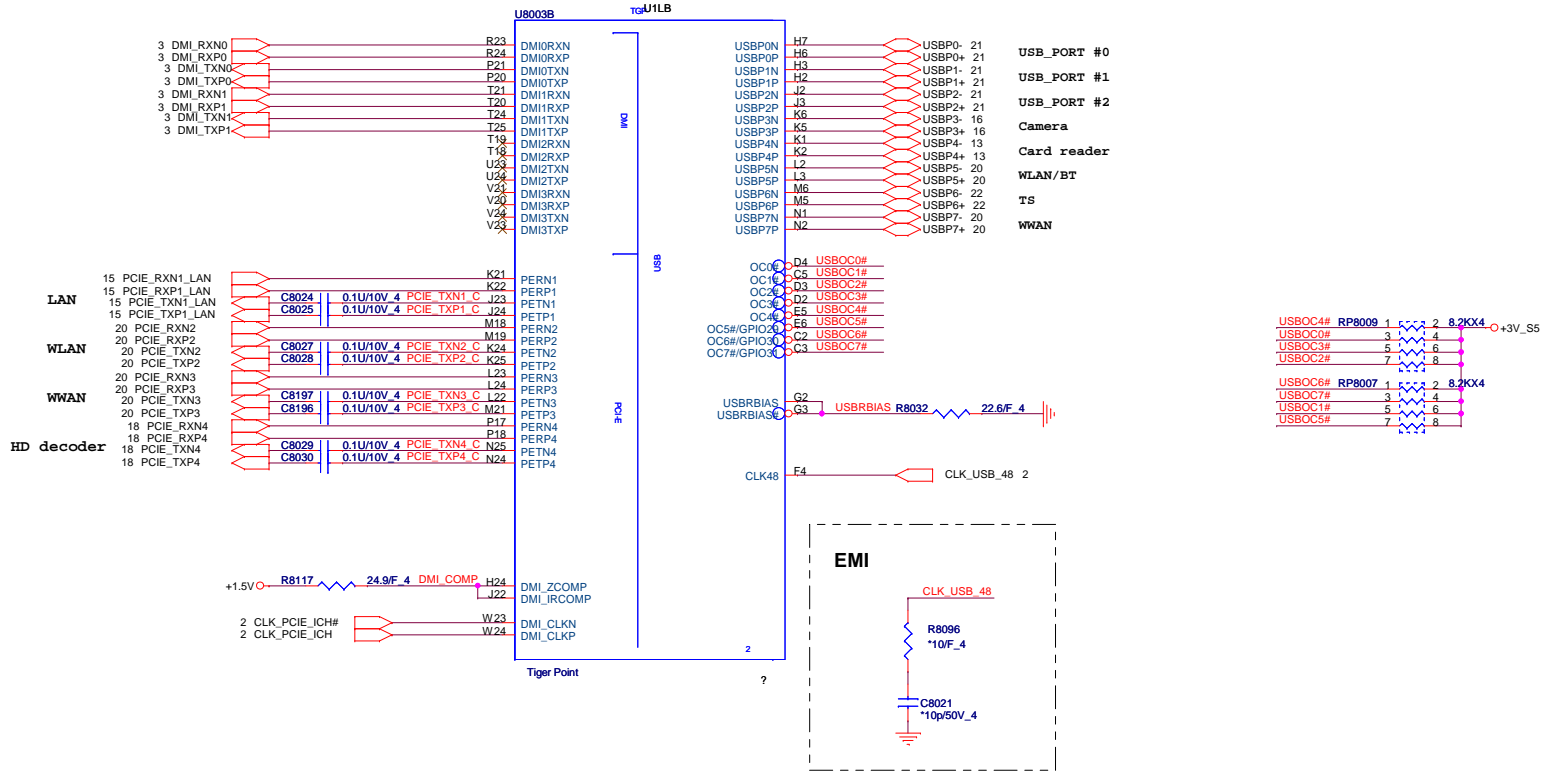

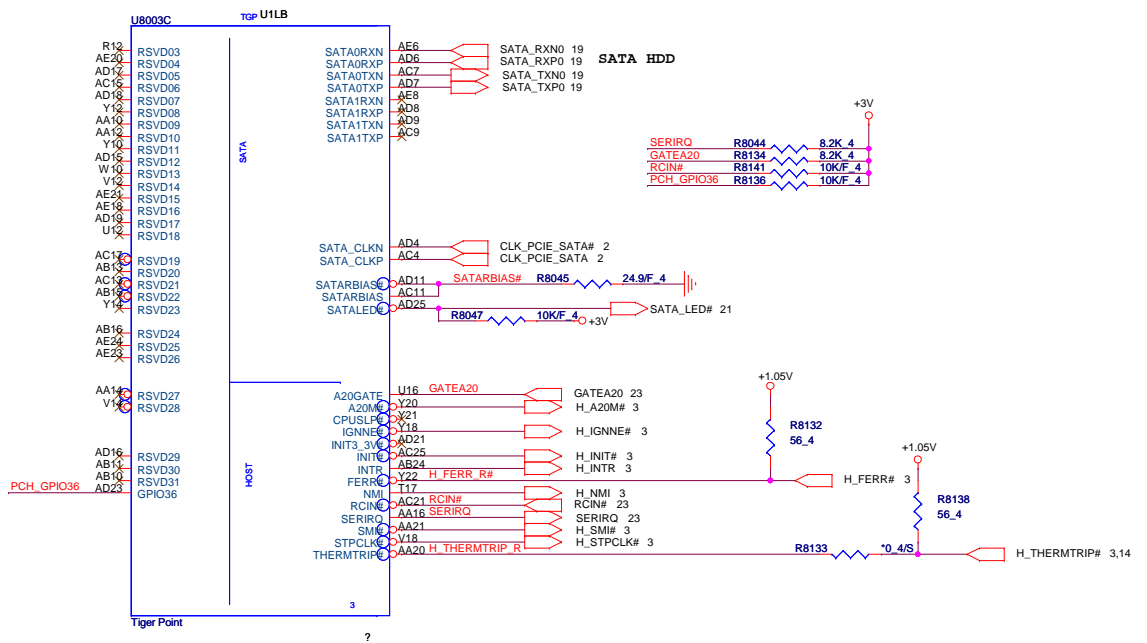

Quanta Computer Inc.
PROJECT : Annika

Size	Document Number	Rev
	TigerPoint Sata/Host(2/6)	1A
Date:	Thursday, October 29, 2009	Sheet 7 of 32

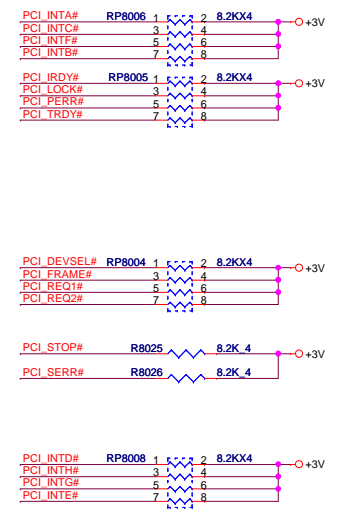
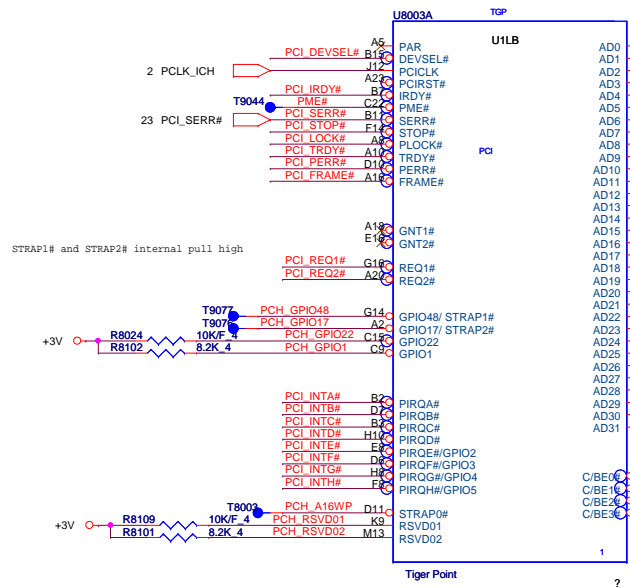

ICH Boot BIOS select

PCH_GPIO17 (INT PU)	PCH_GPIO48 (INT PU)	Boot BIOS Location
0	1	SPI
1	0	PCI
1	1	IPC (Default)

A16 SWAP Override strap

PCH_A16WP (INT PU)	Low = A16 swap override enabled High = Default
--------------------	---

IRQ	Description
PIRQA	USB UHCI Controller #1, #4
PIRQB	AC'97 Codec; option for SMBUS
PIRQC	USB UHCI Controller #3; SATA/IDE Native Mode
PIRQD	USB UHCI Controller #2
PIRQE	Internal LAN; Option for SCI, TCO, HPET#0,1,2
PIRQF	Option for SCI, TCO, HPET#0,1,2
PIRQG	Option for SCI, TCO, HPET#0,1,2
PIRQH	USB EHCI Controller; Option for SCI, TCO, HPET#0,1,2
PCI_GNT#2	Internal PU Should not be PD

Quanta Computer Inc.
PROJECT : Annika

Size	Document Number	Rev
	TigerPoint PCI(3/6)	1A
Date:	Thursday, October 29, 2009	Sheet 8 of 32

14,16,20,21,22,23,24,26,27,30 +3VPCU
 2,3,5,7,8,10,11,12,13,14,15,16,17,18,19,20,21,22,30 +3V
 6,10,30 +3V_S5

integrated pull-up of 18k - 42k .check list 0.7

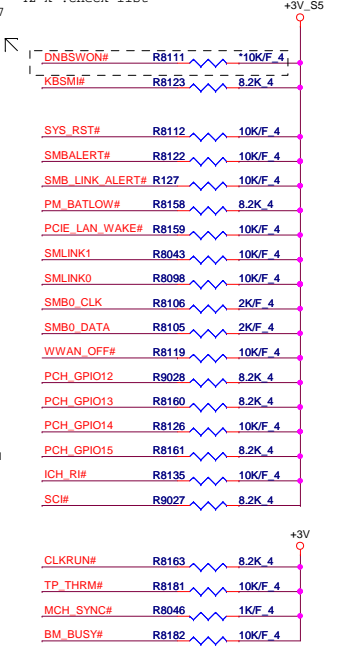
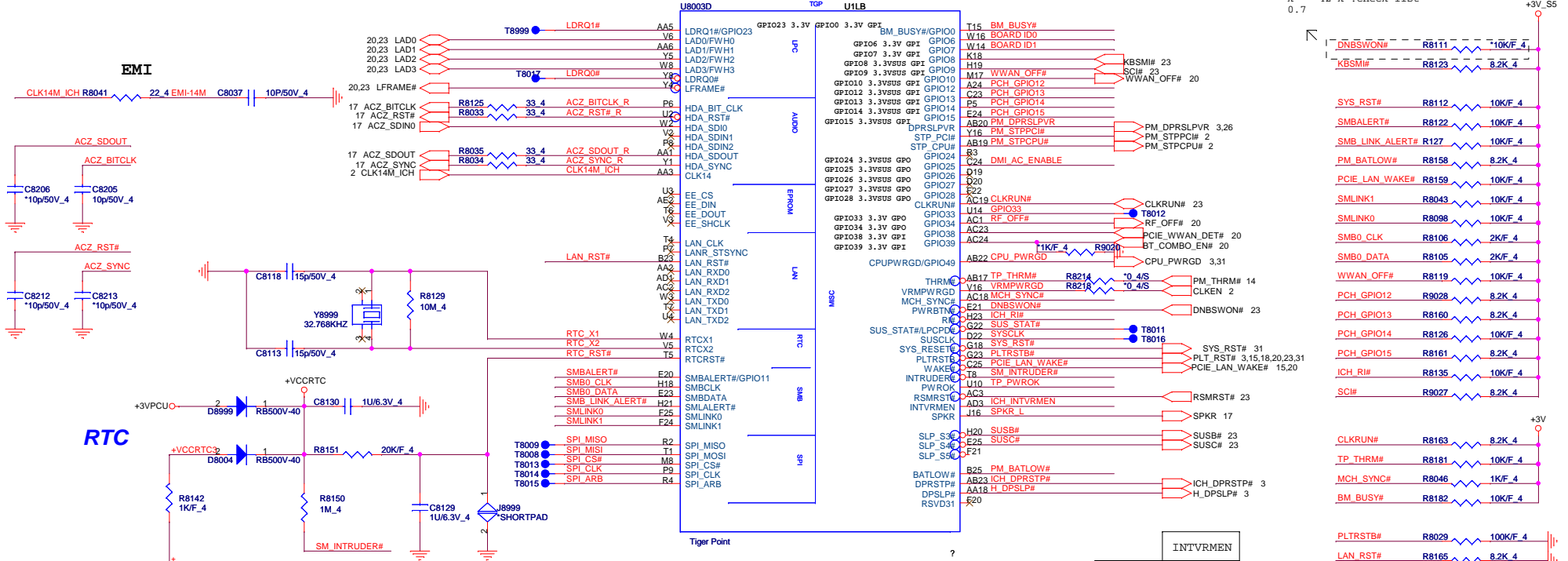

	INTVRMEN
Enable (default)	1
Disable	0

Board ID	ID1	ID0
WO decoder WO SIM	0	0
WO decoder W/ SIM	0	1
W/ decoder WO SIM	1	0
W/ decoder W/ SIM	1	1

GPIO25 This signal has a weak internal pull-up. If the signal is sampled high, the DMI interface is strapped to operate in DC coupled mode (No coupling capacitors are required on DMI differential pairs). If the signal is sampled low, the DMI interface is strapped to operate in AC coupled mode (Coupling capacitors are required on DMI differential pairs). NOTE: Board designer must ensure that DMI implementation matches the strap selection.

ACZ_SDOUT (INT PD)	ACZ_SYNC (INT PD)	Description
0	0	* 4 x 1s
1	0	Reserved
0	1	Reserved
1	1	1 x 4s (1 port/4 lanes)

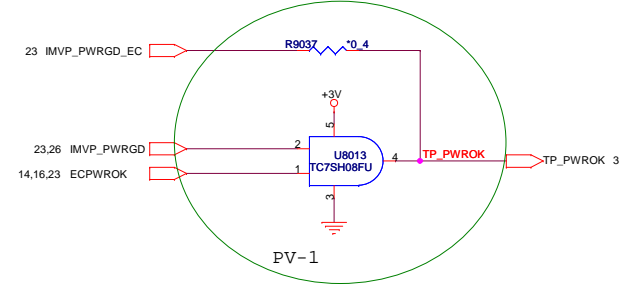

Quanta Computer Inc.
PROJECT : Annika

Size Document Number
TigerPoint GPIO(4/6) Rev 1A

Date: Thursday, October 29, 2009 Sheet 9 of 32

- 2,3,5,7,8,9,11,12,13,14,15,16,17,18,19,20,21,22,30 +3V
- 12,16,17,19,20,22,30 +5V
- 5,6,20,30 +1.5V
- 2,3,5,7,14,26,29,31 +1.05V
- 6,9,30 +3V_S5
- 30 +5V_S5

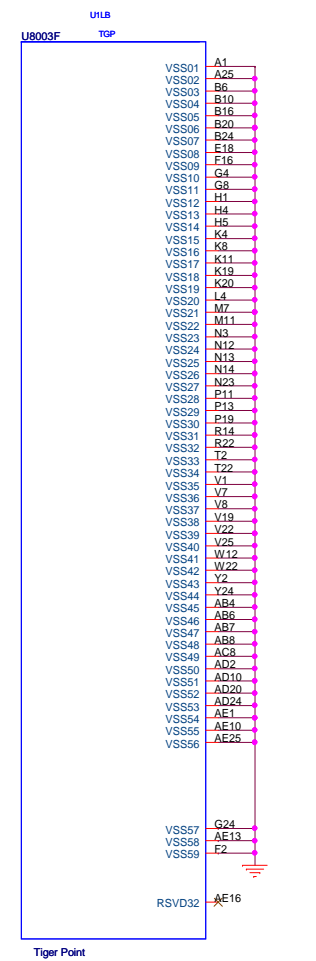
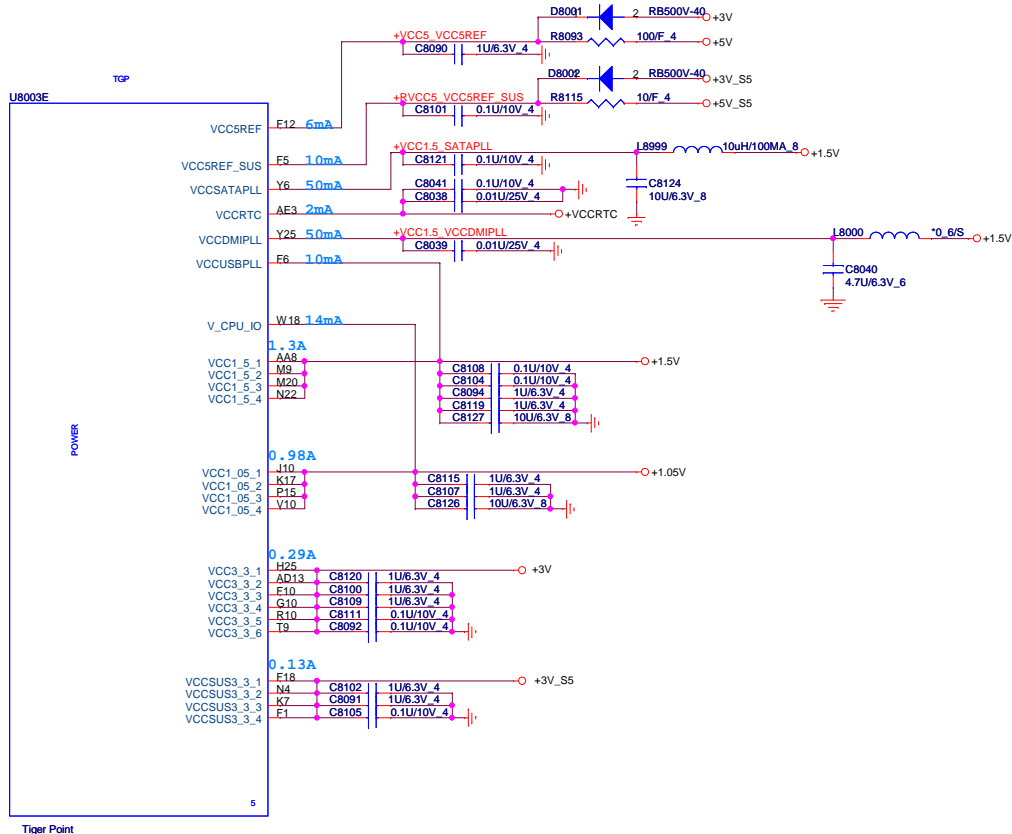

Tiger Point
?

Tiger Point

Quanta Computer Inc.
PROJECT : Annika

Size	Document Number	Rev
	TigerPoint Power(5/6)	1A
Date:	Thursday, October 29, 2009	Sheet 10 of 32

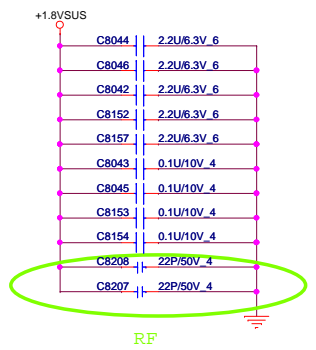
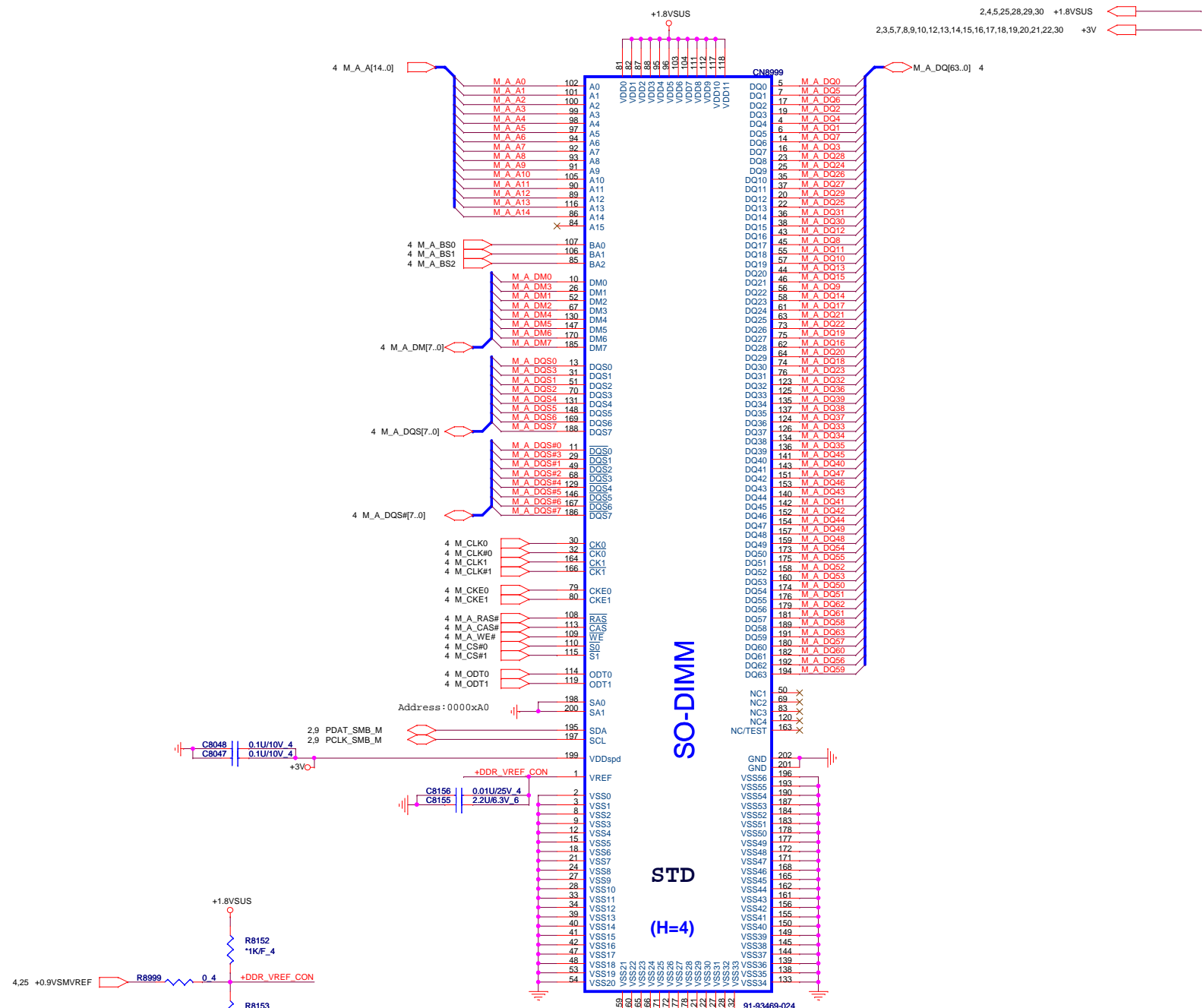

Quanta Computer Inc.
PROJECT : Annika

Size	Document Number DDR2 SODIMM	Rev 1A
Date	Thursday, October 29, 2009	Sheet 11 of 32

2,3,5,7,8,9,10,11,13,14,15,16,17,18,19,20,21,22,30 +3V
2,3,5,7,10,14,26,29,31 +1.05V

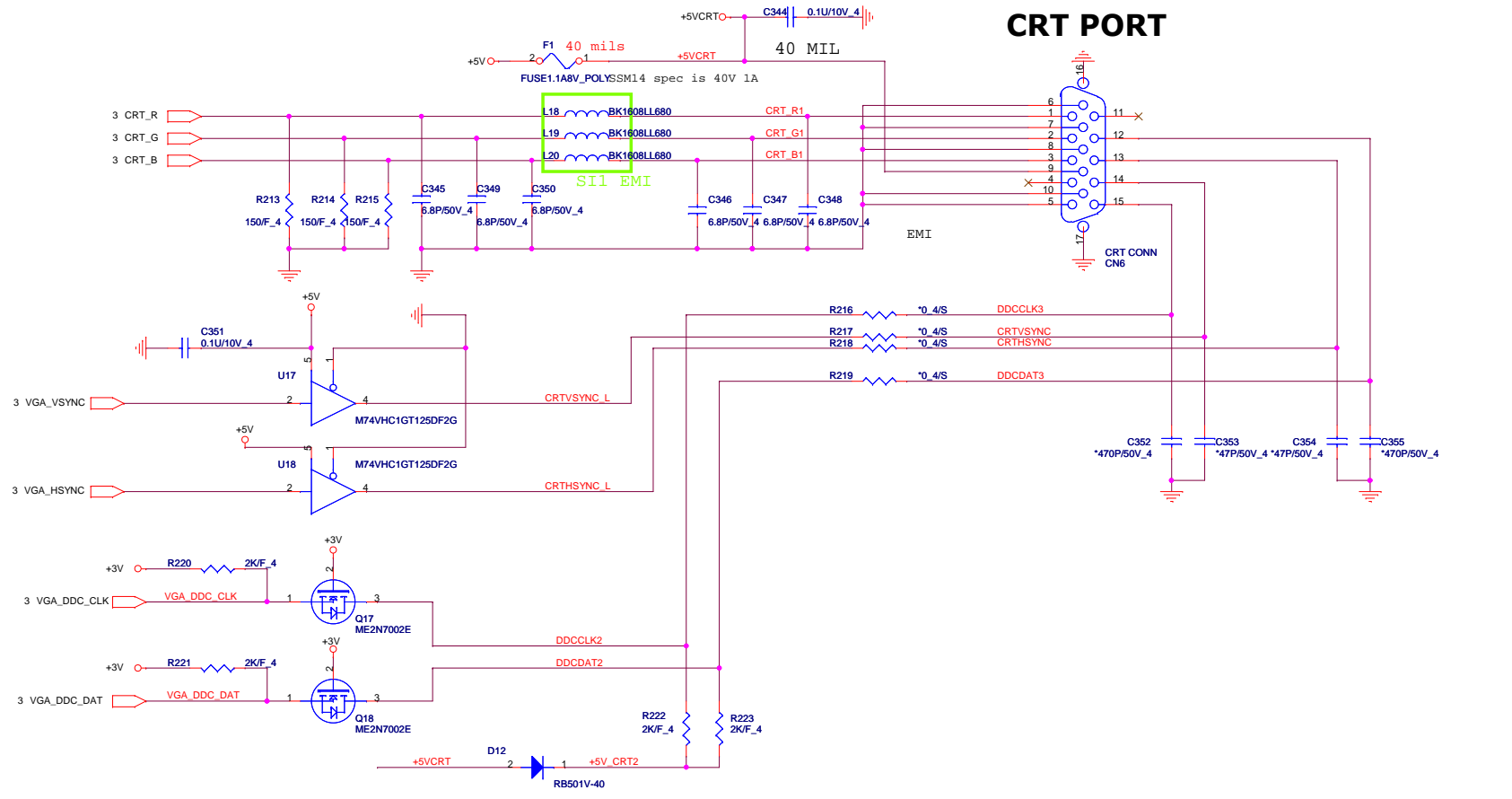

CRT PORT

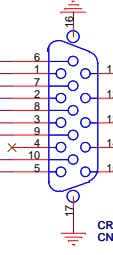

Quanta Computer Inc.
PROJECT : Annika

Size	Document Number	Rev
	CRT	1A
Date:	Thursday, October 29, 2009	Sheet 12 of 32

Note:

SD/MMC	MS	XD
SP0		XD_CD#
SP1	SD_WP	XD_CD#
SP2	SD_WP	
SP3	SD_CD#	
SP4	SD_DAT1	XD_D4
SP5	MS_BS	XD_D5
SP6	MS_D1	XD_D3
SP7	SD_DAT0	MS_D0
SP8	SD_DAT7	MS_D2
SP9	MS_INS#	
SP10	SD_DAT6	MS_D3
SP11	SD_CLK	MS_SCLK
SP12	SD_DAT5	XD_D0
SP13	SD_DAT4	XD_WP#
SP14	SD_DAT3	XD_RE#
SP15	SD_DAT3	XD_WE#
SP16	SD_DAT2	XD_RE#
SP17		XD_ALE
SP18		XD_CE#
SP19		XD_CLE

PU for internal CLK input
Unstuff for external XTAL(12MHZ)

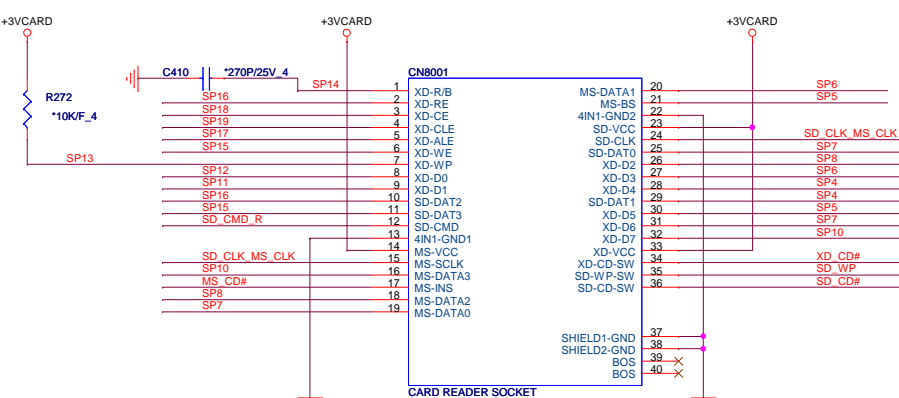
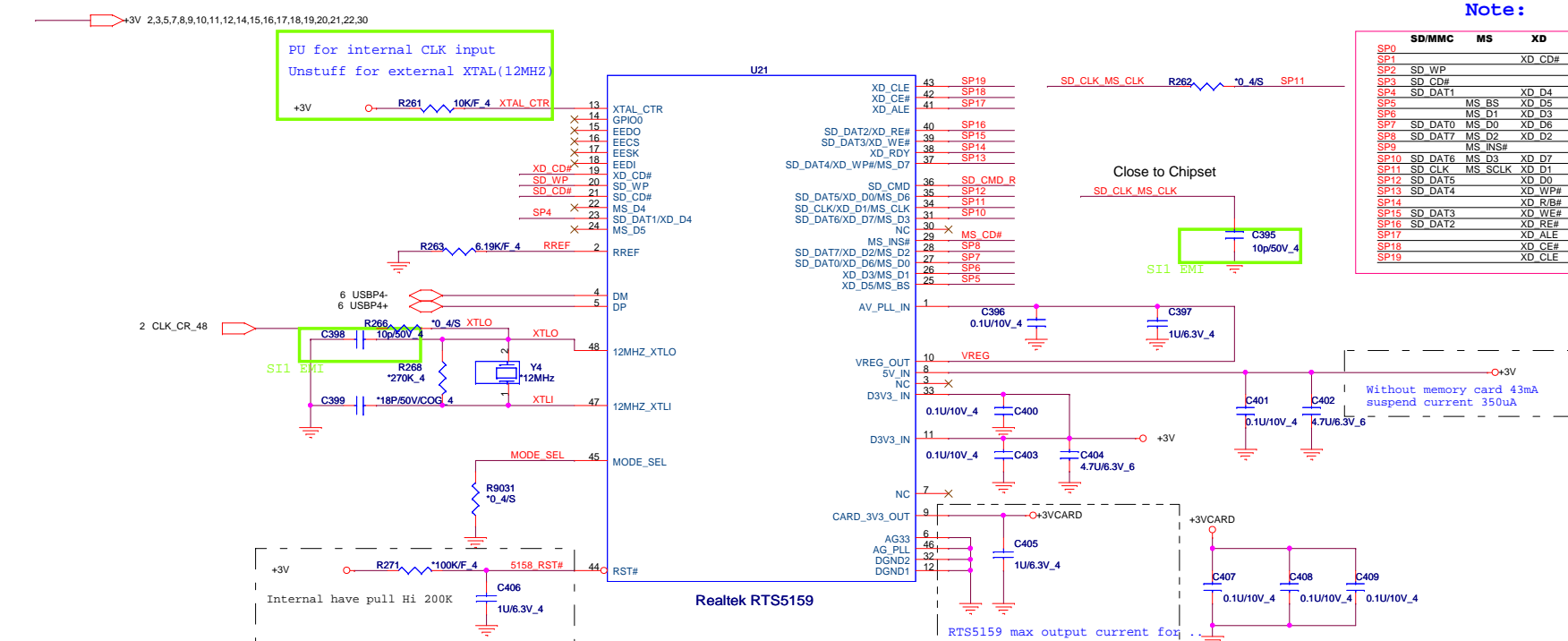

5 IN1 CARD-READER (PUSH-PUSH)
Support SD/SD PRO/MMC/MS/MS PRO/xD Cards

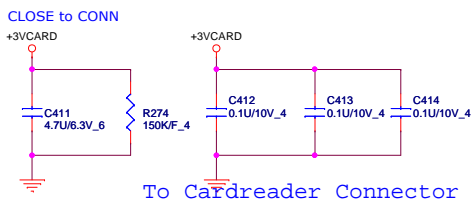

To Cardreader Connector

Quanta Computer Inc.
PROJECT : Annika

Size	Document Number	Rev
	Realtek RTS5159 & Card Reader	1A
Date:	Thursday, October 29, 2009	Sheet 13 of 32

LID Switch

- +3VPCU 9,16,20,21,22,23,24,26,27,30
- +3V 2,3,5,7,8,9,10,11,12,13,15,16,17,18,19,20,21,22,30
- +1.05V 2,3,5,7,10,26,29,31

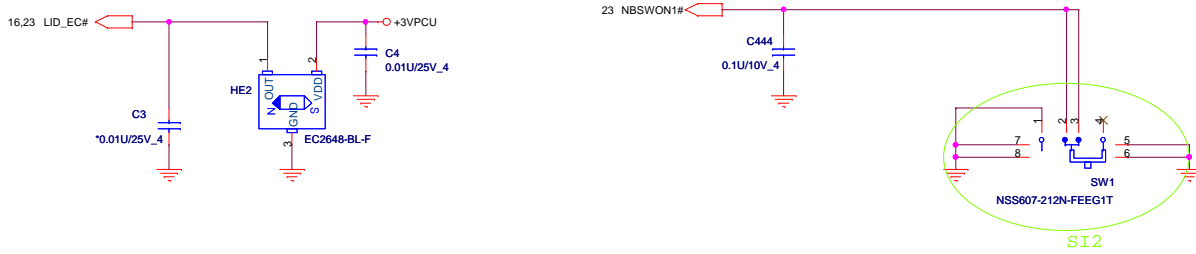

CPU Thermal

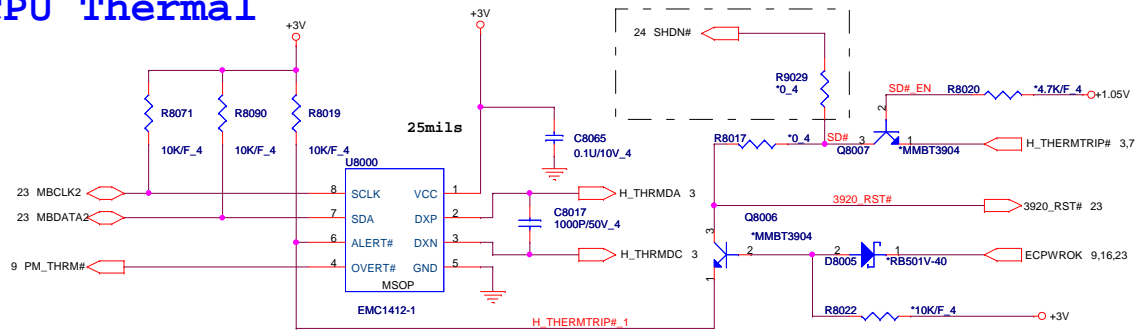

1. Level 1 Environment-related Substances Should NEVER be Used.
2. Purchase ink, paint, wire rods, and Molding resins only from the business Partners that Sony approves as Green Partners.

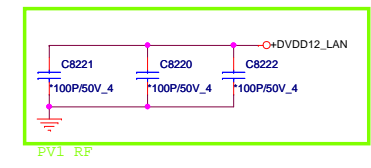
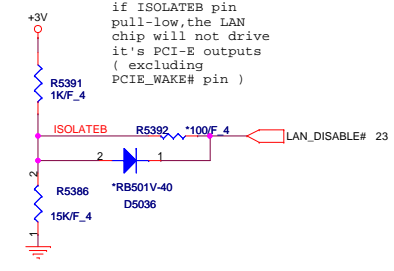
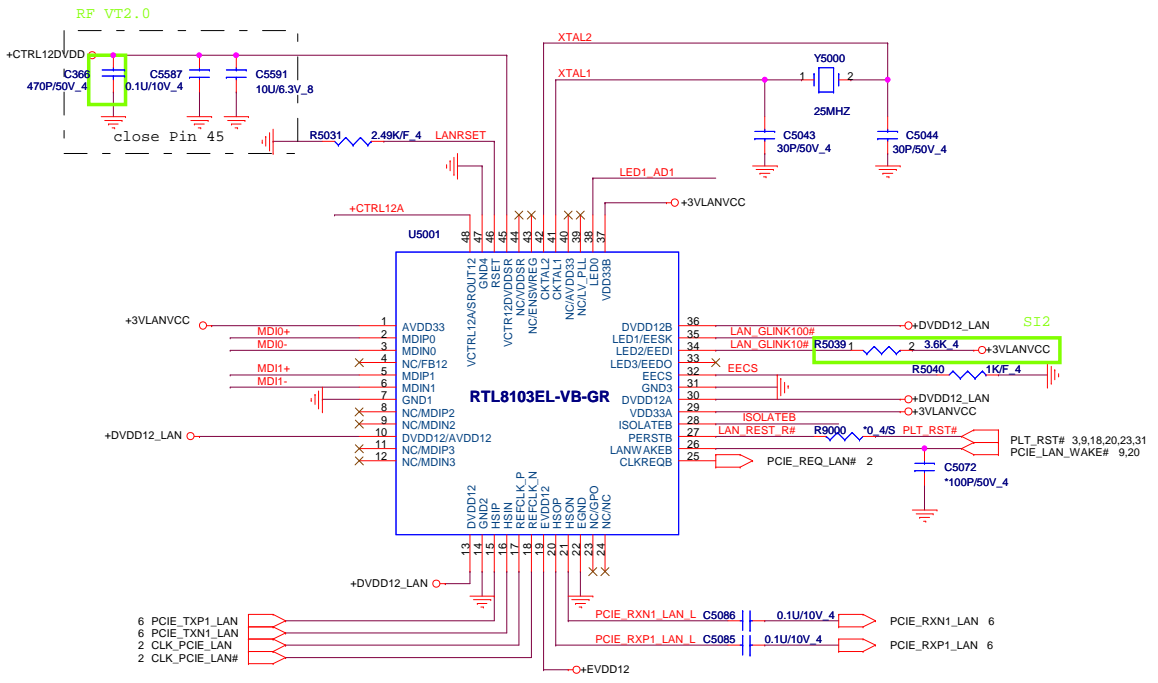
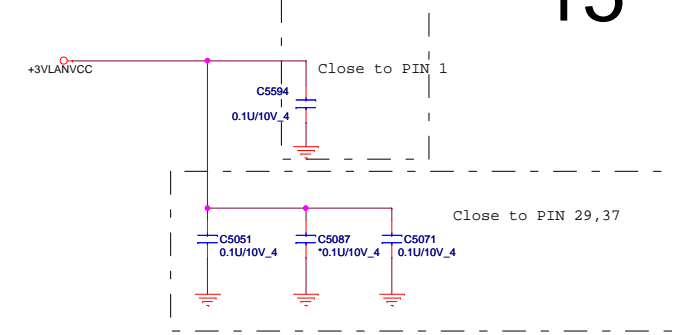
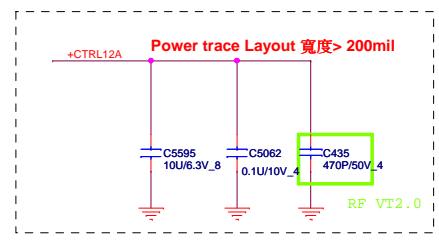
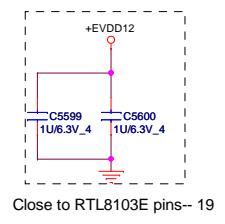
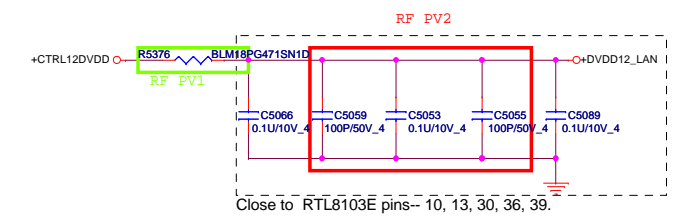

Symbol	Type	Pin No (64-Pin)	Pin No (48-Pin)	Description
LED0	O	57	38	LED0: 00 01 10 11
LED1	O	56	35	LED1: Tx/Rx Tx/Rx Tx Tx
LED2	O	55	34	LED2: LINK100 LINK LINK LINK100
LED3	O	54	33	LED3: LINK10 FULL Rx LINK10

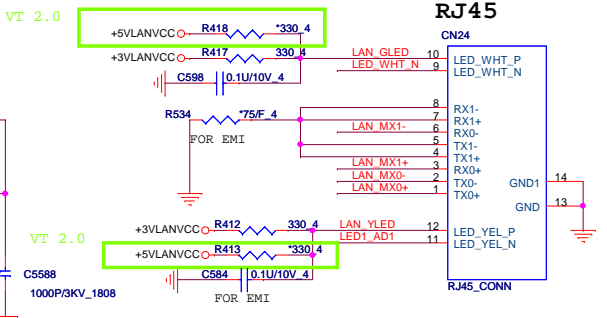
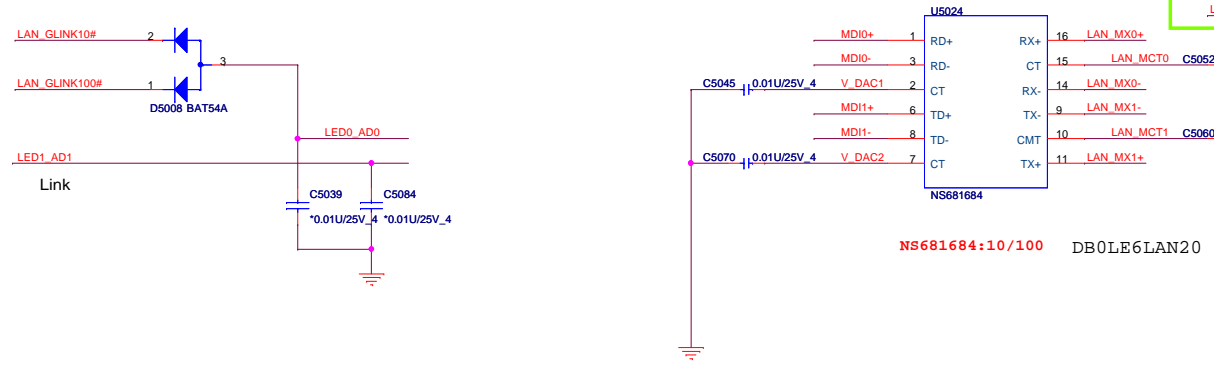
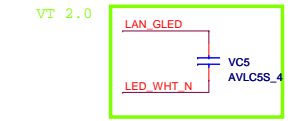
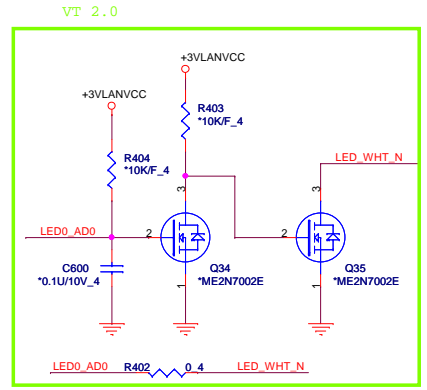

Quanta Computer Inc.
PROJECT : Annika

Size: Document Number: **RTL111DL/8103E RJ45** Rev: 1A
 Date: Thursday, October 29, 2009 Sheet: 15 of 32

- 2,3,5,7,8,9,10,11,12,13,14,15,17,18,19,20,21,22,30 +3V
- 9,14,20,21,22,23,24,26,27,30 +3VPCU
- 10,12,17,19,20,22,30 +5V
- 24,25,26,27,28,29,30 +VIN

LED Panel(LDS)

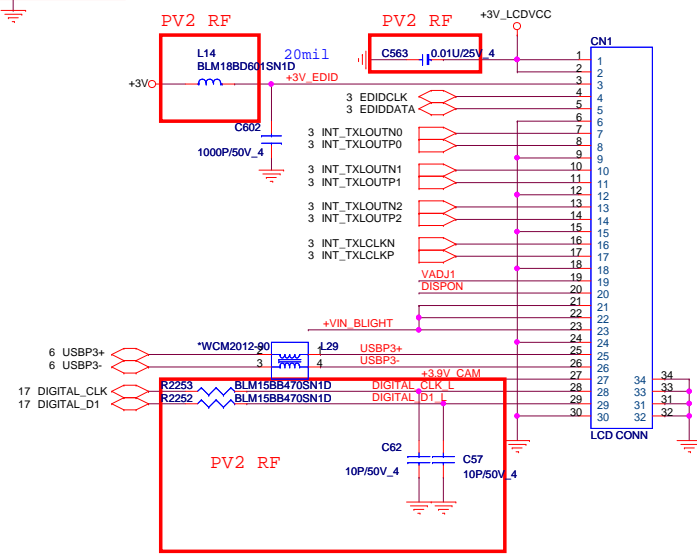

Backlight Control(LDS)

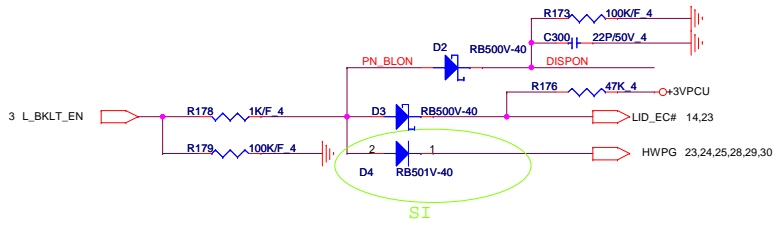

LCD POWER SWITCH

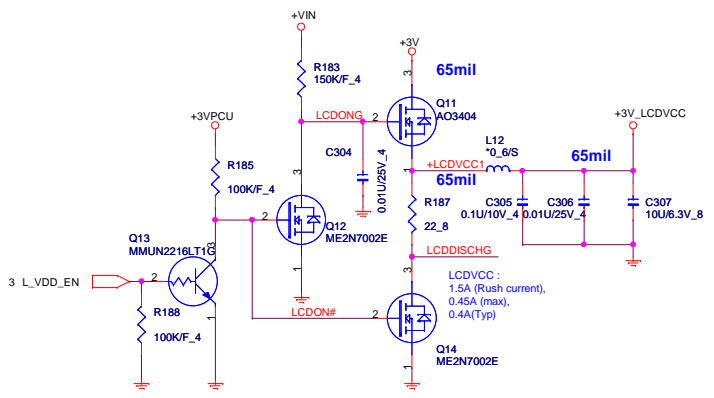

CAMERA POWER

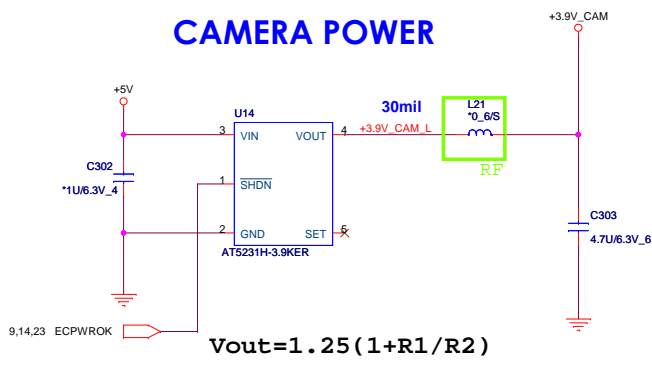

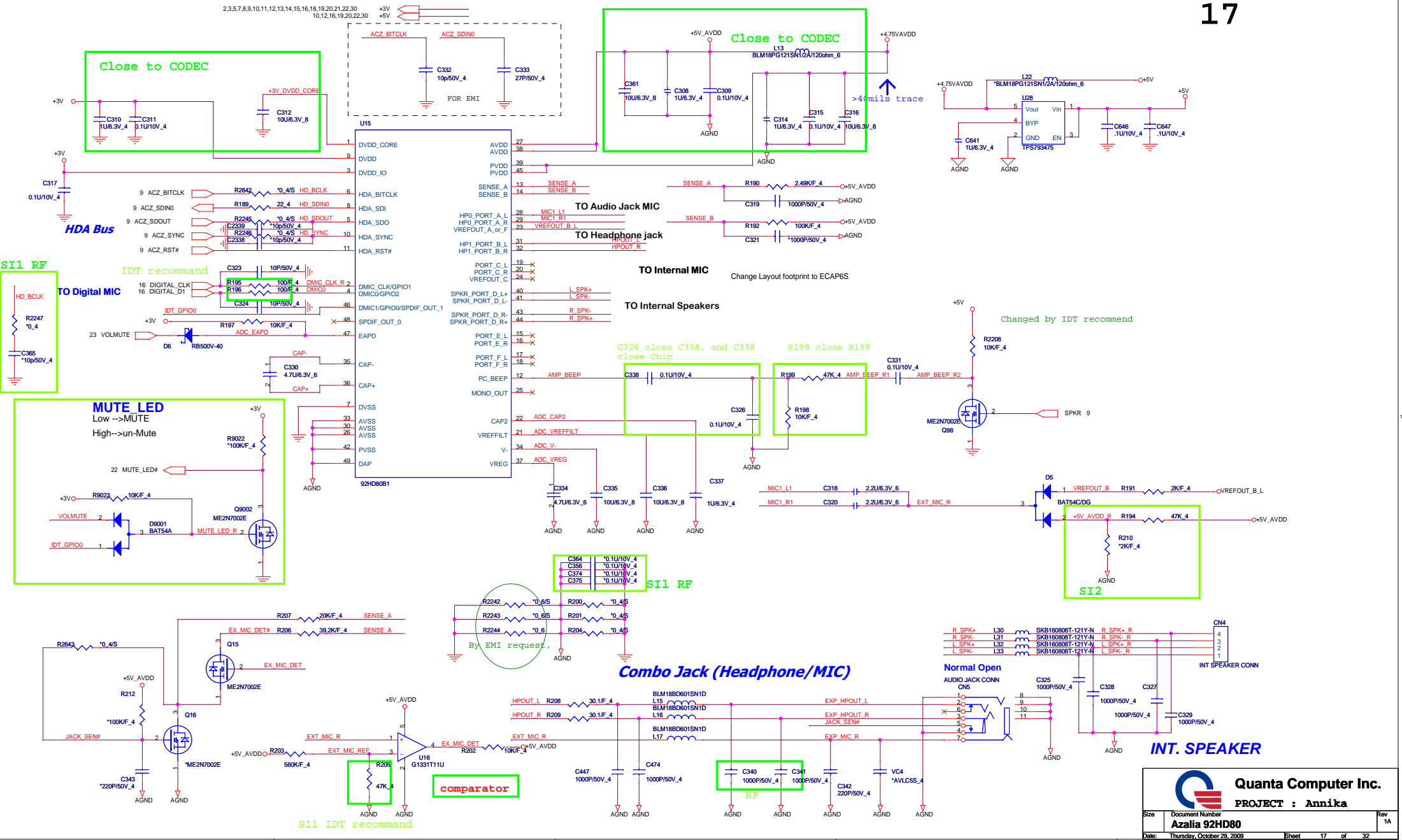

Quanta Computer Inc.
PROJECT : Annika

Size	Document Number	Rev
	Azalia 92HD80	1A
Date:	Thursday, October 29, 2009	Sheet 17 of 32

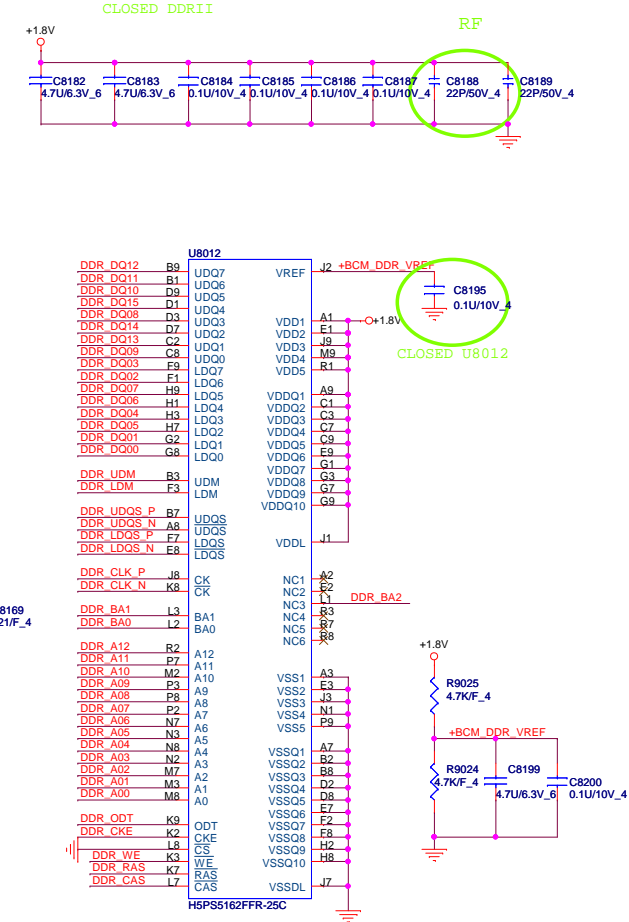
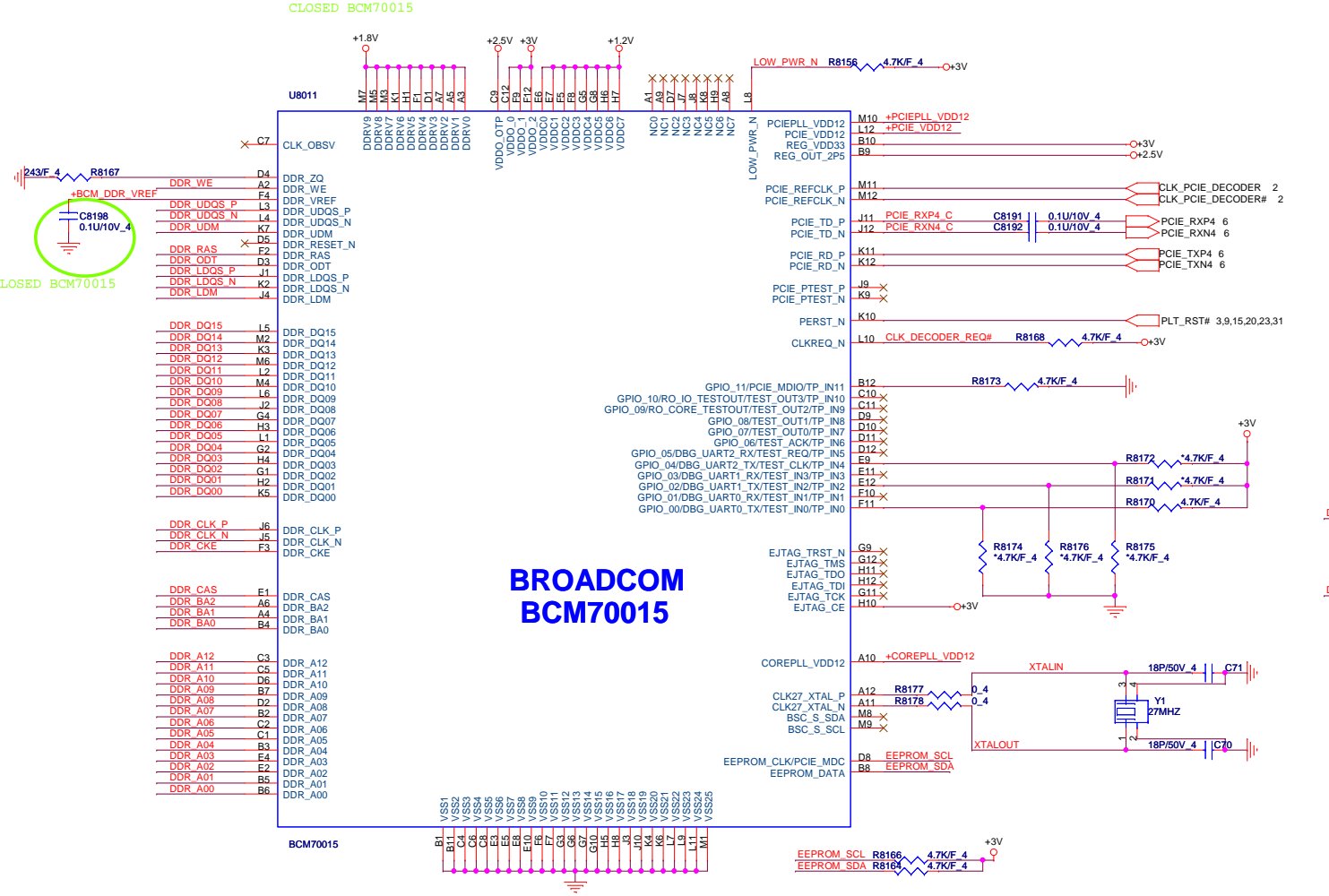
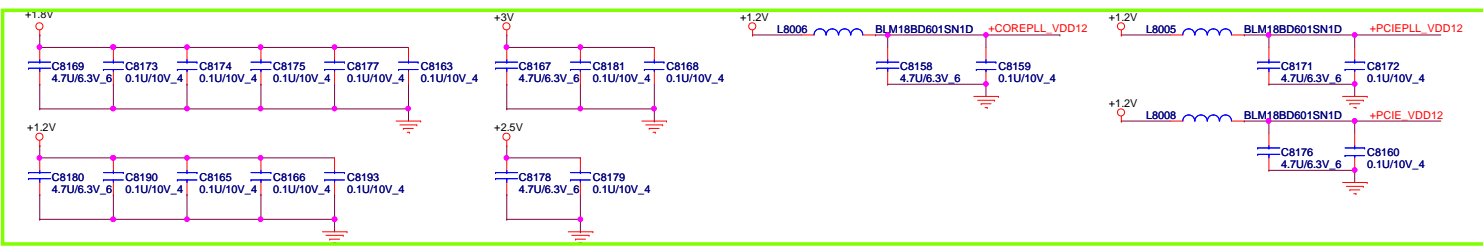

BROADCOM BCM70015

DDR2 RAM Configuration Table

DESCRIPTION	Vendor	Vendor P/N	QCI P/N
DDR2 32Mx16, 128bit 400MHZ (-25)	HYNIX	H5PS5162FFR-25C	AKD5FG-TW03
DDR2 32Mx16, 128bit 400MHZ (-25)	SAMSUNG	K4N51163QG-HC25	AKD5FG-T501

Quanta Computer Inc.
PROJECT : Annika

2.5" SATA HDD OR SSD(TOSHIBA)

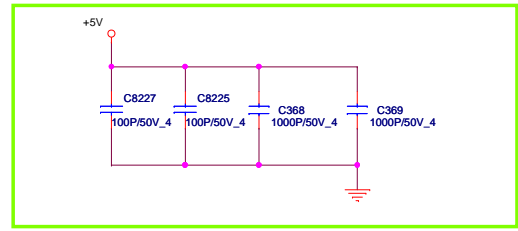
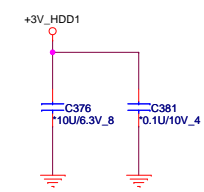
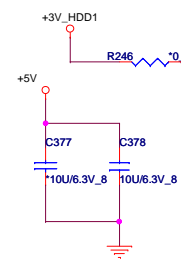
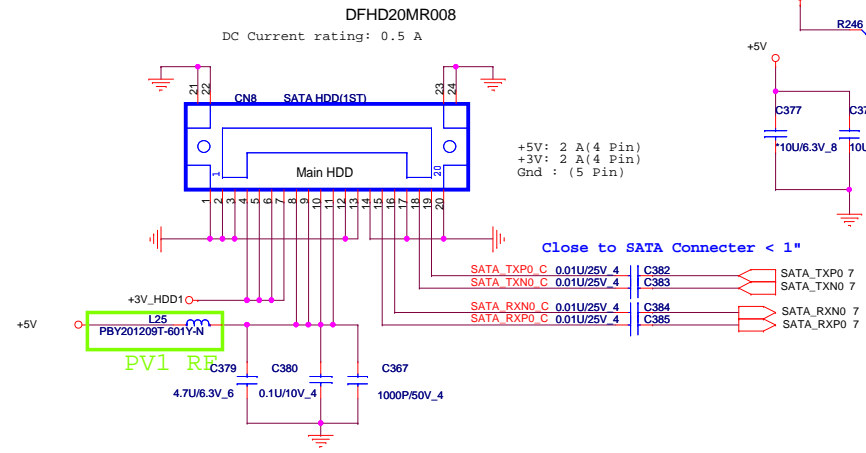

PVI RF

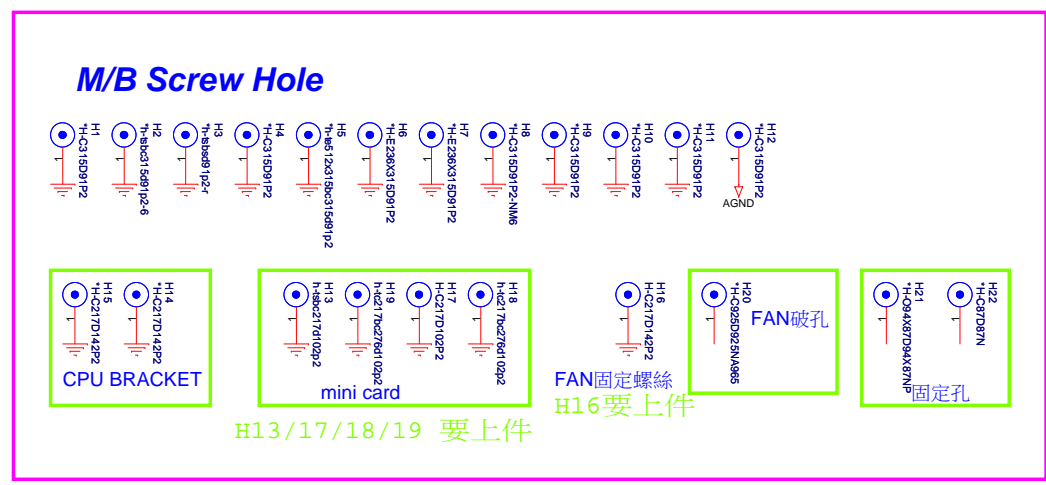

EMI spring

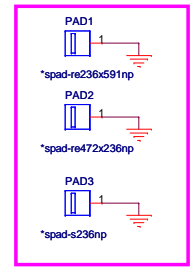

Quanta Computer Inc.
PROJECT : Annika

Size	Document Number	Rev
	SATA HDD/SCREW HOLE	1A
Date:	Thursday, October 29, 2009	Sheet 19 of 32

- +3VPCU 9,14,16,21,22,23,24,26,27,30
- +1.5V 5,6,10,30
- +3V 2,3,5,7,8,9,10,11,12,13,14,15,16,17,18,19,21,22,30
- +5V 10,12,16,17,19,22,30

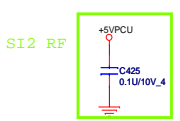
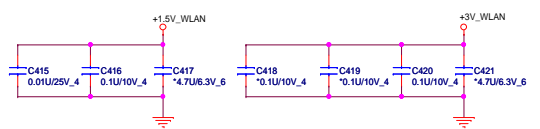
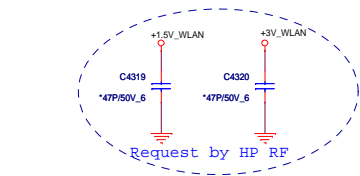

Mini PCI-E Card 1 Half Mini PCI-E WLAN

The value of the capacitor is suggest by Siemens HQ expert.
For against 900MHz RF interference. The value of capacitor is 27pF.
For against 1800MHz RF interference. The value of capacitor is 10pF.
1nF/10nF value capacitor use for against ESD purpose.

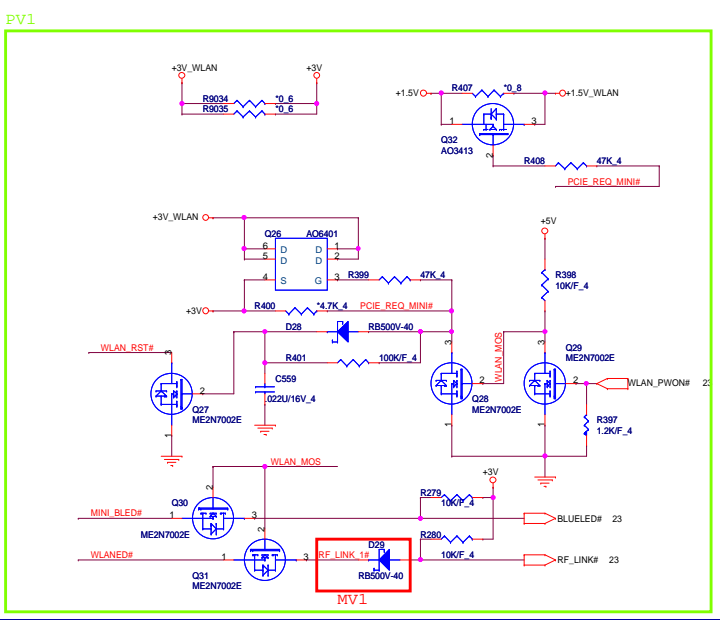
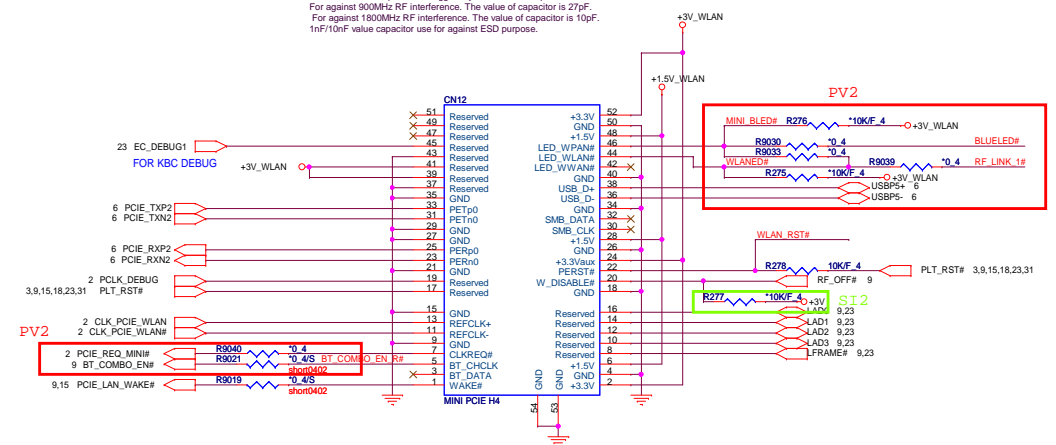

Full mini PCI-E for WWAN Mini PCI-E Card 2

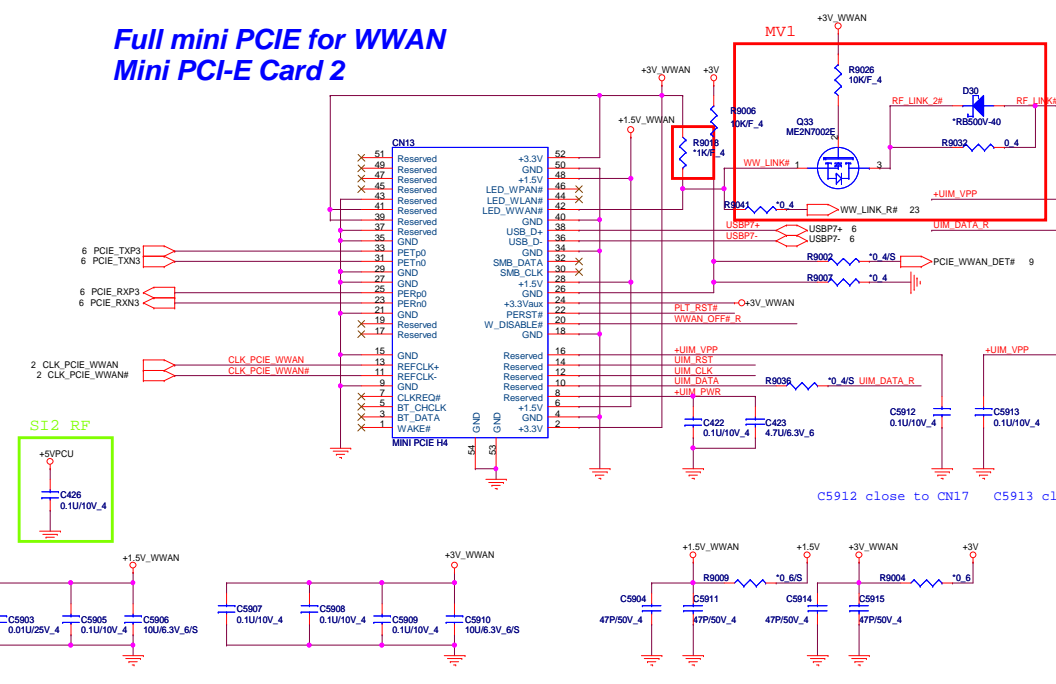

SIM CARD SIGNALS ROUTE PARALLEL

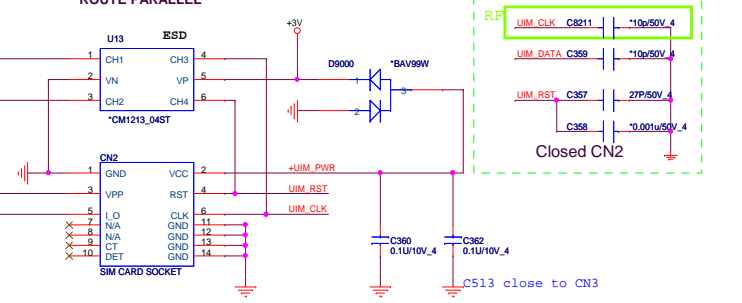

SIM CARD

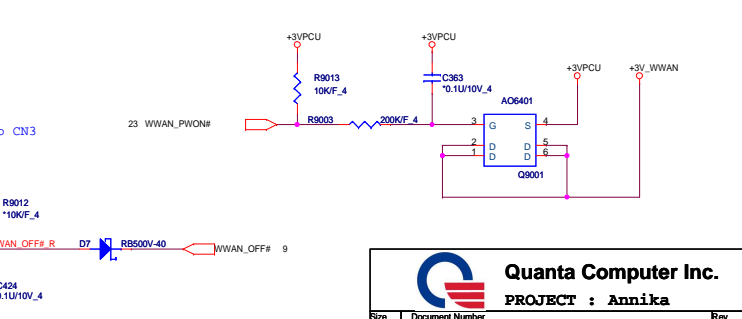

1x Left side USB port supports Keyed USB.

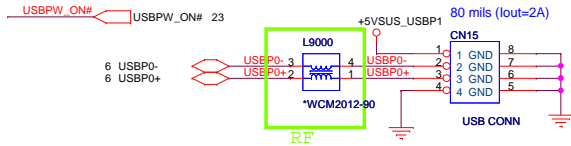
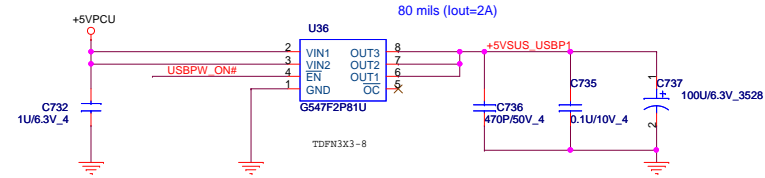

PWR Button/LED

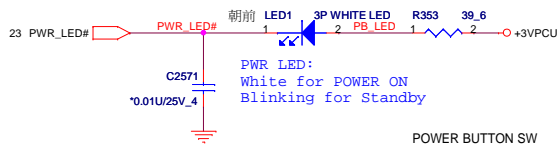

SATA/LED

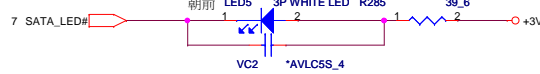

Charging & Discharging/LED

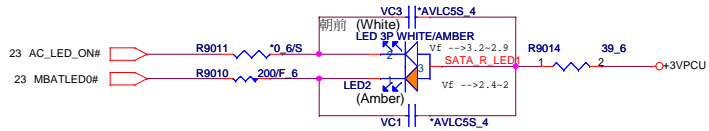

For Right 2xUSB Ports PWR

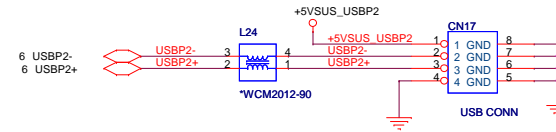
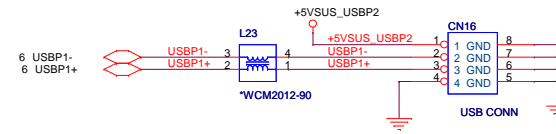
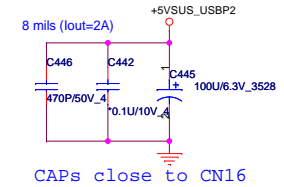
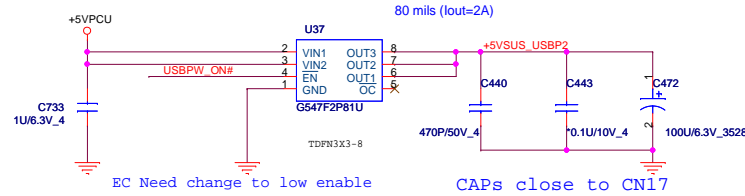

Keyboard (KBC)

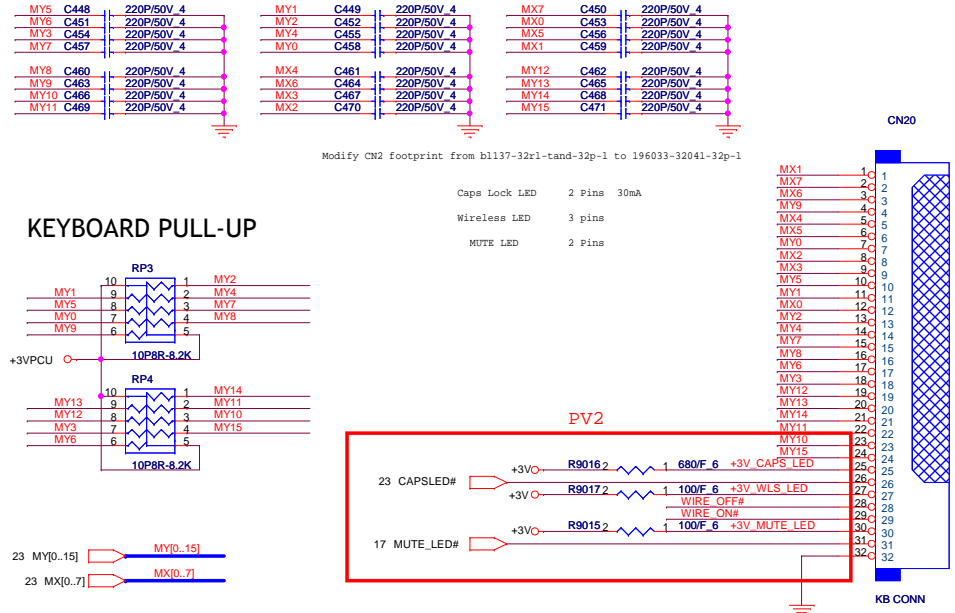

KEYBOARD PULL-UP

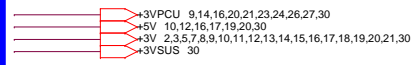
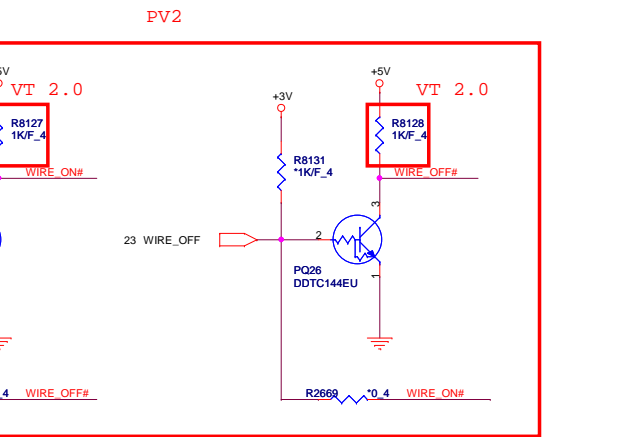
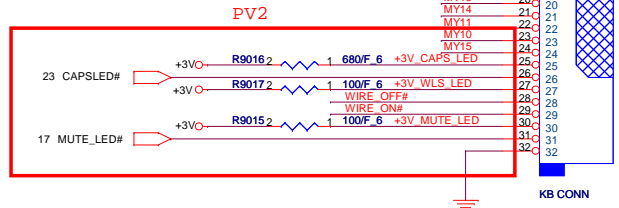
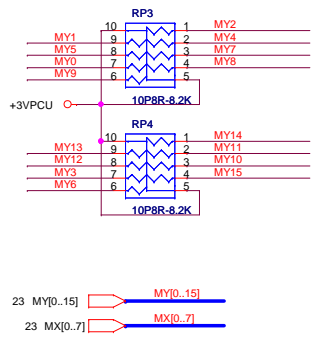

TOUCH PAD CONNECTOR

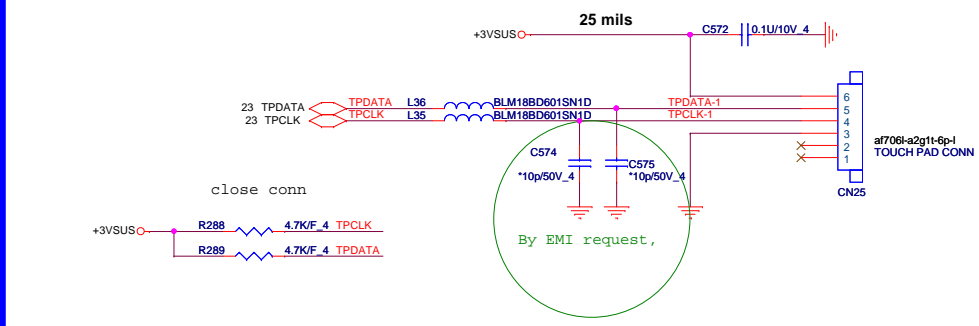

TOUCH SCREEN

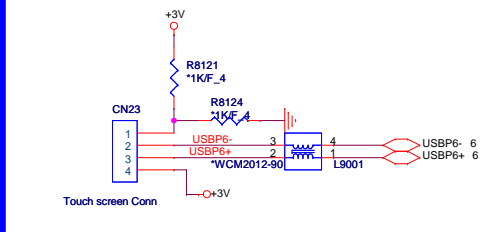

CPU FAN

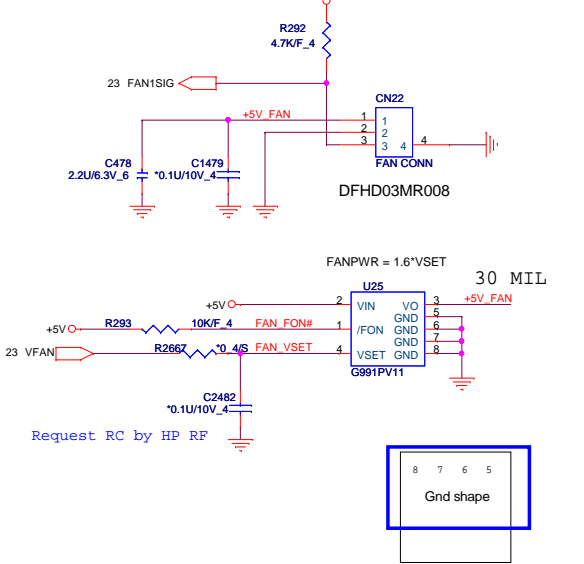

Quanta Computer Inc.
 PROJECT : Annika

Size	Document Number	Rev
	KB/TP/BT/CPU FAN/TP SCREEN	1A
Date:	Thursday, October 29, 2009	Sheet 22 of 32

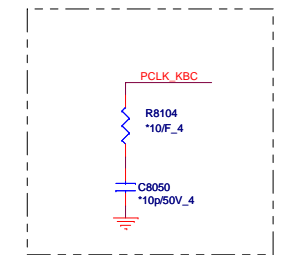
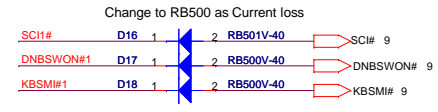
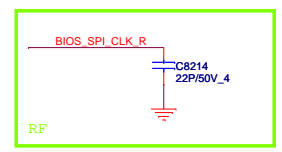
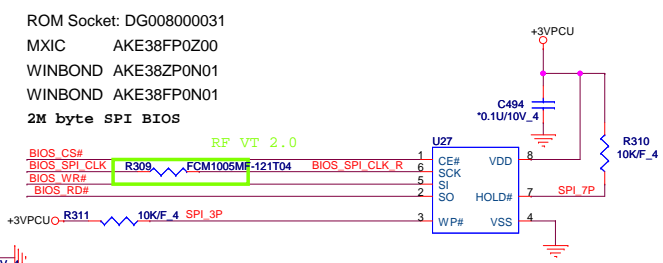
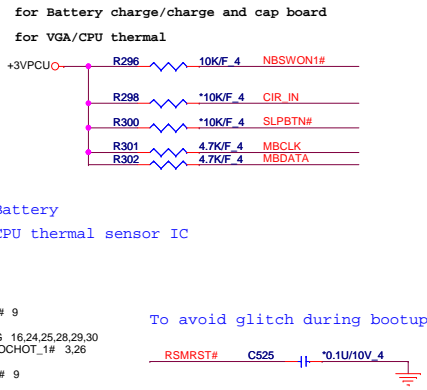
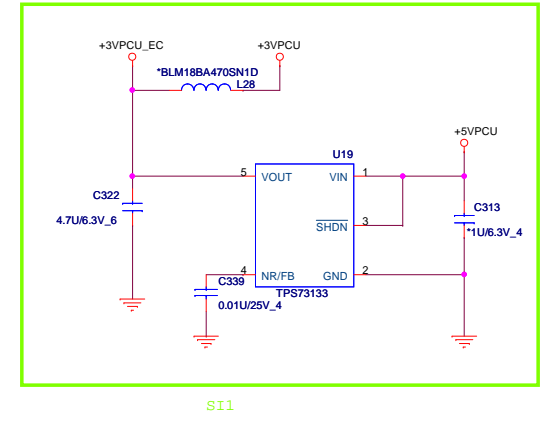
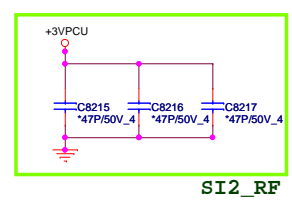
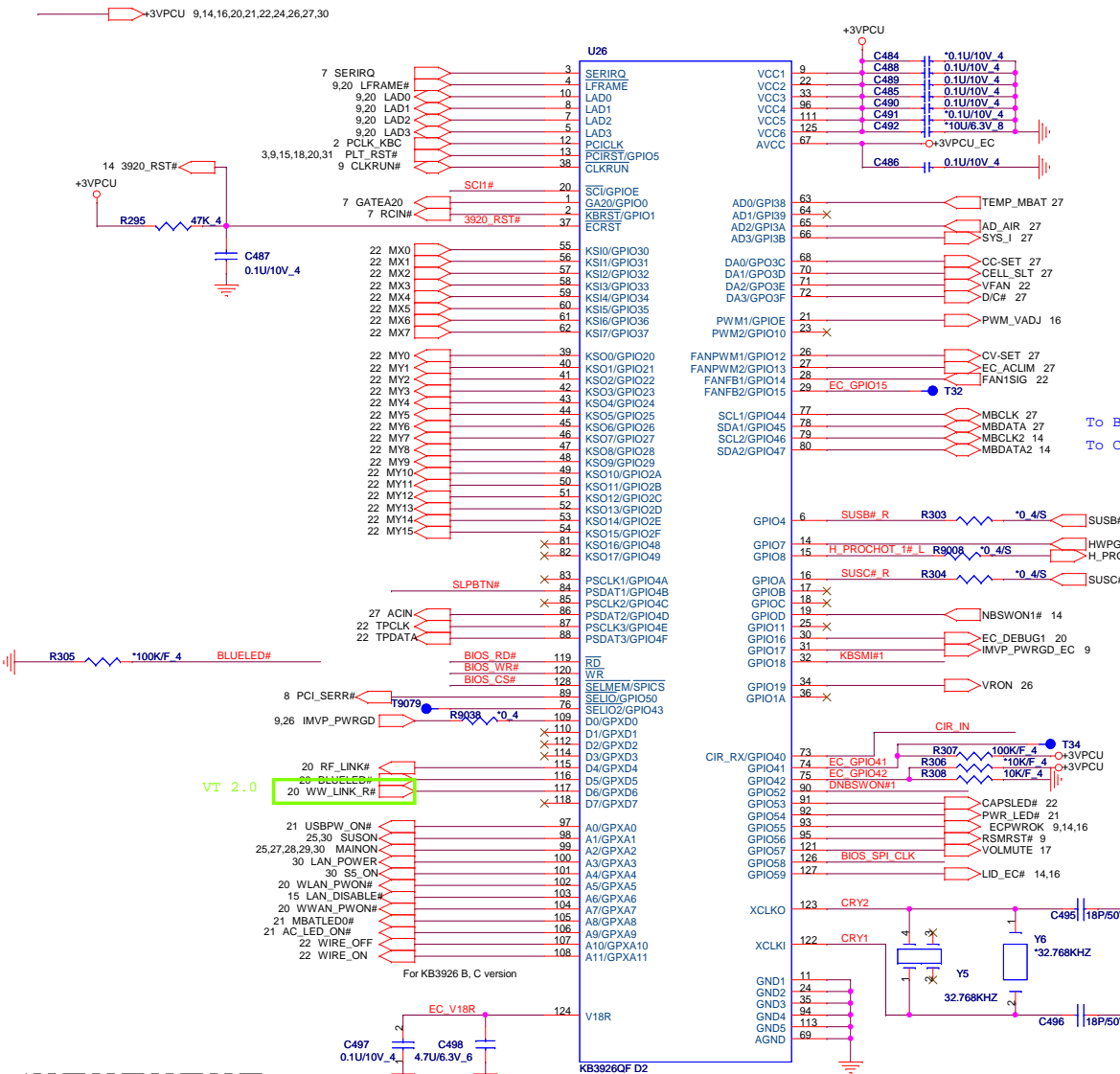

Add Pin 117,103 for DSM,116 for Bluetooth,Pin 23 for Key Beep to Amplifier
 Delete T10 and tie pin 117 from Lan for DSM

Quanta Computer Inc.
PROJECT : Annika

Size	Document Number	Rev
	KBC3926/ROM	1A
Date:	Friday, October 30, 2009	Sheet 23 of 32

DC/DC +3V_ALW/+5V_ALW/+5V_ALW2 /+15V_ALW

SI2_RF

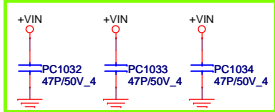

PV1_RF

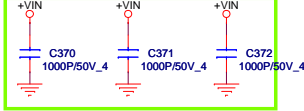

+5VPCU Volt +/- 5%
 Countinue current:4A
 Peak current:5.5A
 OCP minimum 6A

SI2_RF

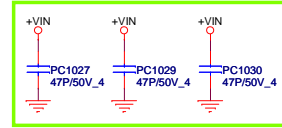

PV1_RF

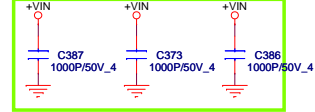

+3VPCU Volt +/- 5%
 Countinue current:4A
 Peak current:5.5A
 OCP minimum 6A

SI2_RF

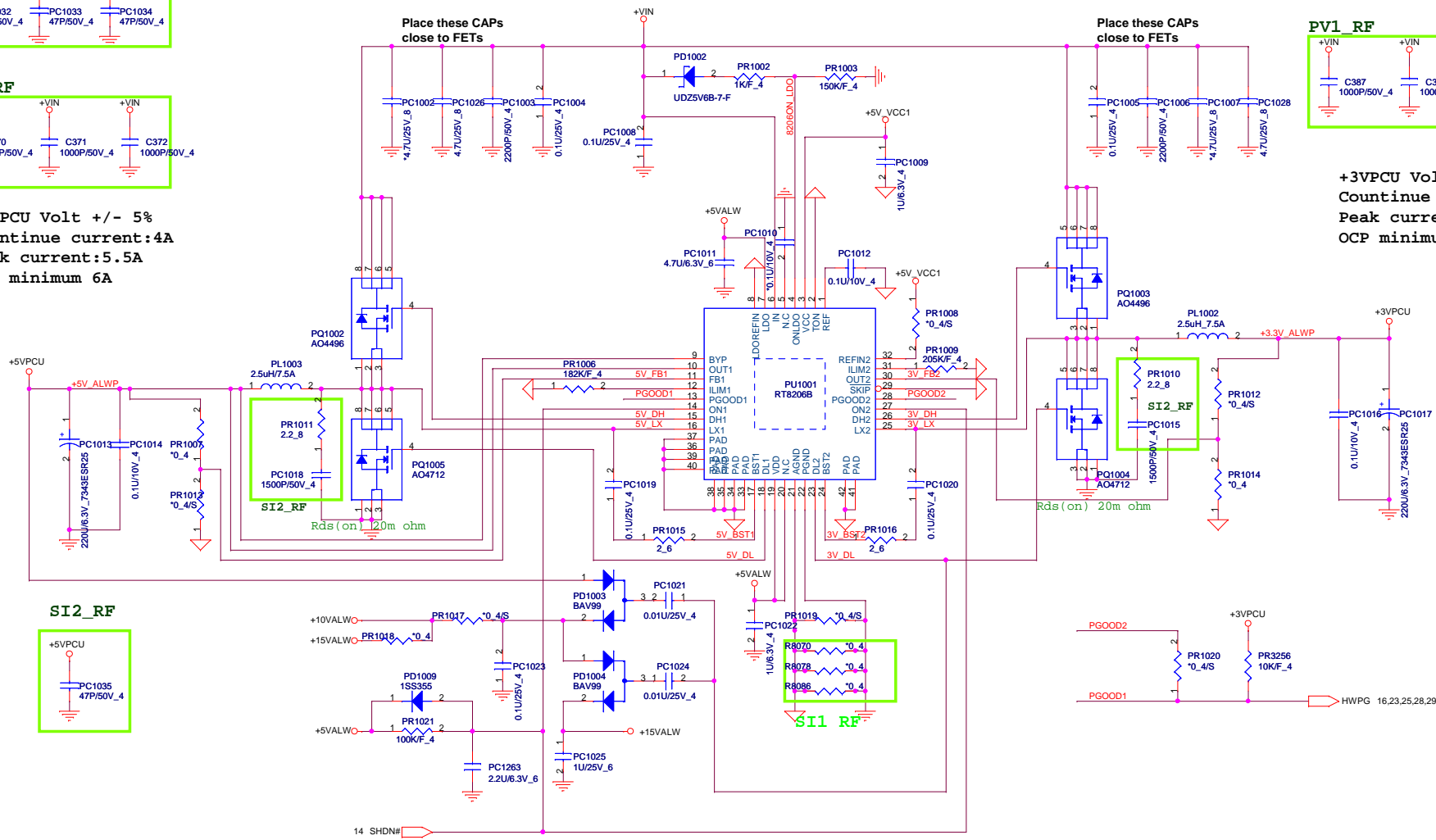
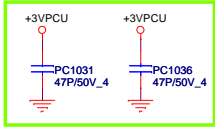

SI2_RF

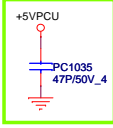

SI1_RF

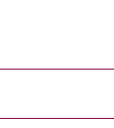

Quanta Computer Inc.
 PROJECT : Annika

Size	Document Number	Rev
	3VPCU/5VPCU(RT8206)	1A
Date:	Thursday, October 29, 2009	Sheet 24 of 32

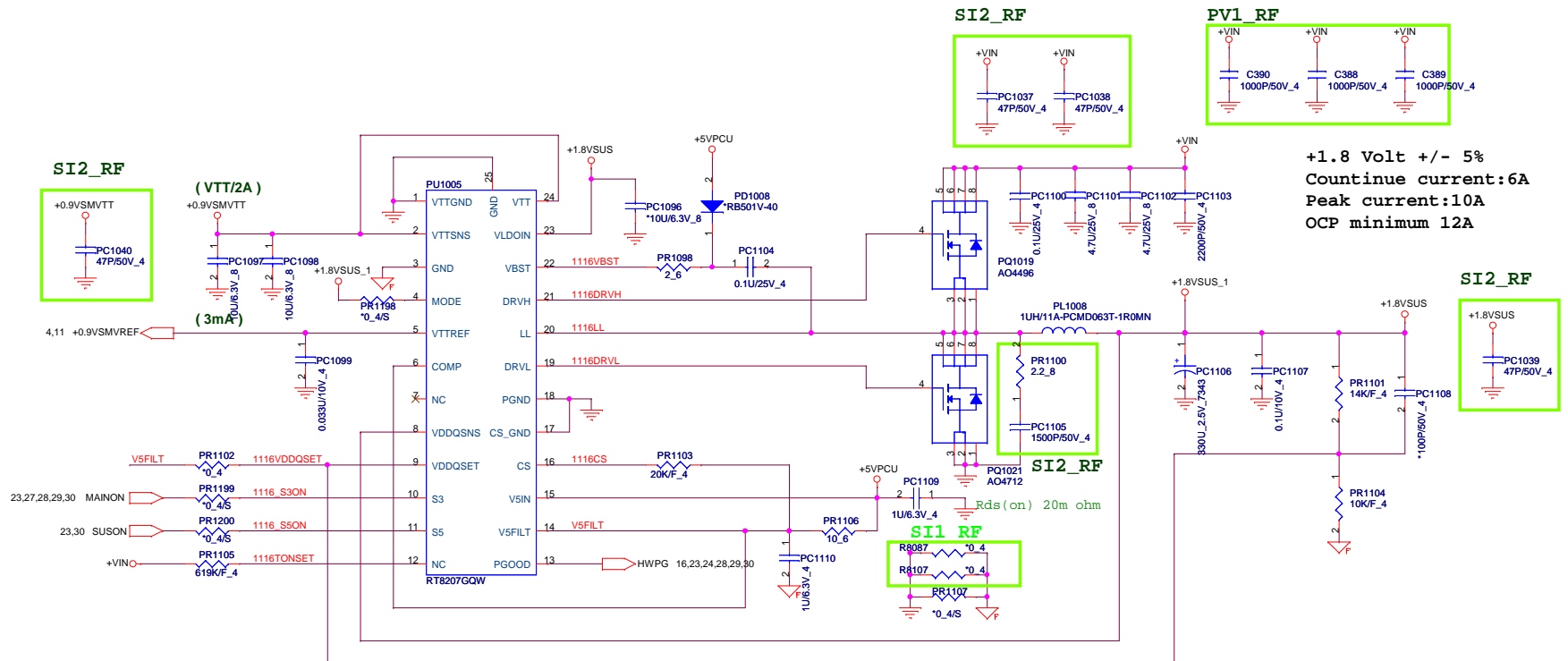

+1.8 Volt +/- 5%
Countinue current:6A
Peak current:10A
OCp minimum 12A

 Quanta Computer Inc. PROJECT : Annika		Rev
		1A
Size	Document Number	Date
	DDR2 +1.8VSUS/+0.89V	Thursday, October 29, 2009
		Sheet 25 of 32

SI1_RF

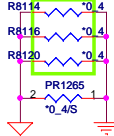

SI2_RF

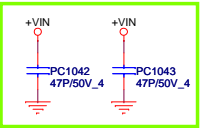

PV1_RF

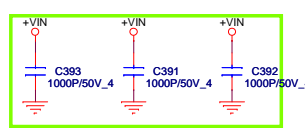

+CPUVORE Volt +/- 5%
 Countinue current:3A
 Peak current:4A
 OCP minimum:5A

SI2_RF

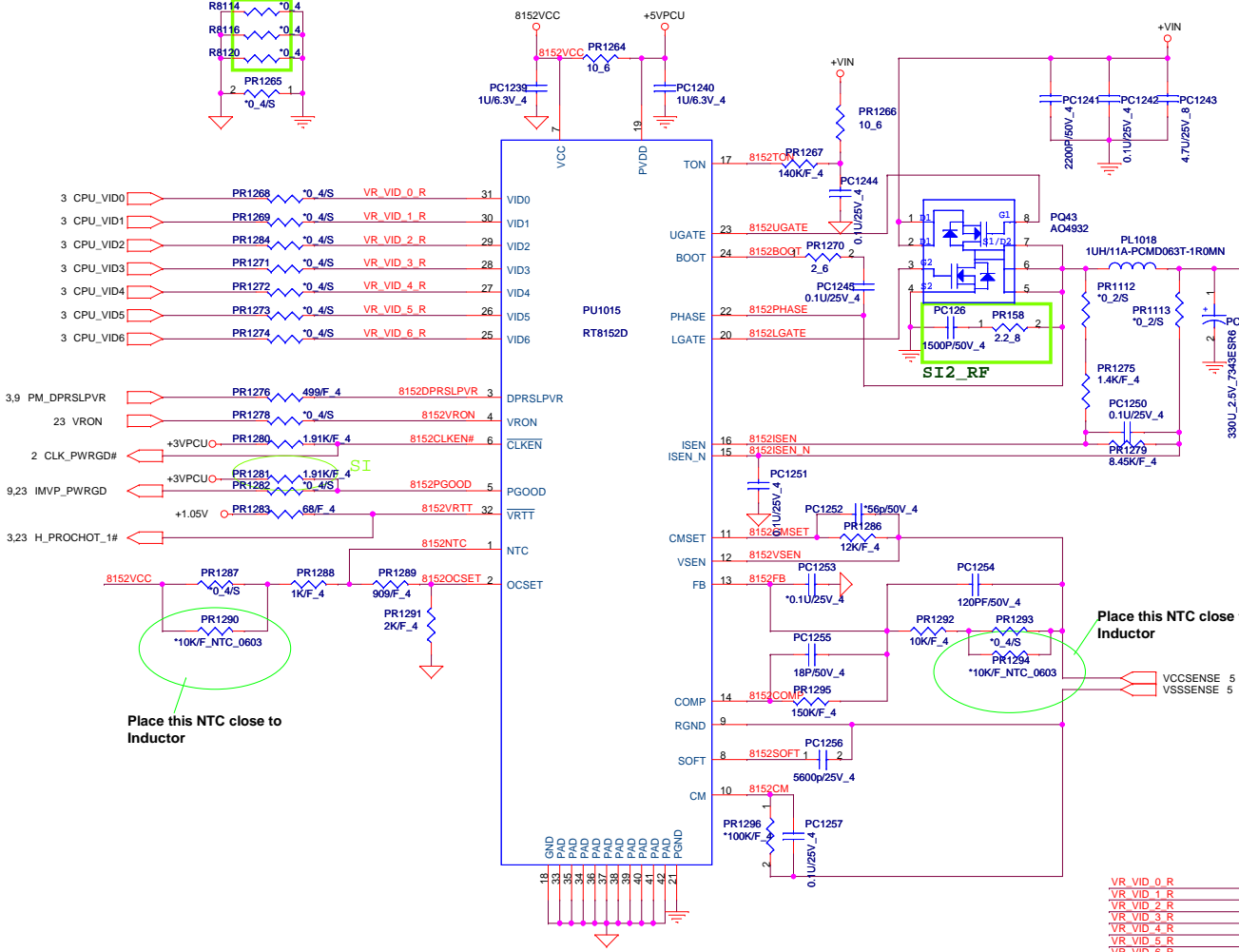
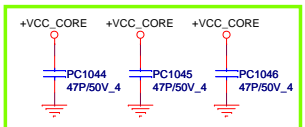

Place this NTC close to Inductor

Place this NTC close to Inductor

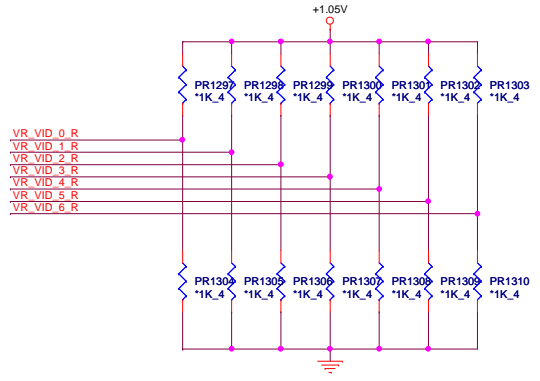

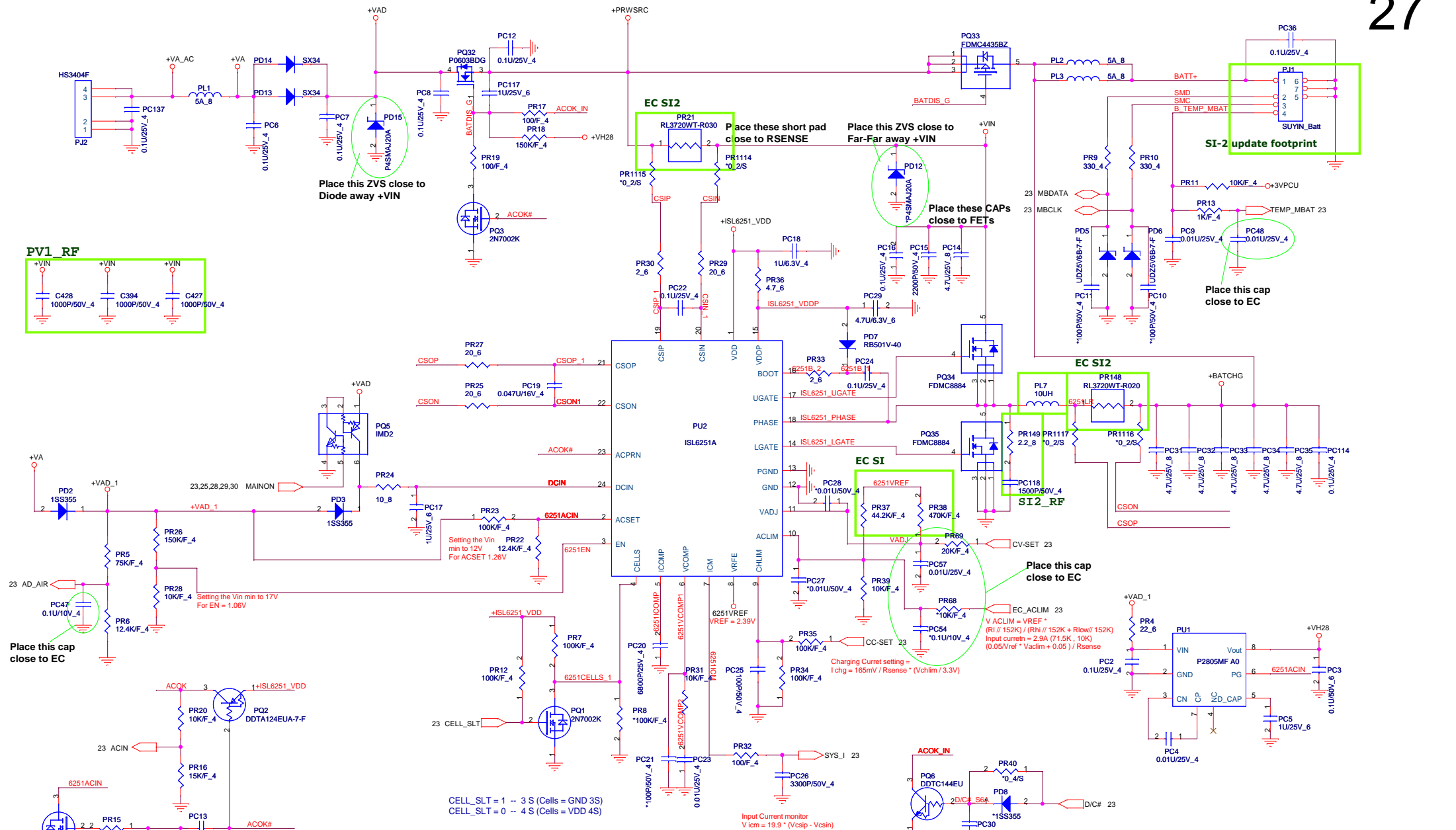

Cells control	Mounted	N/A
3cells only option for 3cells/4cells	PR8 PR7, PR12, PQ1	PR7, PR12, PQ1 PR8

Quanta Computer Inc.
PROJECT : Annika

Size: Document Number: **CHARGER (ISL6251A)** Rev: 1A
 Date: Thursday, October 29, 2009 Sheet: 27 of 32

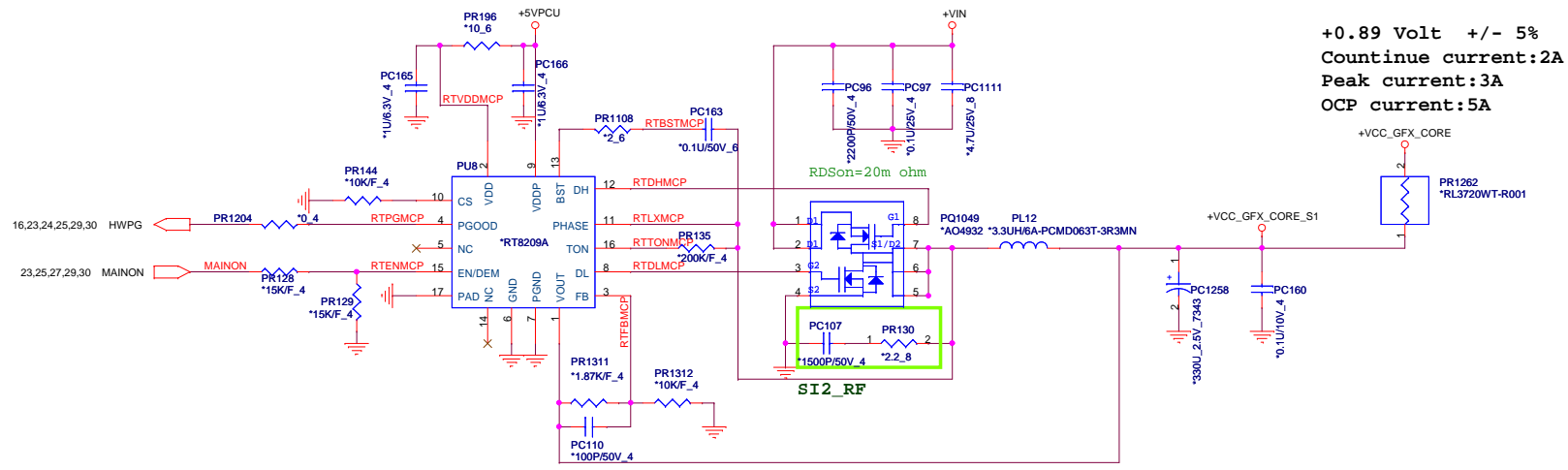

+0.89 Volt +/- 5%
Countinue current:1.38A
Peak current:3A

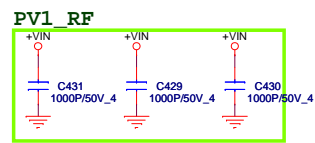
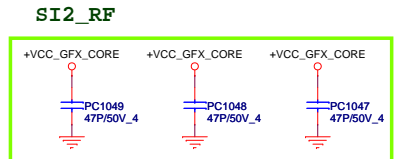
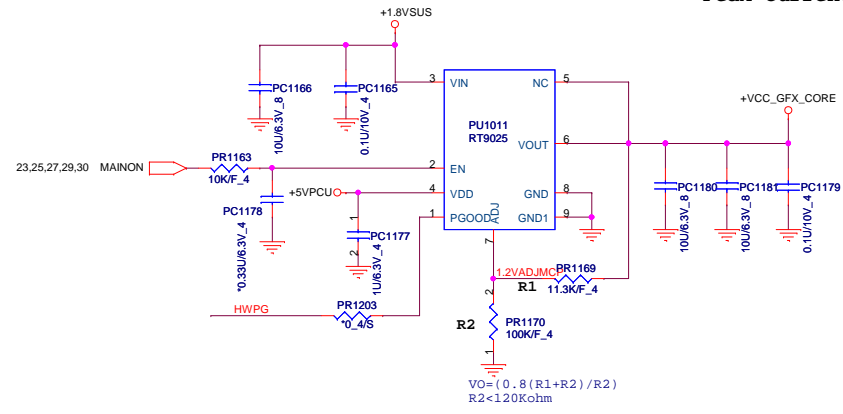

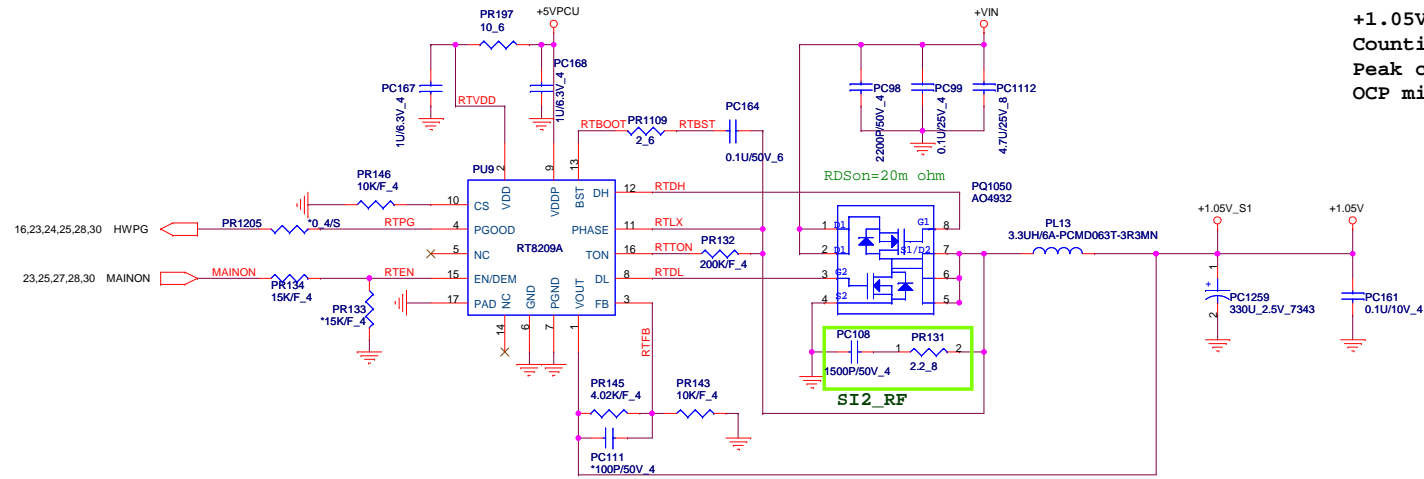

+1.05Volt +/- 5%
 Countinue current:3A
 Peak current:4A
 OCP minimum:5A

SI2_RF

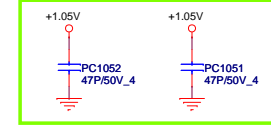

PV1_RF

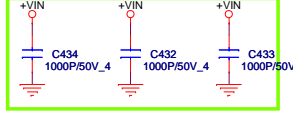

+1.2 Volt +/- 5%
 Countinue current:0.8A
 Peak current:3A

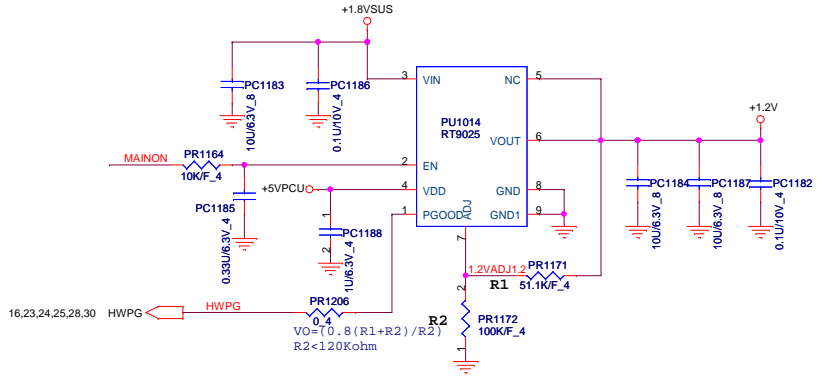

SI2_RF

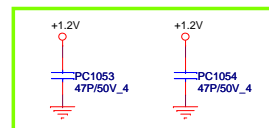

 Quanta Computer Inc. PROJECT : Annika		Rev 1A
Date: Thursday, October 29, 2009	Sheet 29 of 32	

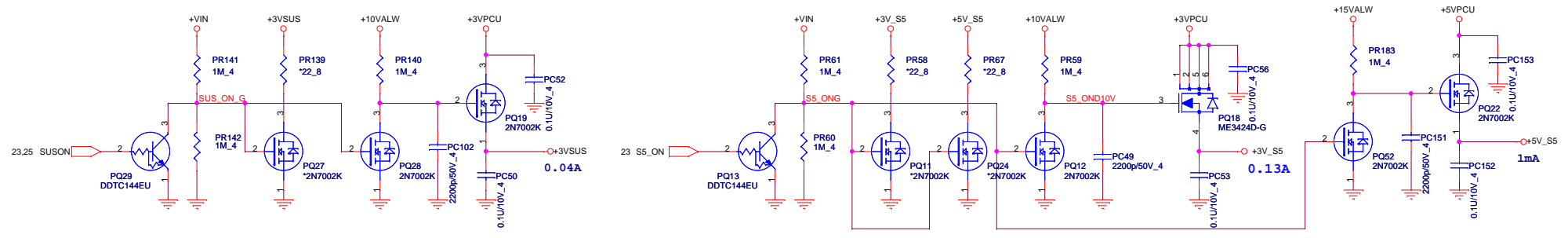
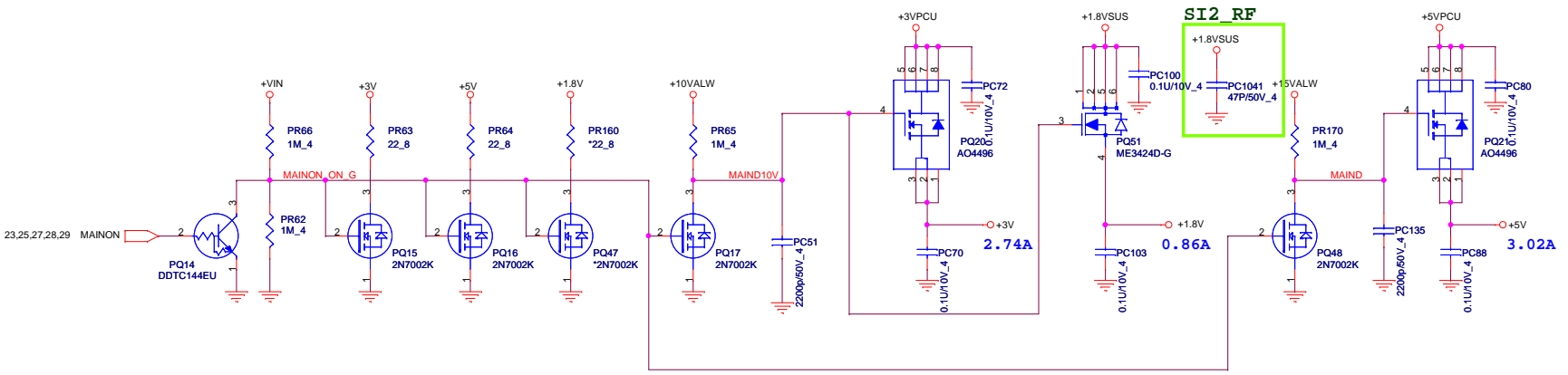

+1.5 Volt +/- 5%
Continue current:2A
Peak current:3A

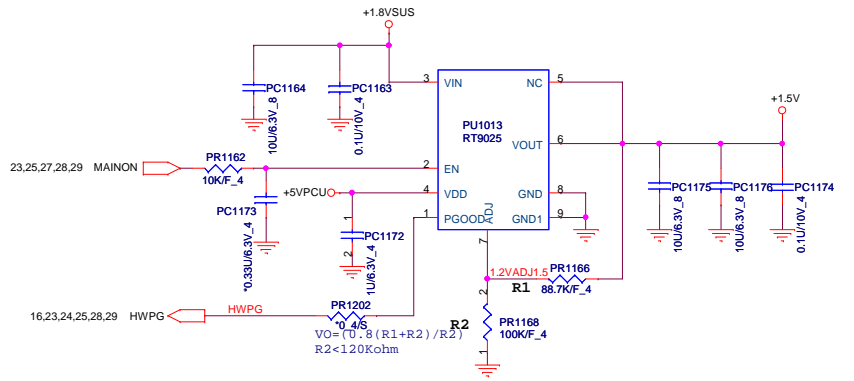
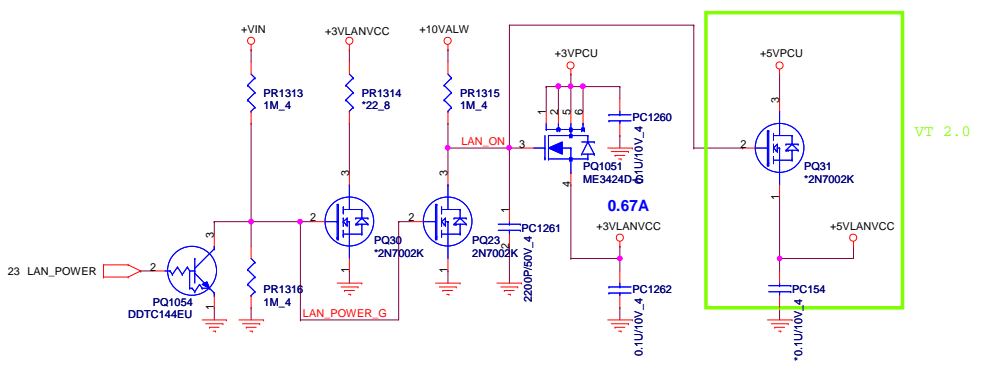

CPU XDP

2,3,5,7,10,14,26,29 +1.05V

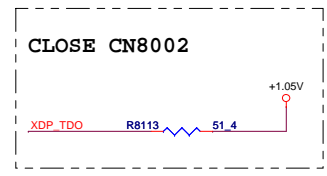
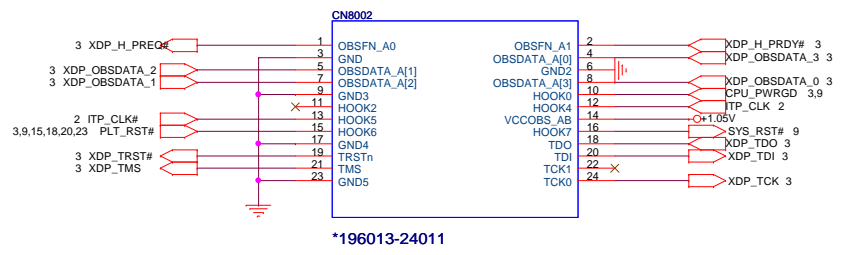

		Quanta Computer Inc. PROJECT : Annika	
		Size: XDP Document Number: XDP	Rev: 1A
Date: Thursday, October 29, 2009		Sheet: 31	of: 32

Power up sequence

