

MS-1682 VER : 0B

- 01_BLOCK DIAGRAM
- 02_PLATFORM
- 03_PENRYN-1 (HOST BUS)
- 04_PENRYN-2 (POWER/GND)
- 05_M672DX-1 (HOST BUS & PCIE)
- 06_M672DX-2 (MutI/O)
- 07_M672DX-3 (DDR2)
- 08_M672DX-4 (POWER)
- 09_M672DX-5 (VSS)
- 10_DDR2 SODIMM 0
- 11_DDR2 SODIMM 1
- 12_DDR2 TERMINATION
- 13_M92M-host-lvds
- 14_M92M-IO
- 15_M92M-power
- 16_M92M-power-straps
- 17_M92M_MEM_Interface
- 18_M92M_DDR2_A0
- 19_M92M_DDR2_A1
- 20_CRT & LVDS CONN
- 21_CLOCK GEN & Dimm BUF
- 22_SIS968-1 (PCI/IDE/SPI/MutI/O)
- 23_SIS968-2 (USB/SATA)
- 24_SIS968-3 (CPU/HD/PCIE/GPIO)
- 25_SIS968-4 (POWER/GND)
- 26_USBX2&Camera&MDC&BT CONN
- 27_HDD & ODD CONN & NEW CARD
- 28_RTS5158E_CARD READER
- 29_PHY LAN (RTL8201CL)
- 30_MINI_PCIECARD & LED & SW
- 31_AUDIO(ALC662) / AMP(APA2031)
- 32_SPK & HP & MIC
- 33_KBC/EC/uP (ENE3925)
- 34_PWRGD & FAN & C3/C4
- 35_Battery select
- 36_Battery Charger
- 37_M_System Power
- 38_M_1.8V & SMDRR_VTERM & 1.5V
- 39_M_1.2V & VTT power
- 40_VGA power
- 41_CPU power
- 42_Screw
- 43_EMI
- 44_Power Sequence-1
- 45_Power Sequence-2
- 46_Power Sequence_3
- 47_Launch Board
- 48_TP Board
- 49_USBx2 & RJ45 & RJ11 Board

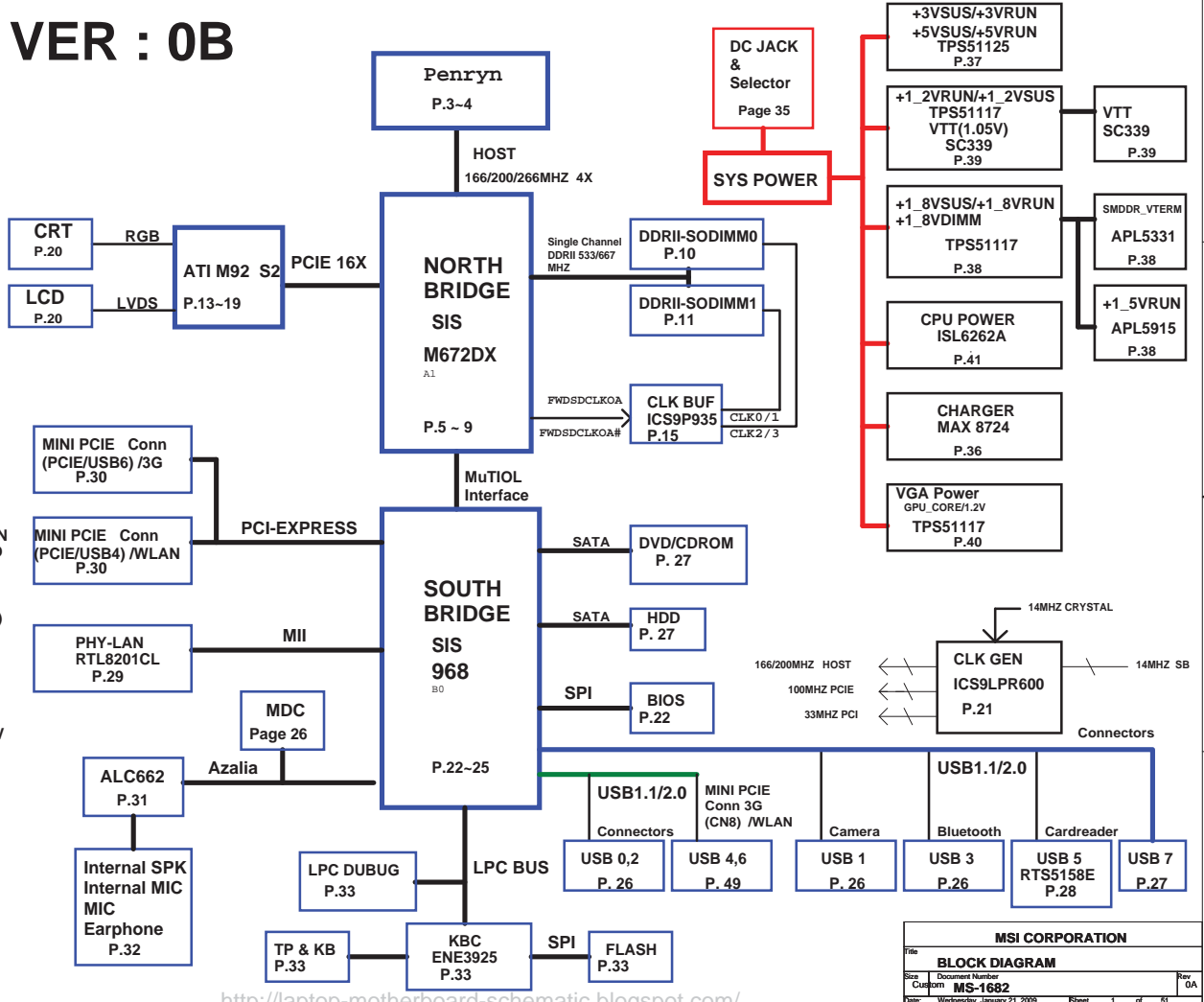

MSI CORPORATION		
File:	BLOCK DIAGRAM	
Size:	Document Number:	Rev: 0A
Custom:	MS-1682	
Date:	Wednesday, January 21, 2009	Sheet 1 of 51

<http://laptop-motherboard-schematic.blogspot.com/>

Voltage Rails

Voltage	Description	Control Signal
PWR_SRC	AC ADAPTER OR BATTERY IN	
V_CORE	Core Voltage for Processor	VR_ON
+VTT	1.05 rail for Processor & SIS968 GTL IO	+1_5VM_PG
+1_5VRUN	1.5V switched power rail(off in S3-S5)	+5VRUN
+1_2VRUN	1.2V power rail SISM672FX Analog (off in S3-S5)	RUND (RUN_ON)
+3VRUN	3.3V switched power rail(off in S3-S5)	RUND (RUN_ON)
+5VRUN	5.0V switched power rail(off in S3-S5)	RUND (RUN_ON)
SMDDR_VTERM	0.9V DDR Termination voltage (off in S4-S5)	RUN_ON
+1_8VDIMM	1.8V power rail DDRII (off in S4-S5)	DIMM_ON
+1_8VRUN	1.8V power for SIS968 MuTIOL IO and core logic (off in S3-S5)	RUND (RUN_ON)
+1_8VSUS	1.8V power rail for SB core logic (off in S4-S5)	SUS_ON
+3VSUS	3.3V power rail (off in S4-S5)	SUS_ON
+5VSUS	5.0V power rail (off in S4-S5)	SUS_ON
+3VALW	3.3V always on power rail	PWR_SRC
+5VALW	5.0V always on power rail	PWR_SRC
+V5_AUDIO	5.0V Power rail Audio codec(off in S3-S5)	RUND
+1_2VSUS	1.2V power rail SISM672FX Digital (off in S4-S5)	SUS_ON

POWER STATES

STATE	SIGNAL	SLP_S3#	SLP_S5#	+V*ALWAYS	+V*SUS	+V*RUN	Clocks	+1_8VDIMM
Full ON		HIGH	HIGH	ON	ON	ON	ON	ON
S1(Power On Suspend)		HIGH	HIGH	ON	ON	ON	LOW	ON
S3(Suspend to RAM)		LOW	HIGH	ON	ON	OFF	OFF	ON
S4(Suspend to Disk)		LOW	LOW	ON	OFF	OFF	OFF	OFF
S5 / Soft OFF		LOW	LOW	ON	OFF	OFF	OFF	OFF

Note : WHEN AC MODE , System turn on then +V*SUS will always keep high

MSI CORPORATION		
Title	PLATFORM	
Size	Document Number	Rev
Custom	MS-1682	0A
Date	Wednesday, January 21, 2009	Sheet 2 of 51

5 H_ADSP[3:1] H_ADSP[3]
 5 H_RS[2:0] H_RS[2:0]
 5 H_REQ[4:0] H_REQ[4:0]

5 H_DP[63:0] H_DP[63:0]

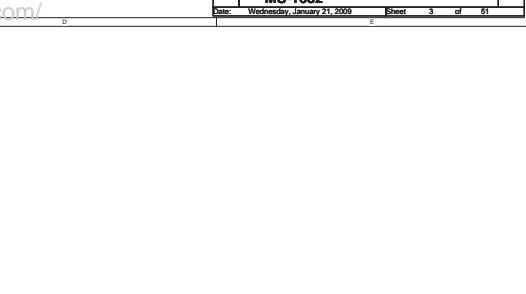
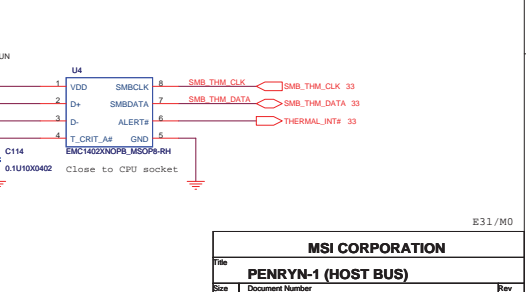
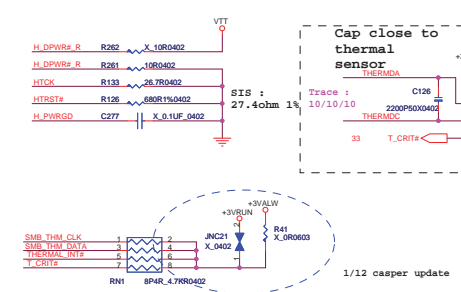
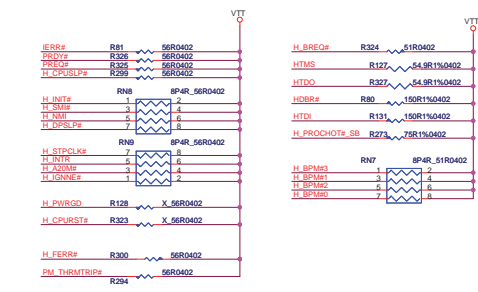
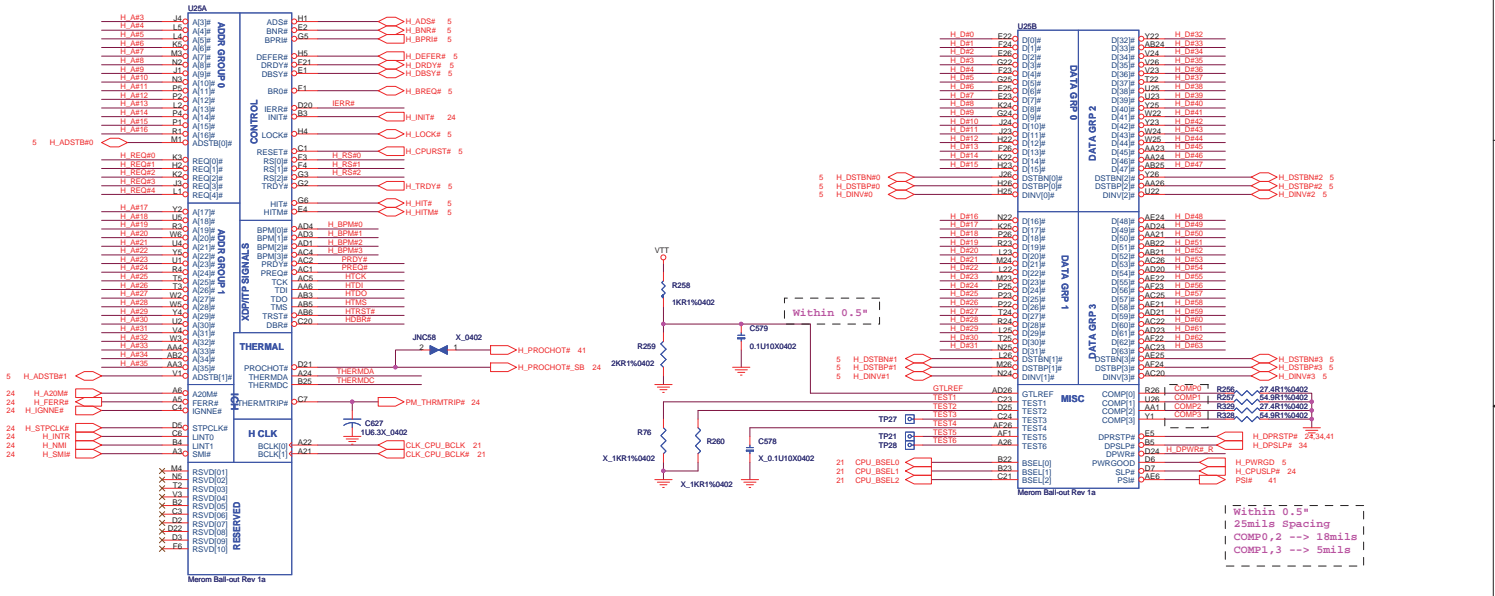

<http://laptop-motherboard-schematic.blogspot.com/>

E31/M0

MSI CORPORATION

File: **PENRYN-1 (HOST BUS)**

Size: Document Number

Custom: **MS-1682** Rev 0A

Date: Wednesday, January 21, 2009 Sheet 3 of 51

U29D			
A1	VSS001	VSS082	P6
A1	VSS002	VSS083	P24
A13	VSS003	VSS084	P2
A13	VSS004	VSS085	R4
A19	VSS005	VSS086	R2
A19	VSS006	VSS087	R22
K21	VSS007	VSS088	R26
AE2	VSS008	VSS089	T1
BE	VSS009	VSS090	T2
BE	VSS010	VSS091	T23
B11	VSS011	VSS092	T26
B11	VSS012	VSS093	T12
B19	VSS013	VSS094	L21
B19	VSS014	VSS095	L2
B24	VSS015	VSS096	V2
B24	VSS016	VSS097	V2
C9	VSS017	VSS098	W1
CS	VSS018	VSS099	W2
C11	VSS019	VSS100	V25
C14	VSS020	VSS101	W1
C16	VSS021	VSS102	W4
C19	VSS022	VSS103	W23
C2	VSS023	VSS104	W26
C2	VSS024	VSS105	W6
D1	VSS025	VSS106	Y1
D4	VSS026	VSS107	Y24
D8	VSS027	VSS108	AA2
D11	VSS028	VSS109	AA5
D11	VSS029	VSS110	AA8
D13	VSS030	VSS111	AA9
D16	VSS031	VSS112	AA11
D19	VSS032	VSS113	AA14
D23	VSS033	VSS114	AA16
D26	VSS034	VSS115	AA19
E3	VSS035	VSS116	AA22
E6	VSS036	VSS117	AA25
E11	VSS037	VSS118	AB1
E14	VSS038	VSS119	AB4
E16	VSS039	VSS120	AB8
E19	VSS040	VSS121	AB11
E21	VSS041	VSS122	AB16
E24	VSS042	VSS123	AB19
E4	VSS043	VSS124	AB26
E4	VSS044	VSS125	AC2
FA	VSS045	VSS126	AC6
F11	VSS046	VSS127	AC9
F13	VSS047	VSS128	AC6
F14	VSS048	VSS129	AC8
F19	VSS049	VSS130	AC11
F2	VSS050	VSS131	AC14
F2	VSS051	VSS132	AC16
G1	VSS052	VSS133	AC21
G1	VSS053	VSS134	AC24
G21	VSS054	VSS135	AD2
G2	VSS055	VSS136	AD5
G26	VSS056	VSS137	AD8
H3	VSS057	VSS138	AD11
H6	VSS058	VSS139	AD11
H21	VSS059	VSS140	AD13
H24	VSS060	VSS141	AD16
J5	VSS061	VSS142	AD16
J5	VSS062	VSS143	AD22
J2	VSS063	VSS144	AD25
J2	VSS064	VSS145	AE1
K1	VSS065	VSS146	AE4
K1	VSS066	VSS147	AE8
K2	VSS067	VSS148	AE11
K26	VSS068	VSS149	AE14
L3	VSS069	VSS150	AE16
L6	VSS070	VSS151	AE19
L21	VSS071	VSS152	AE22
L24	VSS072	VSS153	AE26
M2	VSS073	VSS154	AE2
M3	VSS074	VSS155	AE6
M3	VSS075	VSS156	AE8
M3	VSS076	VSS157	AE11
N4	VSS077	VSS158	AE16
N21	VSS078	VSS159	AE19
N21	VSS079	VSS160	AE26
N26	VSS080	VSS161	AE2
PA	VSS081	VSS162	AE6
PA	VSS082	VSS163	AE25

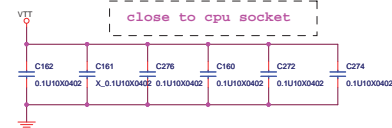
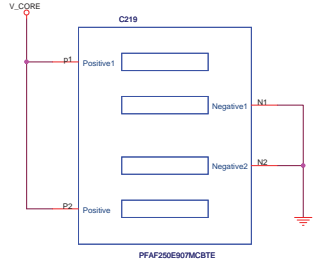
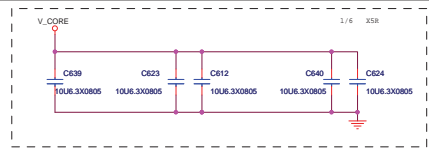
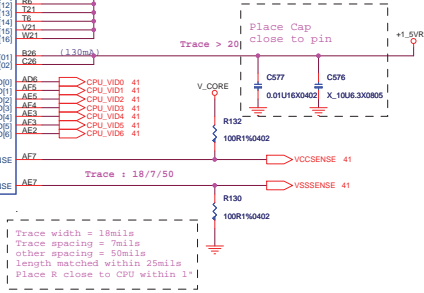
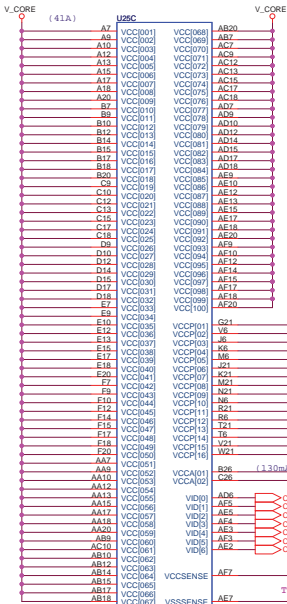

<http://lappp-motherboard-schematic.blogspot.com/>

E1.2/M0

MSI CORPORATION

File: **PENRYN-2 (POWER/GND)**

Size: Custom Document Number: **MS-1682** Rev: 0A

Date: Wednesday, January 21, 2009 Sheet: 4 of 51

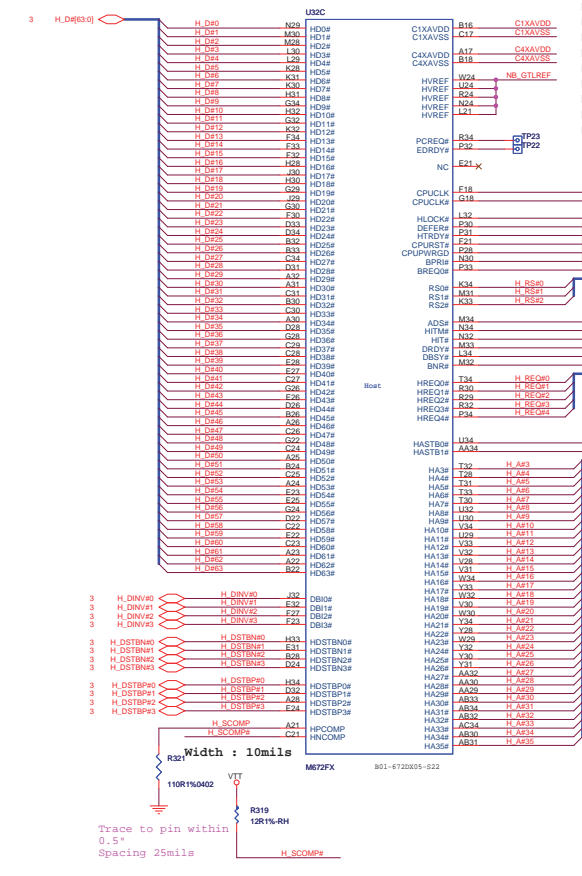
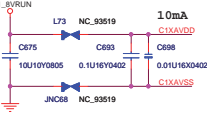
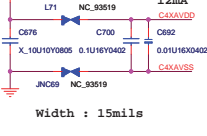
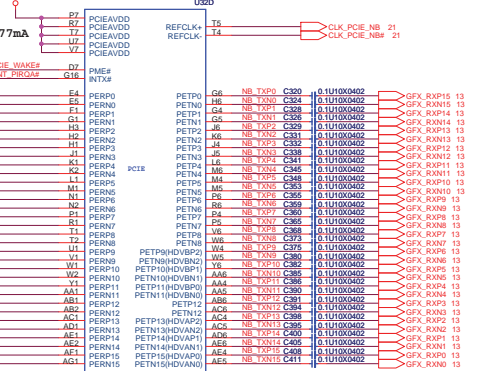
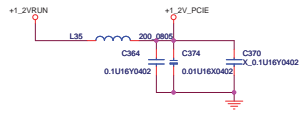
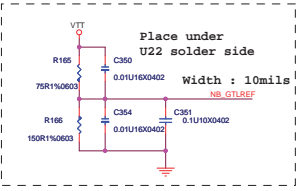

MSI CORPORATION			
File	672DX-1 (HOST BUS & PCIE)		
Size	Document Number	Rev 0A	
Custom	MS-1682		
Date	Wednesday, January 21, 2009	Sheet	6 of 61

<http://lappp-motherboard-schematic.blogspot.com/>

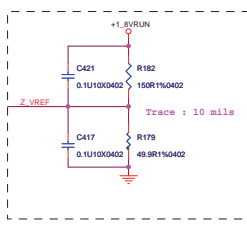
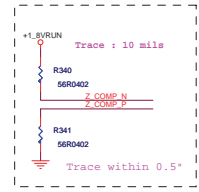
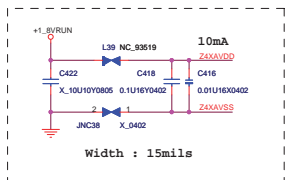
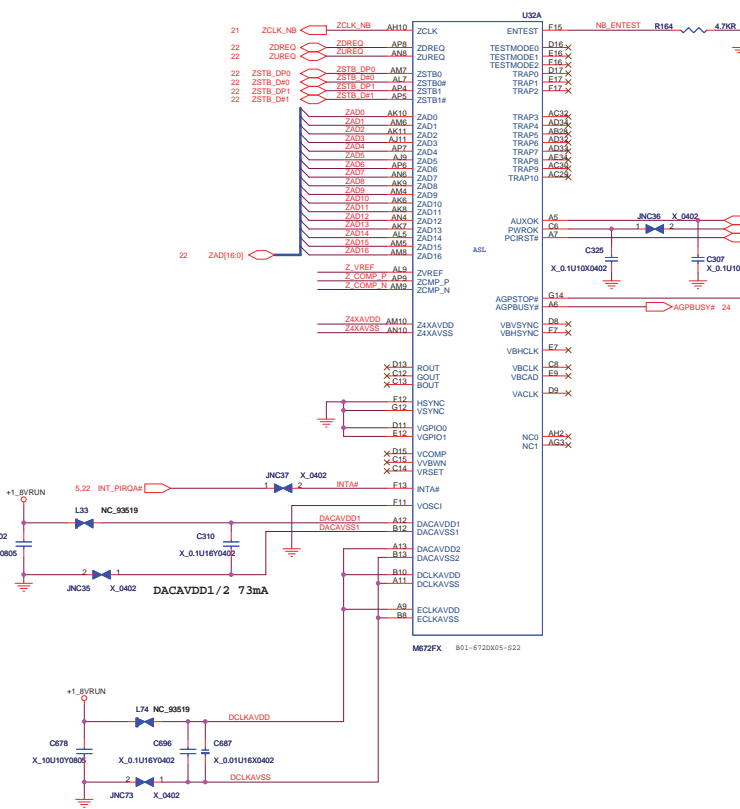

ME72FX 801-6722005-022

<http://laptop-motherboard-schematic.blogspot.com/>

E1.2/M0

MSI CORPORATION			
File: 672DX-2 (MultiO&VGA)			
Size: Custom	Document Number: MS-1682	Rev: 0A	
Date: Wednesday, January 21, 2009	Sheet: 6	of 61	

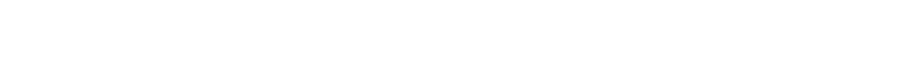
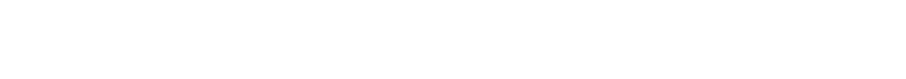
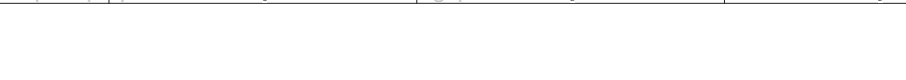
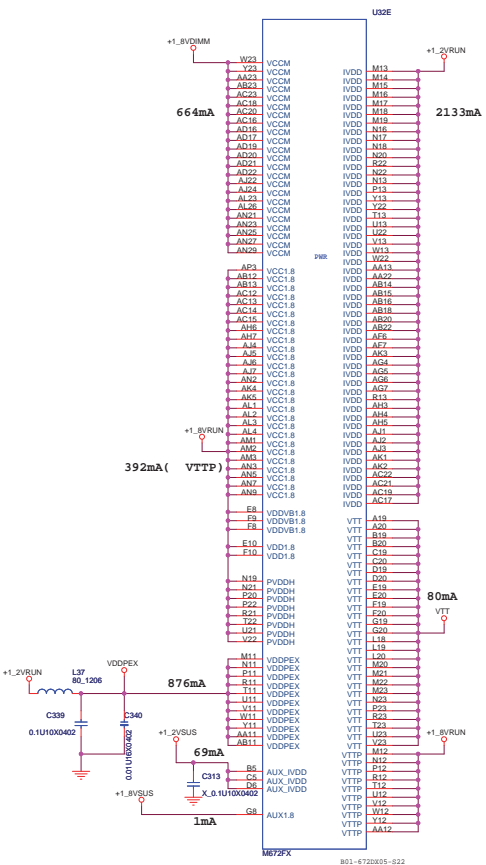

MSI CORPORATION		
File: 672DX-5 (POWER)		
Size: Custom	Document Number: MS-1682	Rev: 0A
Date: Wednesday, January 21, 2009	Sheet: 8	of 51

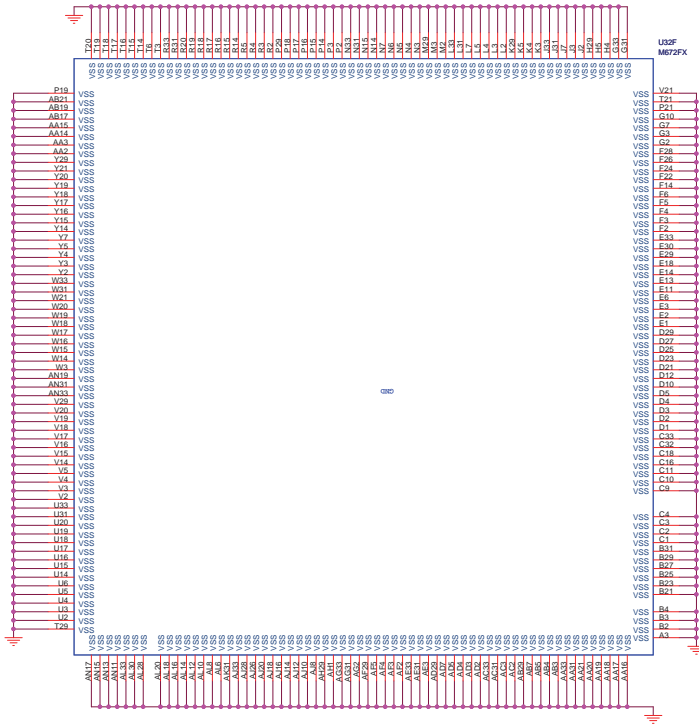

B01-672DX-6-822

<http://lappp-motherboard-schematic.blogspot.com/>

MSI CORPORATION		
File	672DX-6 (VSS)	E1 / M0
Size	Document Number	Rev
Custom	MS-1682	0A
Date	Wednesday, January 21, 2009	Sheet 8 of 81

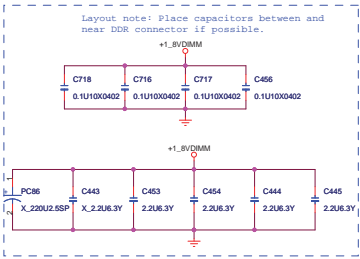
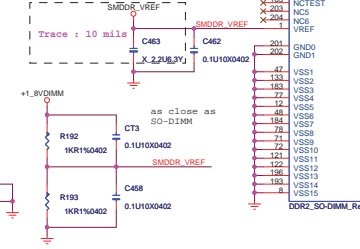
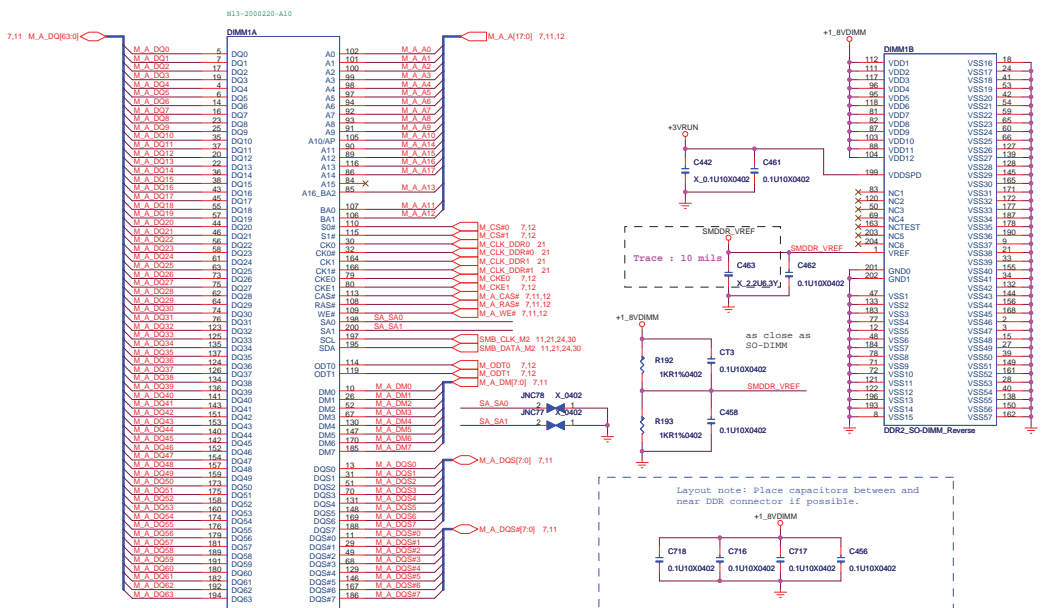

E16/P0

MSI CORPORATION	
Title	DDR2 SODIMM 0
Size	Document Number
Custom	MS-1682
Date	Wednesday, January 21, 2009
Sheet	10 of 51

<http://laptop-motherboard-schematic.blogspot.com/>

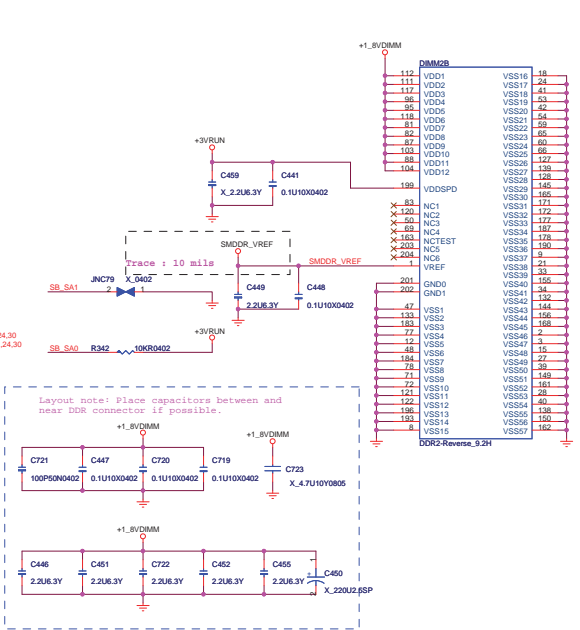
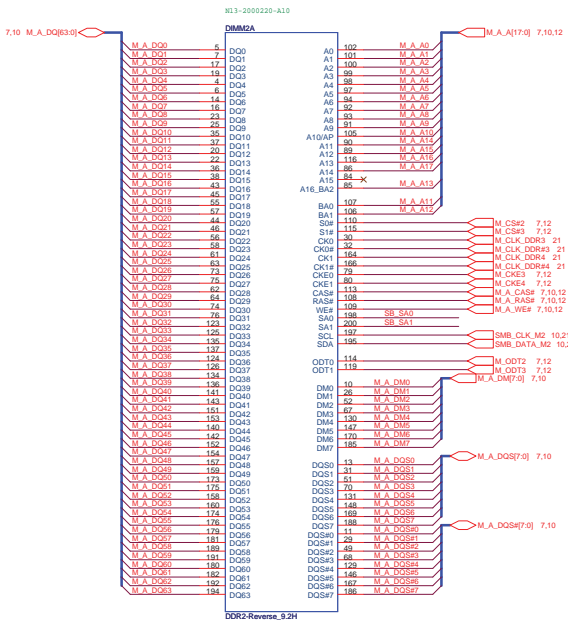

B12/M0

MSI CORPORATION		
File	DDR2 SODIMM 1	
Size	Document Number	Rev
Custom	MS-1682	0A
Date	Wednesday, January 21, 2009	Sheet 11 of 51

<http://laptop-motherboard-schematic.blogspot.com/>

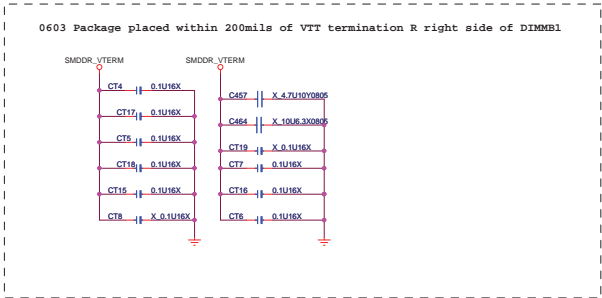
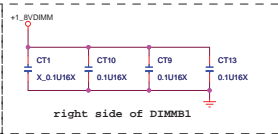
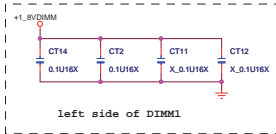
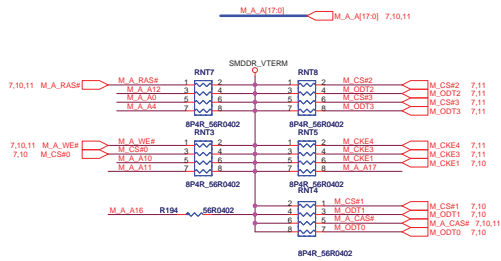
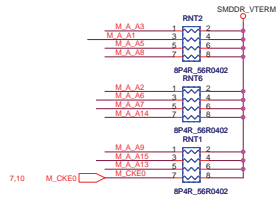
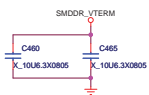

MSI CORPORATION		
Title: DDR2 TERMINATION		
Size: Custom	Document Number: MS-1682	Rev: 0A
Date: Wednesday, January 21, 2009	Sheet: 12	of 61

U22A

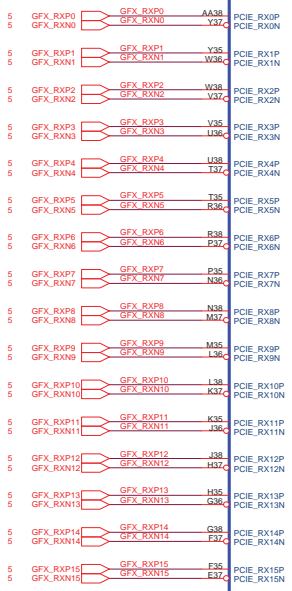

PCI EXPRESS INTERFACE

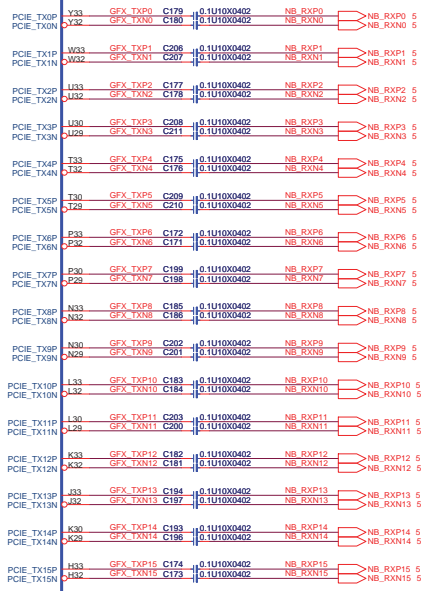

216-0729012-00

LVDS Interface

U22G

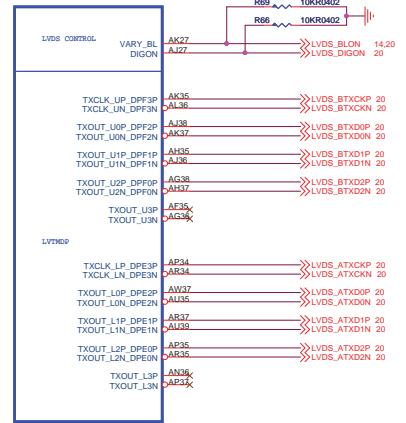

216-0729012-00

B03-00M5235-A08

DisplayPort E Configuration

<http://laptop-motherboard-schematic.blogspot.com/>

E43/M0

MSI CORPORATION		
File	M92M-HOST/LVDS	
Size	Document Number	Rev
Custom	MS-1682	0A
Date	Wednesday, January 21, 2009	Sheet 13 of 51

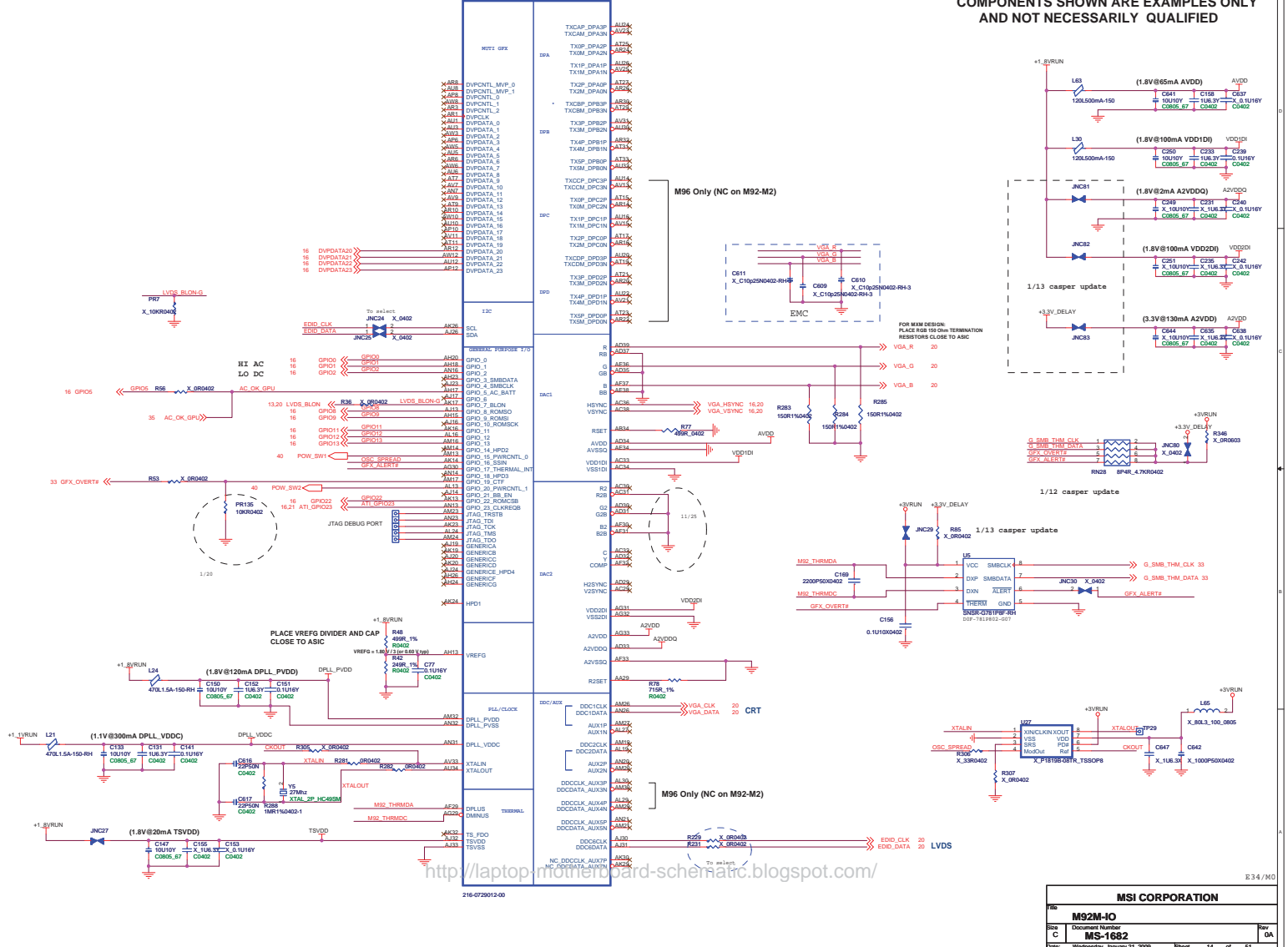

<http://laptop-motherboard-schematic.blogspot.com/>

MSI CORPORATION		
File:	M92M-IO	
Site:	Document Number:	MS-1682
C:		Rev: 0A
Date:	Wednesday, January 21, 2009	Page: 14 of 51

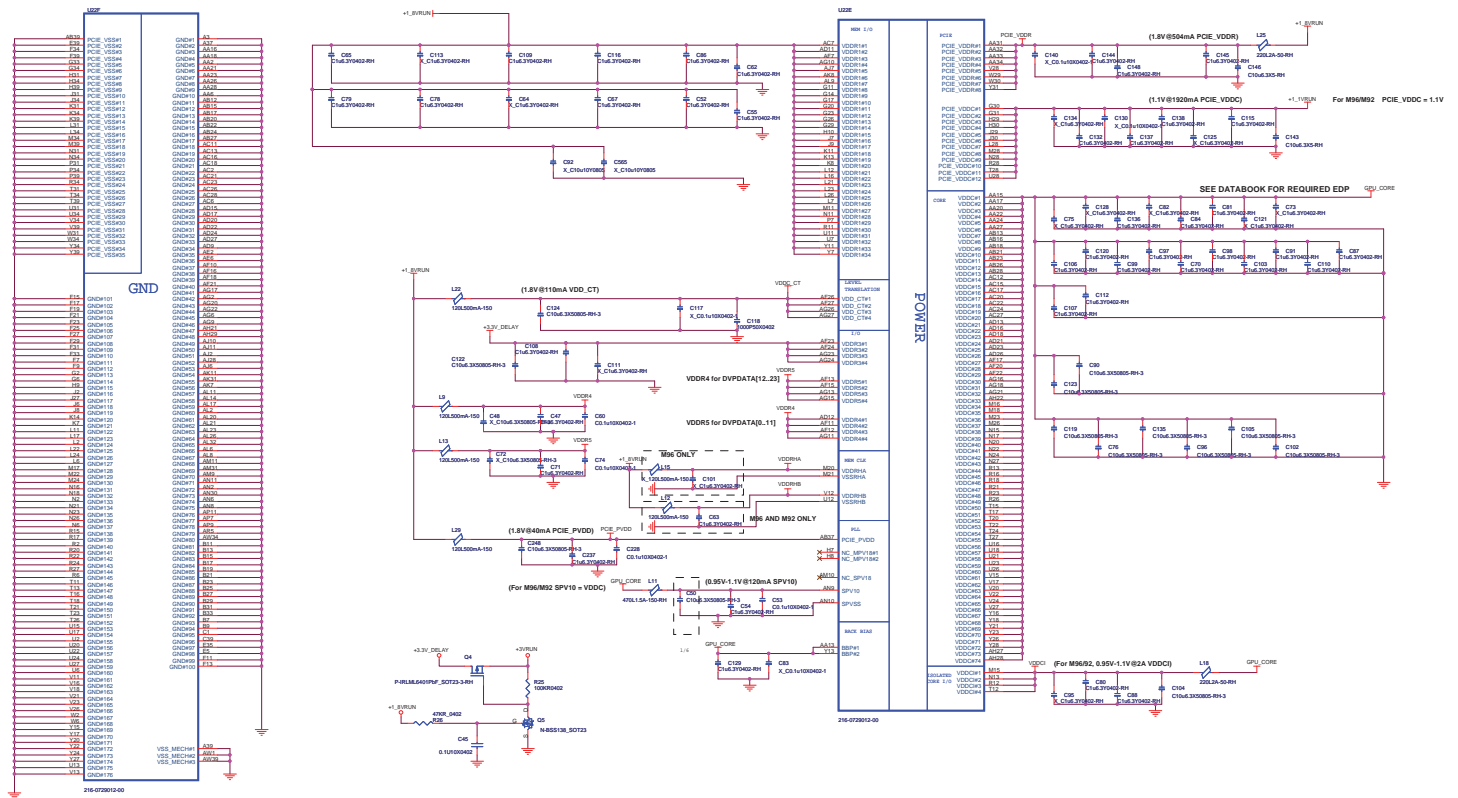

MSI CORPORATION

M92M-POWER	
Chipset	MS-1682
Rev	1.0
Date	2008.04.29
Sheet	11 of 11

<http://laptop-motherboard-schematic.blogspot.com/>

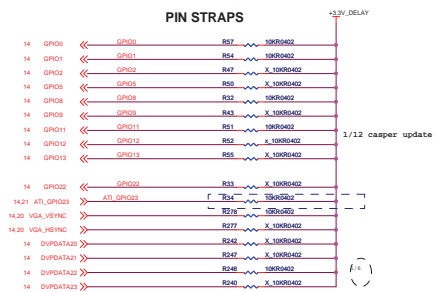
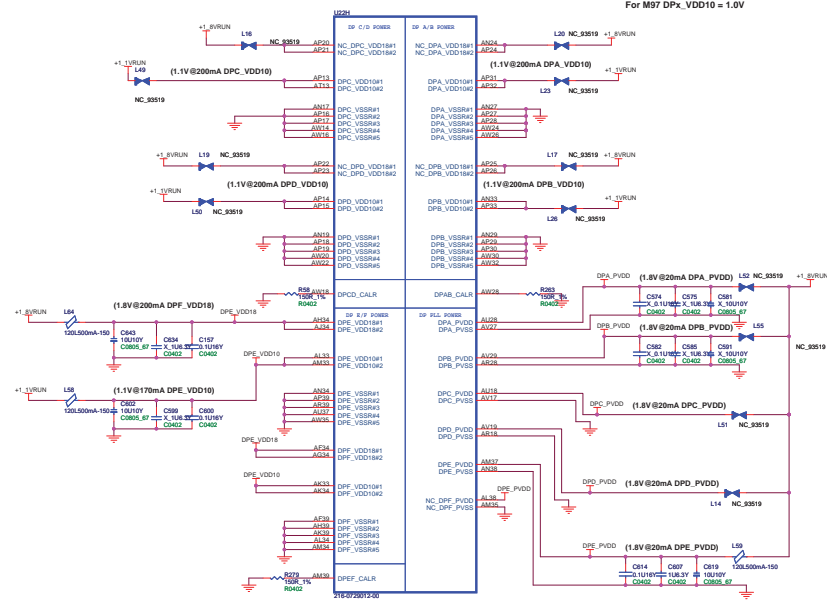

CONFIGURATION STRAPS
ALLOW FOR PULLUP PADS FOR THESE STRAPS AND IF THESE GPIOs ARE USED, THEY MUST NOT CONFLICT DURING RESET

STRAPS	PIN	DESCRIPTION OF DEFAULT SETTINGS	RECOMMENDED SETTINGS
TX_PWRS_ENB	GPIO0	Transmitter Power Saving Enable 0:20% Tx output saving (default setting for desktop) 1:Full Tx output saving (default setting for desktop)	1
TX_DEEMPH_EN	GPIO1	PCI Express Transmitter De-emphasis Enable 0:Tx de-emphasis disabled for mobile mode 1:Tx de-emphasis enable (default setting for desktop)	1
BIF_GEN2_EN	GPIO2	0 = Advertises the PCI-E device as 2.0 GT/s capable at power-on 1 = Advertises the PCI-E device as 3.0 GT/s capable at power-on 2:0 GT/s Capability will be controlled by	0
STRAP_BIF_CLK_PA_EN	GPIO8	Enables CLKREQ Power Management 0:CLKREQ Power Management capability is disabled 1:CLKREQ Power Management capability is enabled	0
BIF_VGA_DIS	GPIO9	VGA ENABLED	0
BIF_RX_FLT_CALIB_BP	GPIO21	BIF_RX_FLT_CALIB_BP	0
BIOS_ROM_EN	GPIO_22, R0MC38	Enables external BIOS ROM device 0: disable external BIOS ROM device 1: enable external BIOS ROM device	0
config2 T 0	GPIO13 12 11	GPIO 0,13,12,11(CONFIG_0,1,2,1,0) 0: If BIOS_ROM_EN is 0, then Config[13] defines the rom type 1: If BIOS_ROM_EN is 0, then Config[12] defines the rom type 2: If BIOS_ROM_EN is 0, then Config[11] defines the Aperture size	0 0 1 256MB
Mem type	DVDDAP021,22	If VIP_DEVICE_STRAP_EN is set to 'Y' then this pin is used to sense whether a VIP device is connected to the VIP bus (between a VIP_DEVICE_STRAP_EN is set to 'Y' and this pin is not used as a strap at all). Its value during reset is unimportant, and it can be used as a regular GPIO	0 0 0 vendor
VIP_DEVICE_STRAP_EN	V5VINC		0
RSVD	HS2VINC		0
RSVD	GENERIC		0
AUX0	HS3VINC		1
AUX1	VS3VINC		1

DV DATA	23	22	21	20	
SAMSUNG	0	0	0	0	32*16
Hynix	0	0	0	1	32*16
SAMSUNG	0	0	1	0	64*16
Hynix	0	1	0	0	64*16

MSI CORPORATION

MS-1682

Version: 1.0

Copyright © 2008

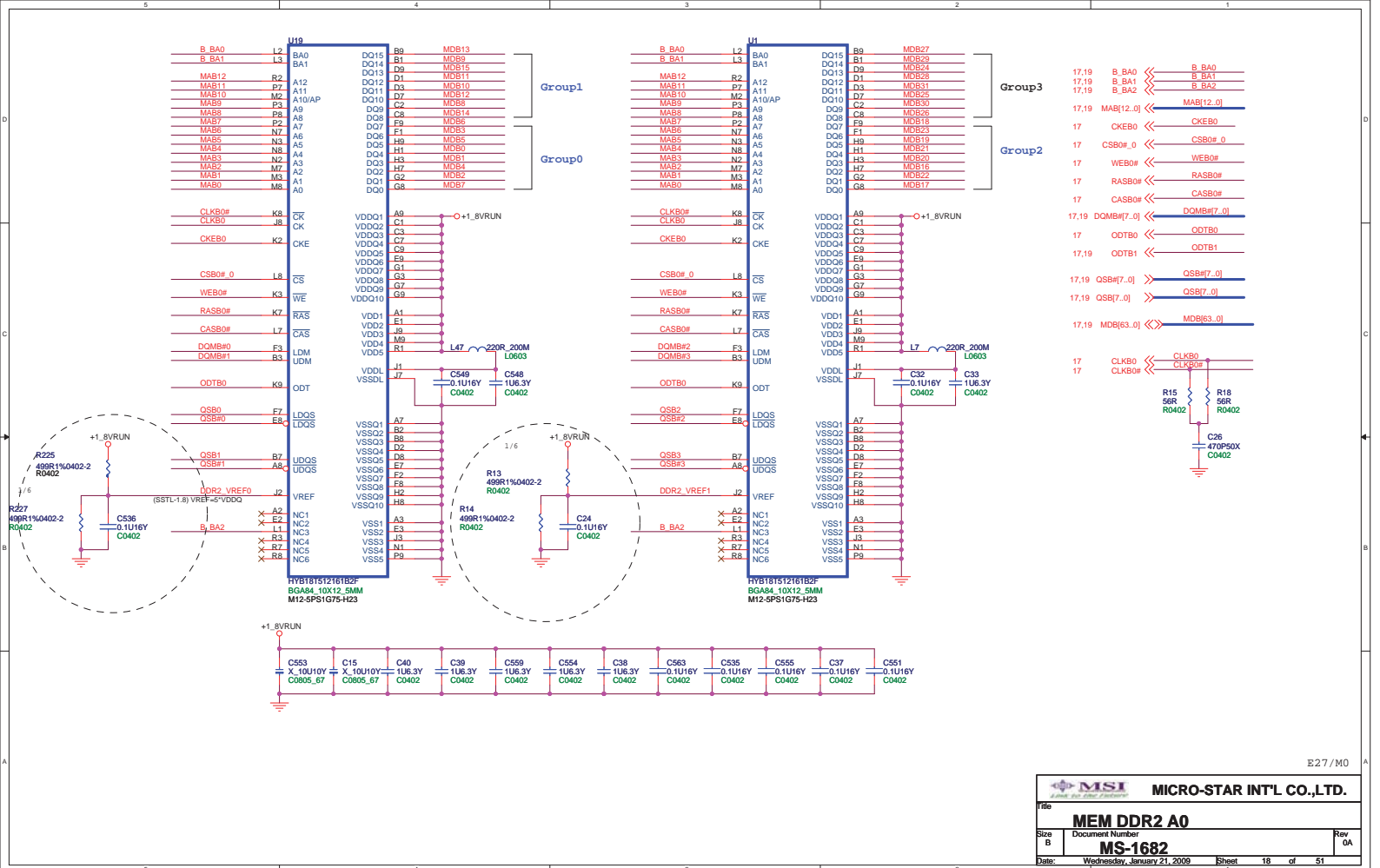

MSI
Micro-Star International, Inc.

MICRO-STAR INTL CO.,LTD.

File		MEM DDR2 A0	
Size		Document Number	
B		MS-1682	
Date:	Wednesday, January 21, 2009	Sheet	18 of 51

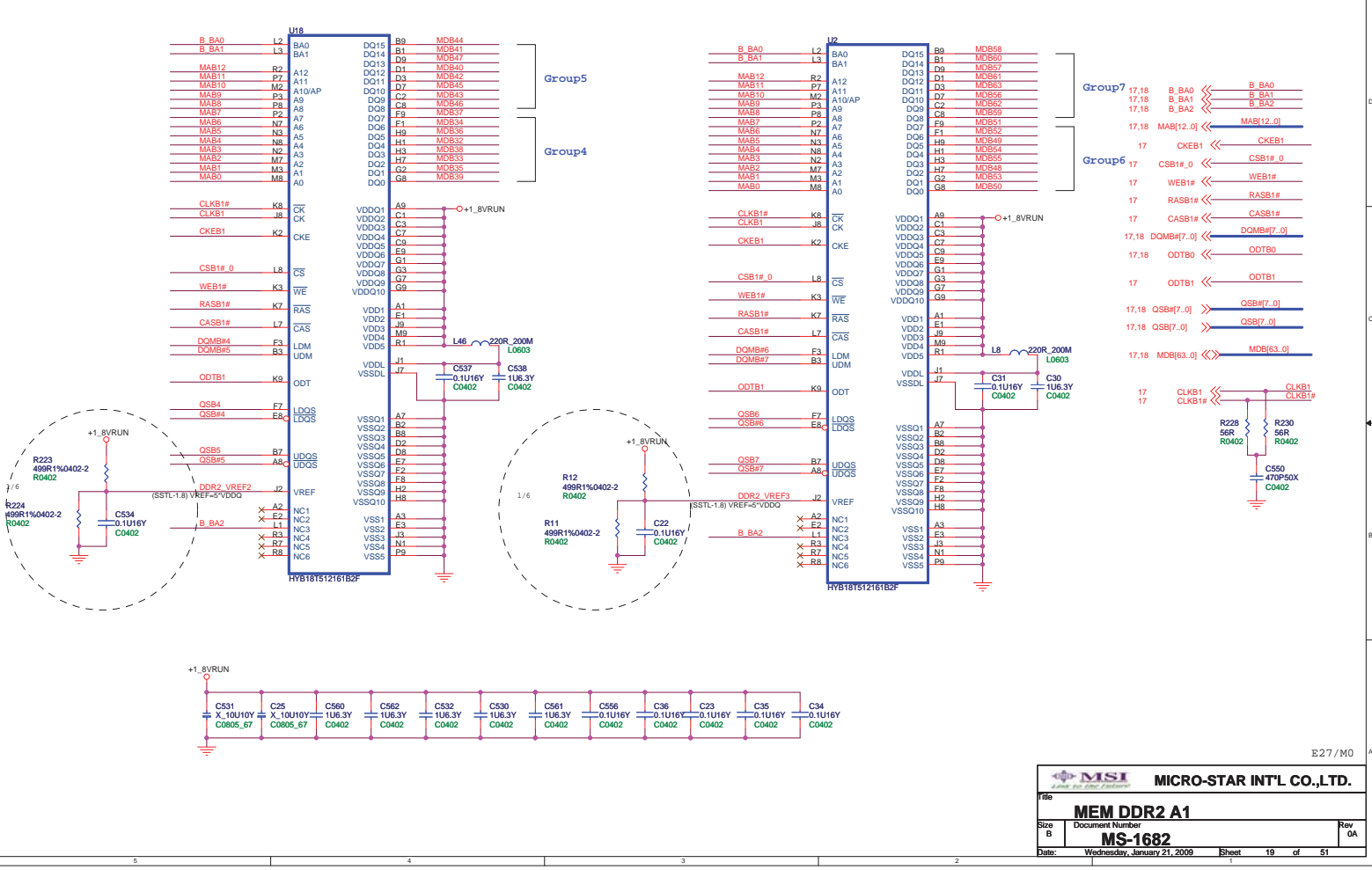

MSI MICRO-STAR INT'L CO., LTD.

File: **MEM DDR2 A1**

Size: B Document Number: **MS-1682** Rev: 0A

Date: Wednesday, January 21, 2009 Sheet: 19 of 51

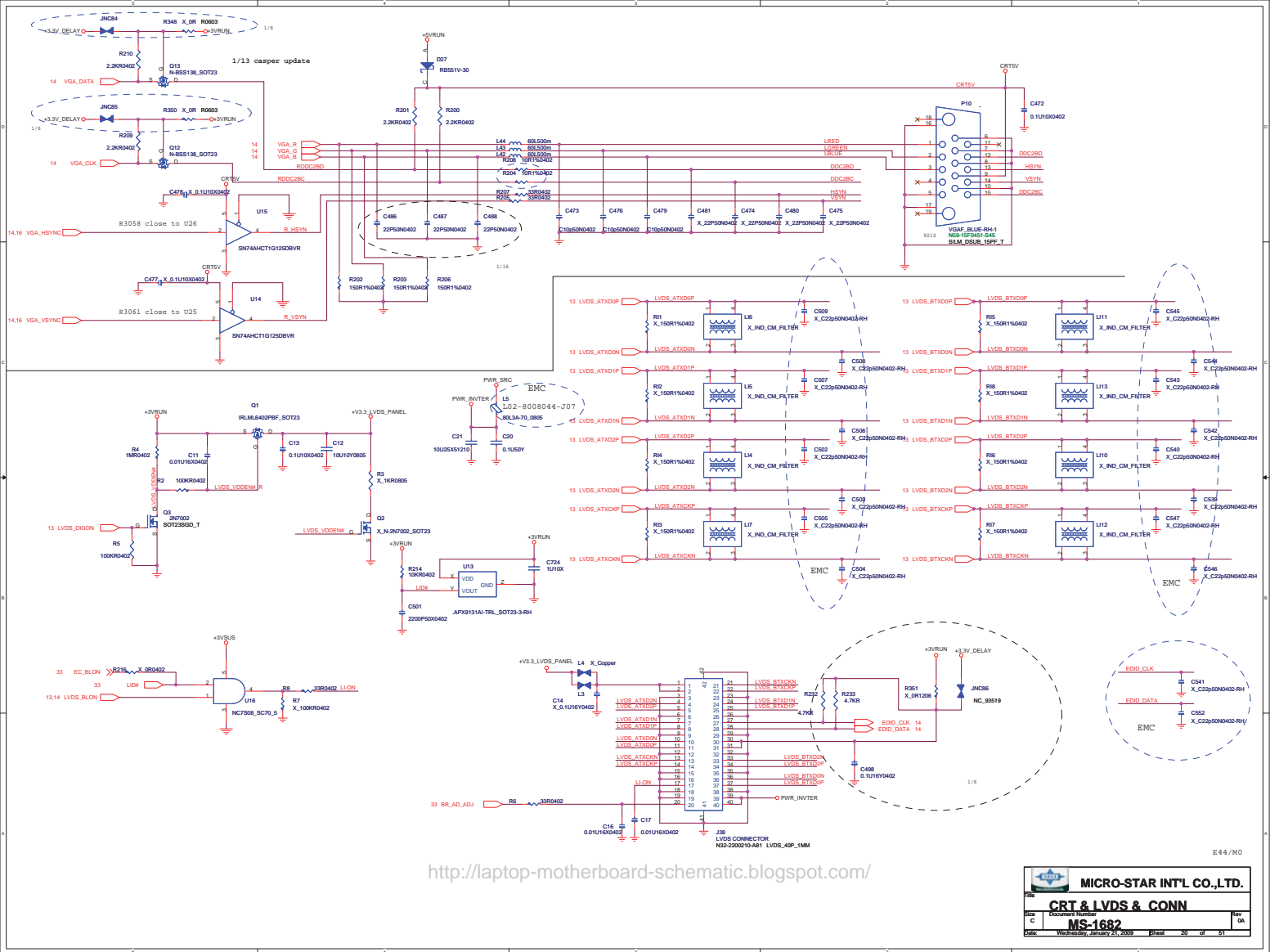

E44/300

<http://laptop-motherboard-schematic.blogspot.com/>

MICRO-STAR INT'L CO., LTD.	
CRT & LVDS & CONN	
MS-1682	
Rev	DA
Date	Wednesday, January 21, 2009
Sheet	20 of 51

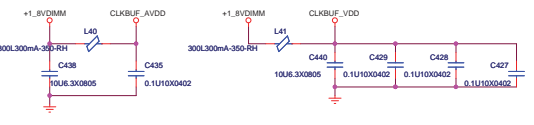
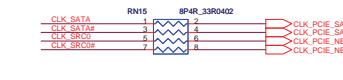
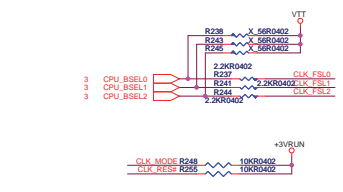
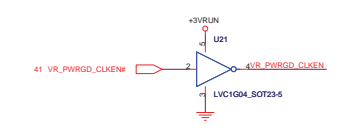

Strapping Configuration (IC5)

PIN#	High	Low (Default)
15	Pin 16/17 : PCLKREQ	Pin 16/17 : PCICLK

CPU Table			FSB Freq (MHz)
BSEL[2]	BSEL[1]	BSEL[0]	667 MHz
L	H	H	800 MHz
L	L	L	1066 MHz

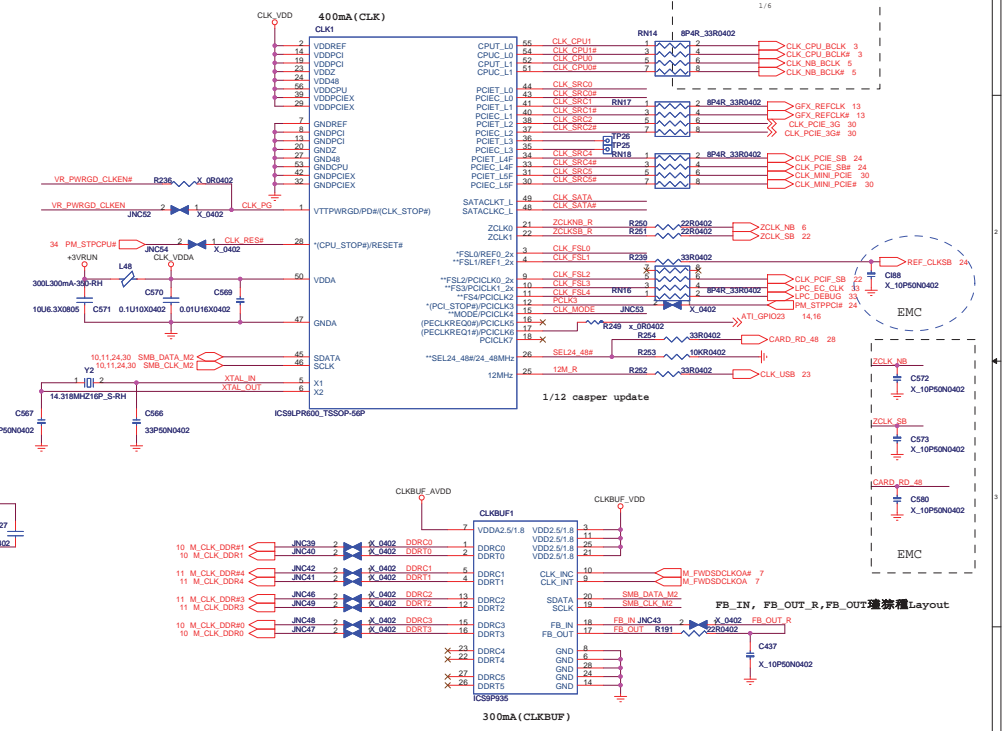
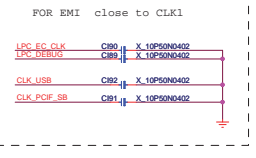

1/16 JNC39,40,41,42 +1.5" AND JNC43 +2" FOR 3D MARK 06 BUG ,

MSI CORPORATION
CLOCK Generator ' Dimm BUF
 Size: Custom Document Number: MS-1682
 Date: Wednesday, January 21, 2009 Sheet: 21 of 51

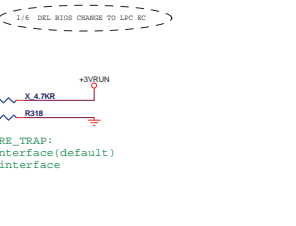
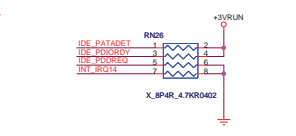
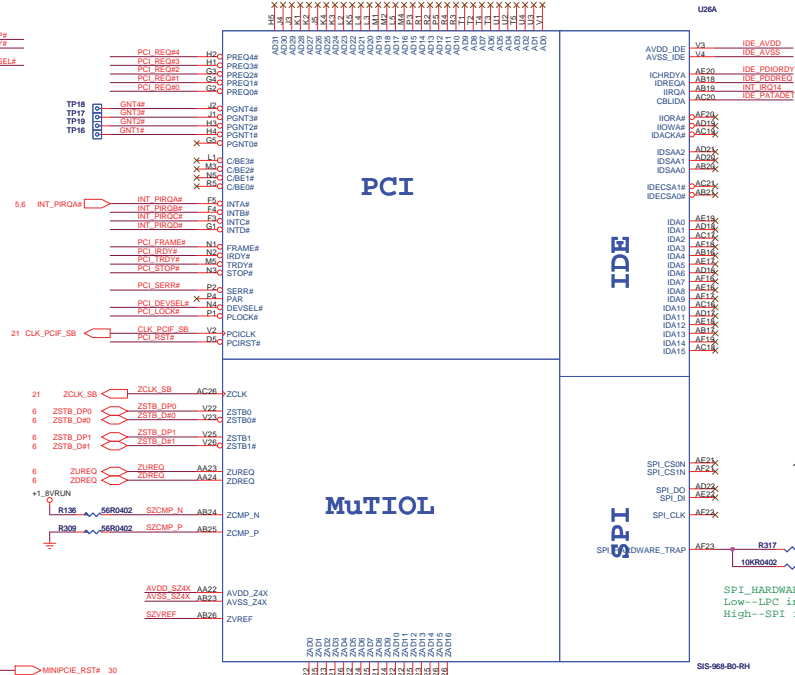
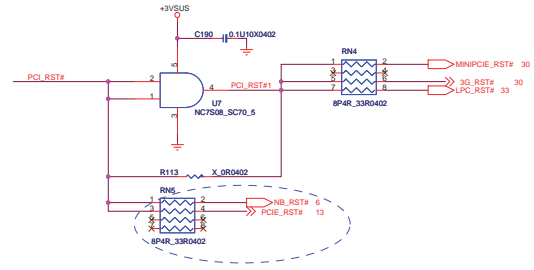
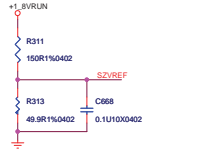
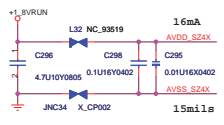
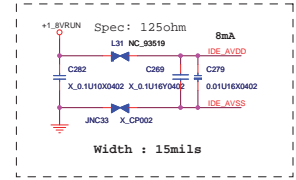
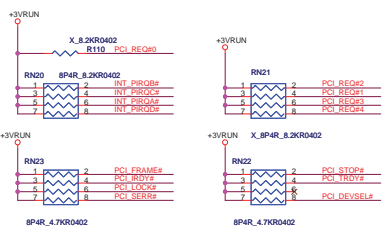

<http://laptop-motherboard-schematic.blogspot.com/>

MSI CORPORATION			
File		SIS968-1 (PCI/IDE/SPI/MultiIO)	
Size		E24 / M0	
Custom	Document Number	MS-1682	
Date	Wednesday, January 21, 2009	Sheet	22 of 61
		Rev	0A

USB 0 ,USB 0,2,4,5
 USB 1 ,USB 1,3,5,7

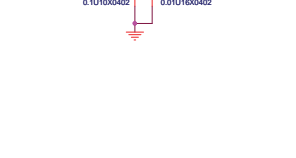
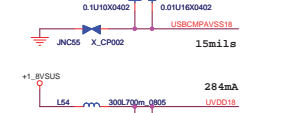
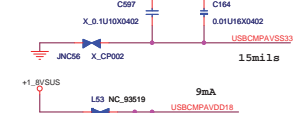
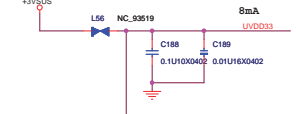
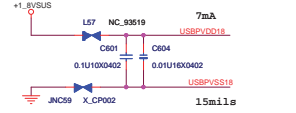
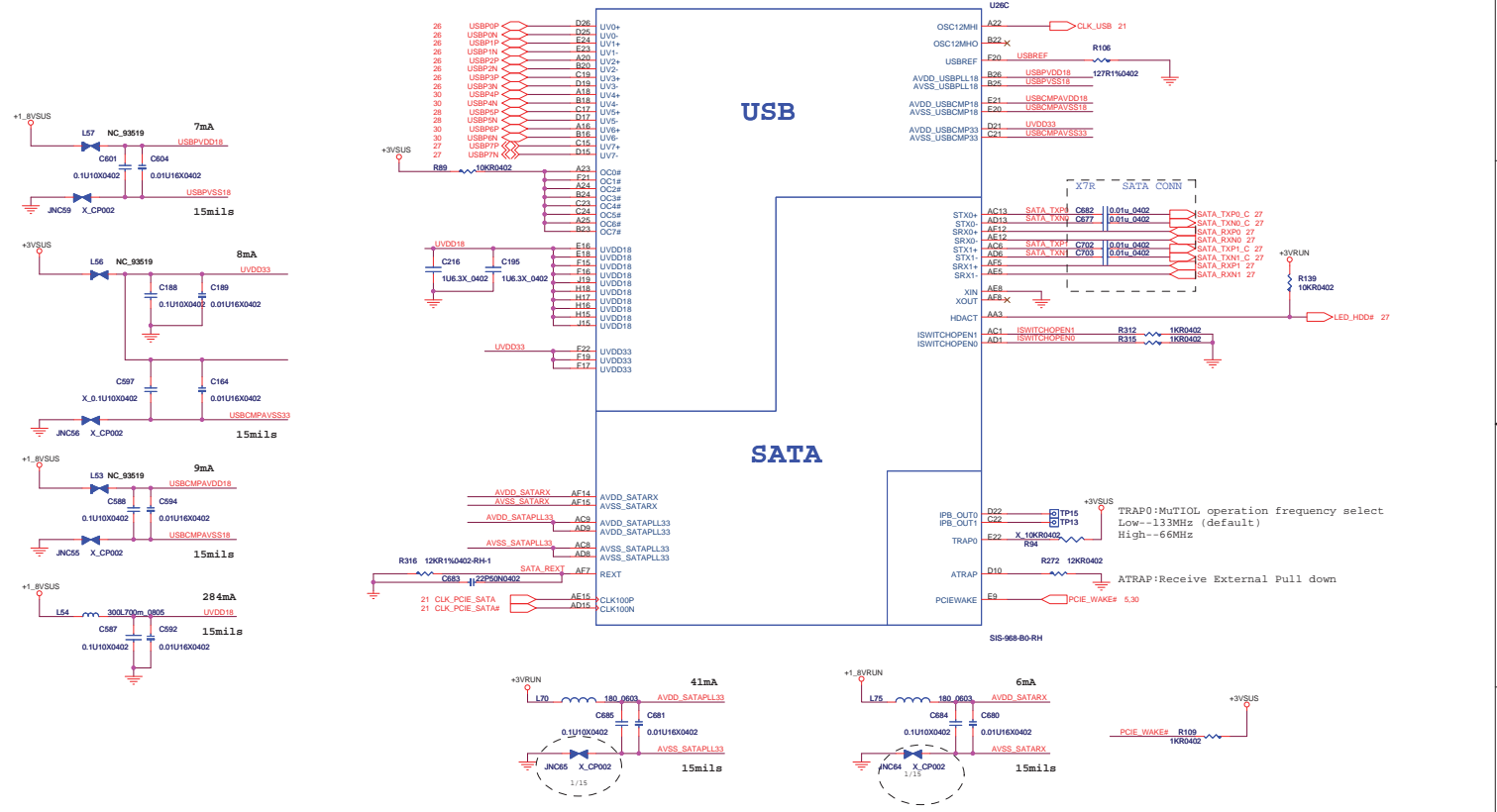

E32/M0

MSI CORPORATION		
File: SIS968-2 (USB/SATA)		
Size: Custom	Document Number: MS-1682	Rev: 0A
Date: Wednesday, January 21, 2009	Sheet: 23	of 51

<http://laptop-motherboard-schematic.blogspot.com/>

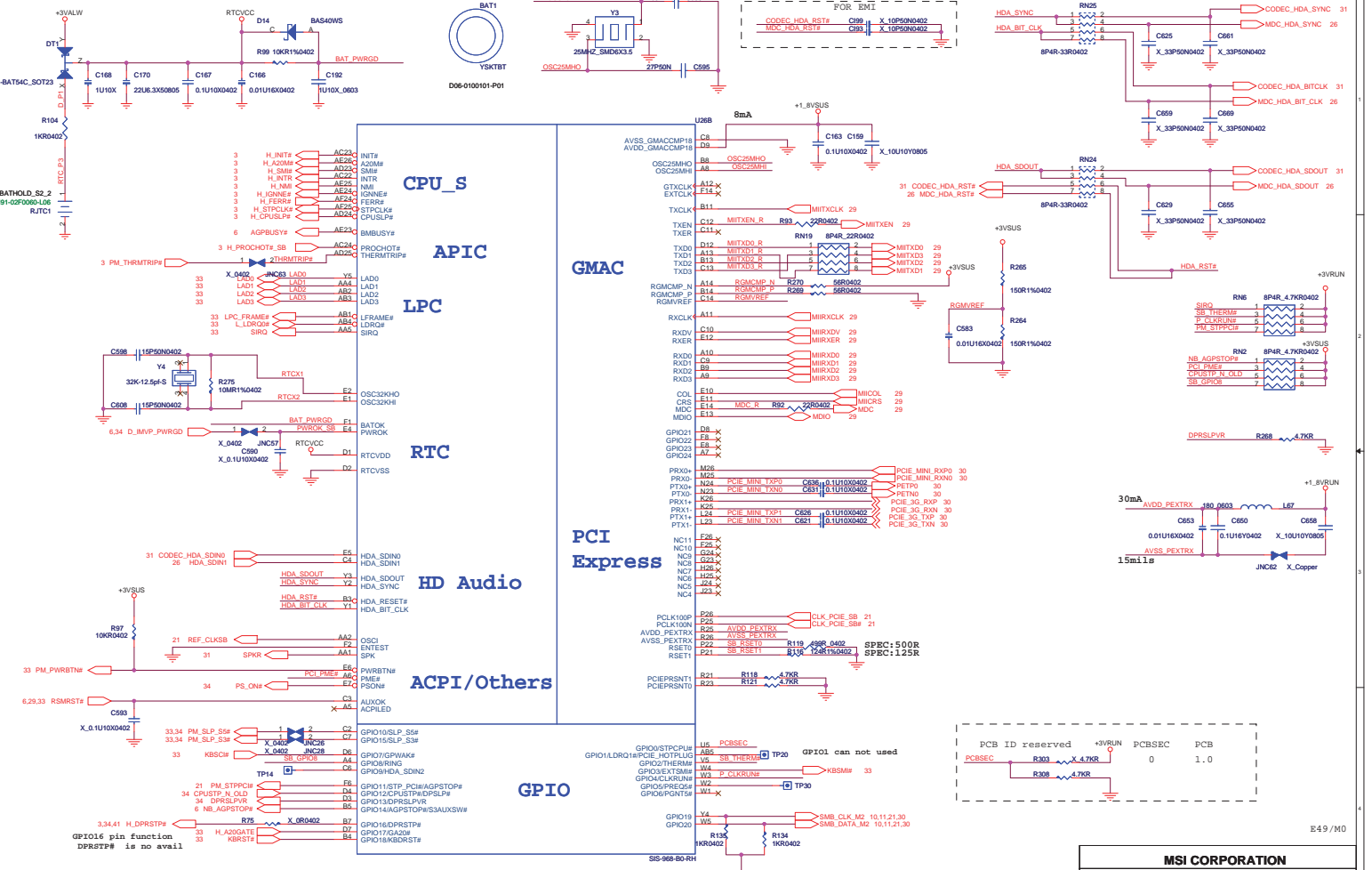

<http://laptop-motherboard-schematic.blogspot.com/>

MSI CORPORATION	
File	SIS968-3 (CPU/PCIE/GPIO)
Size	Document Number
Customer	MS-1682
Date	Wednesday, January 21, 2009 Sheet 24 of 51
Rev	0A

E49/90

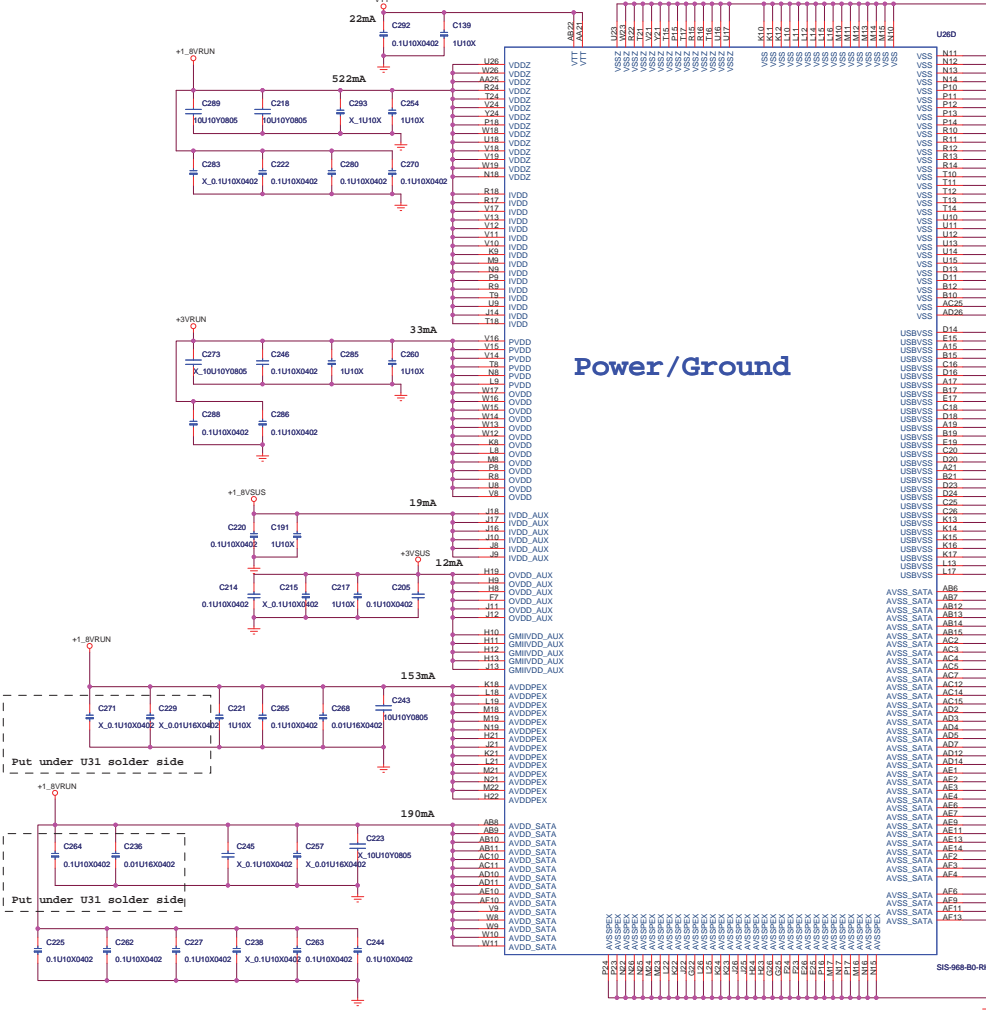

Power / Ground

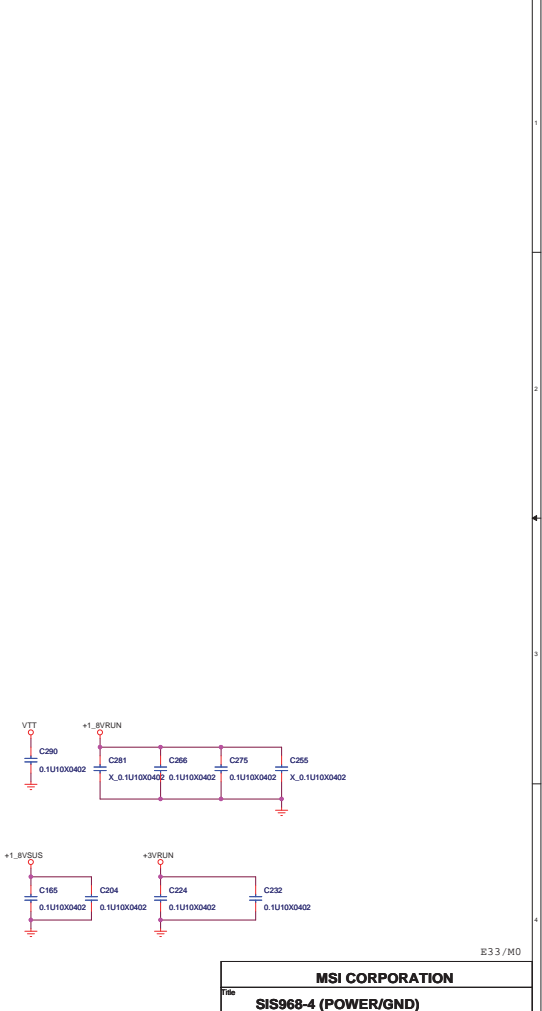
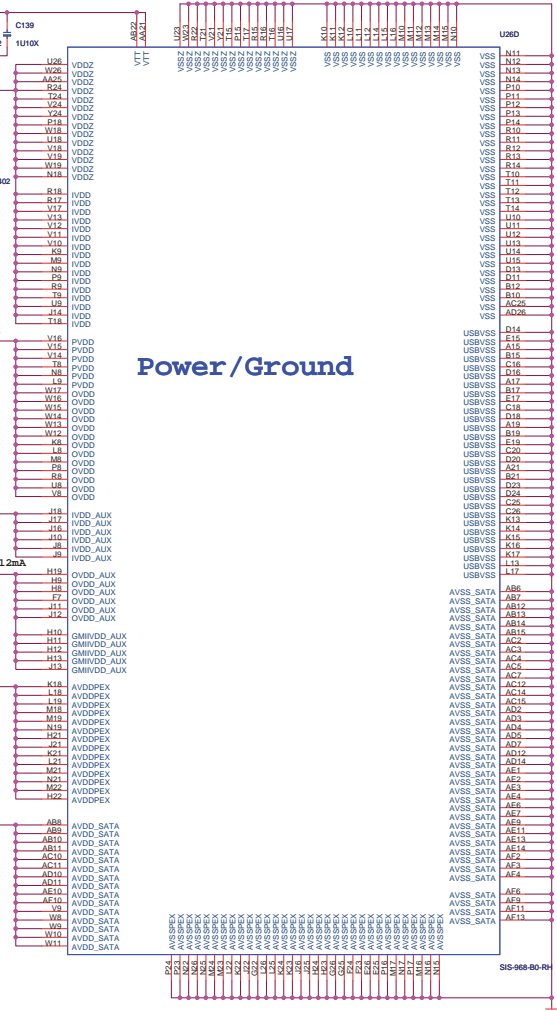

Put under U31 solder side

Put under U31 solder side

<http://laptop-motherboard-schematic.blogspot.com/>

MSI CORPORATION		
SIS968-4 (POWER/GND)		
Size	Document Number	Rev
Custom	MS-1682	0A
Date:	Wednesday, January 21, 2009	Sheet 25 of 51

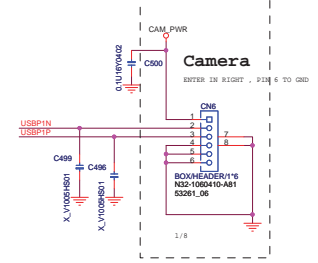
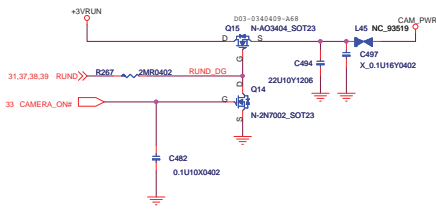
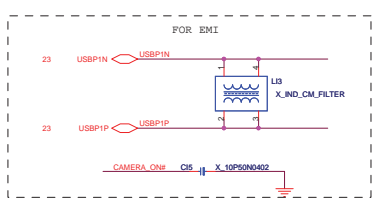
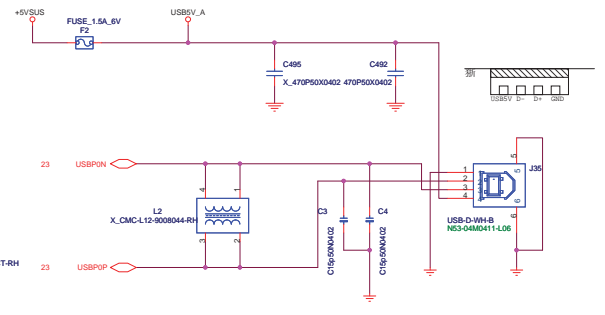
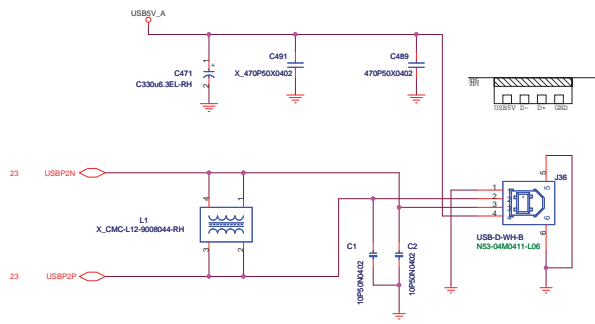

MDC Connector

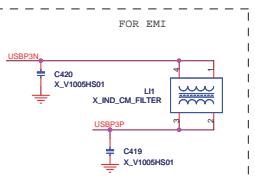
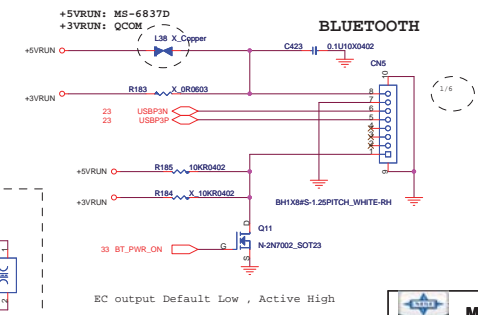
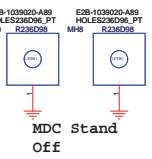
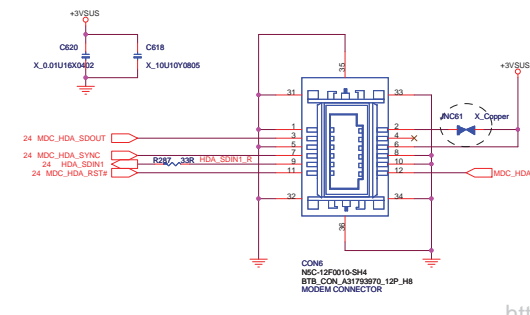

CONN: NDC-12F010-SH4
BTB_CON_A31793970_12P_H8
MDCM CONNECTOR

E19/M2

MICRO-STAR INT'L CO.,LTD.	
File	USBX2&Camera&MDC&BT CONN
Size	Document Number
Custom	MS-1682
Date	Wednesday, January 21, 2009 Sheet 26 of 51
Rev	0A

<http://lappp-math-hbnag-fschematic.blogspot.com/>

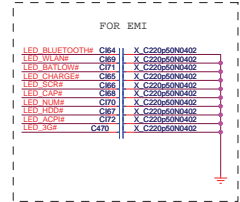
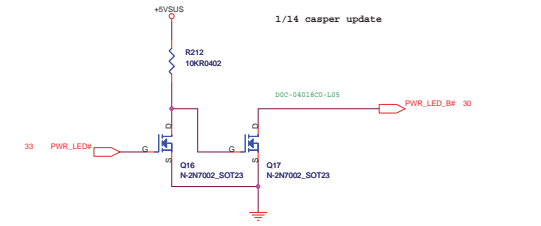
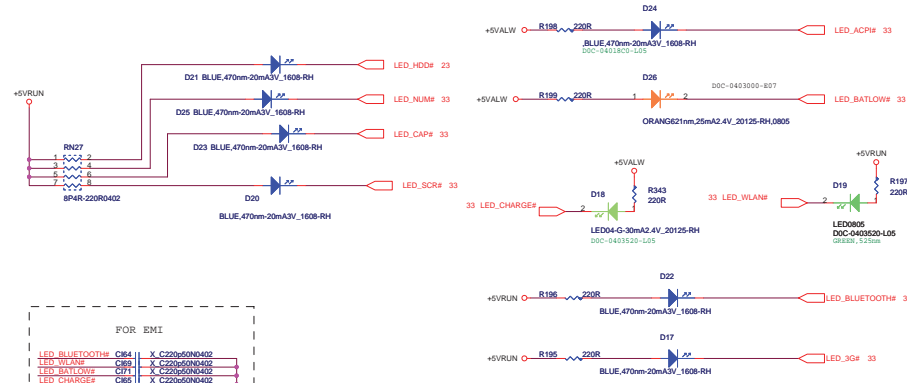
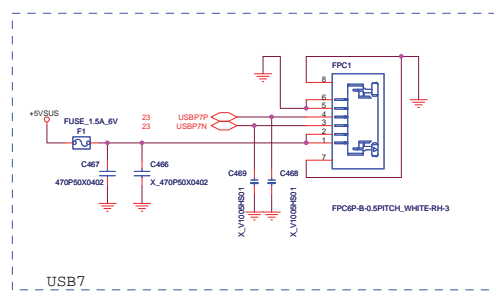
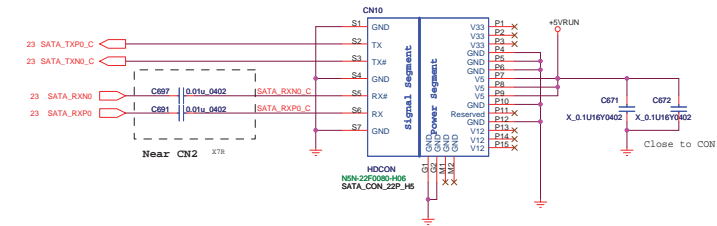
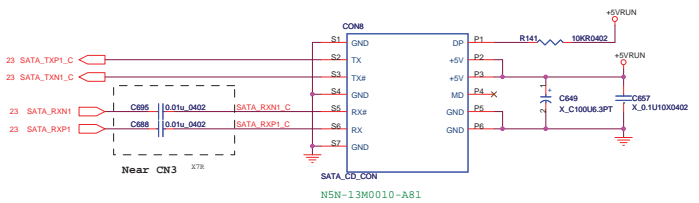
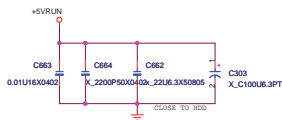

1/132 casper update

MICRO-STAR INT'L CO.,LTD.

File: **HDD & ODD CONN & USB7 & LED**

Size: Custom Document Number: **MS-1682**

Date: Wednesday, January 21, 2009 Sheet: 27 of 51

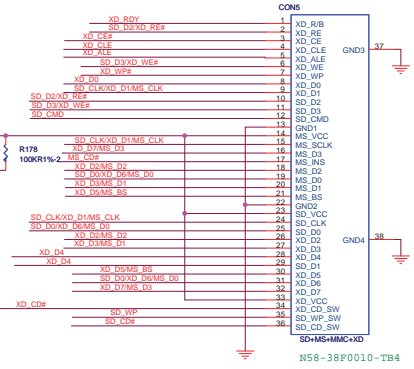
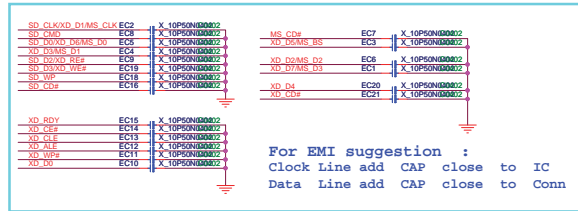
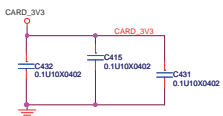
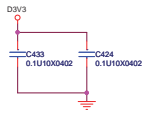
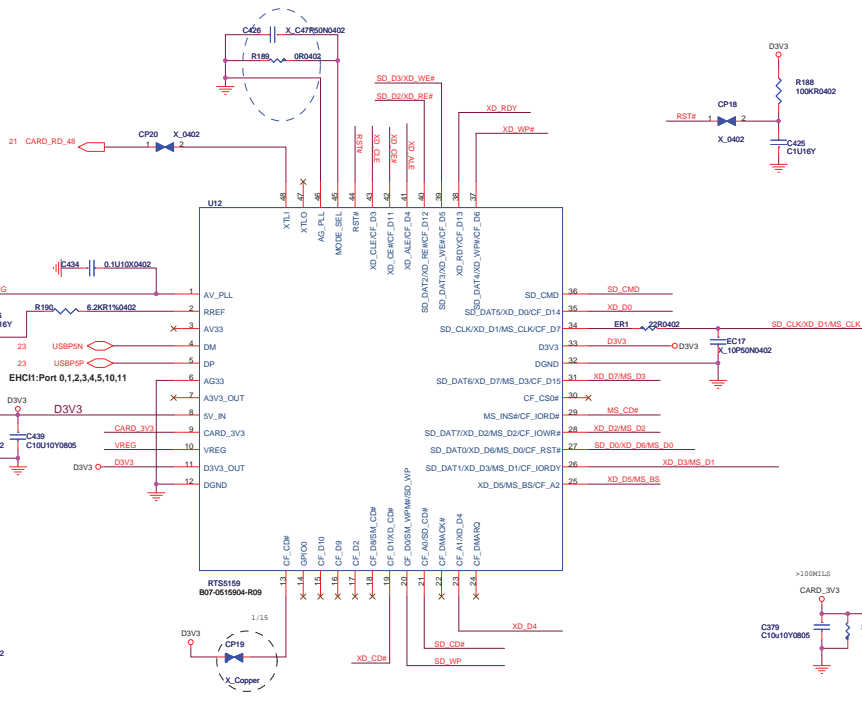
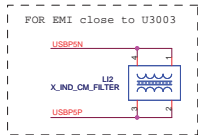

MICRO-STAR INT'L CO.,LTD.

File: **RTS5158E_CARD READER**

Size: Document Number: **MS-1682**

Date: Wednesday, January 21, 2009 Sheet: 28 of 51

LAN MAGNETICS

PWFBOUT R156 050603 V_DAC

1/12 casper update

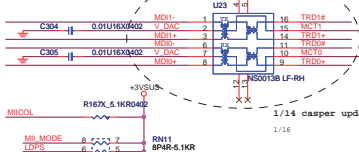
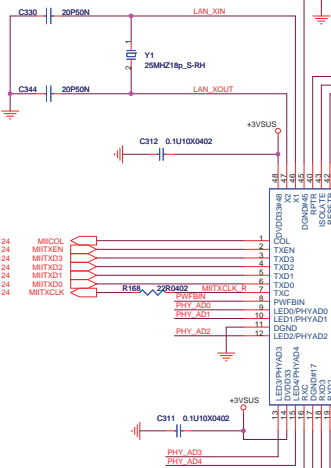

1/14 casper update

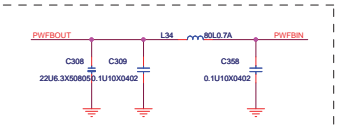
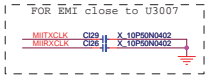
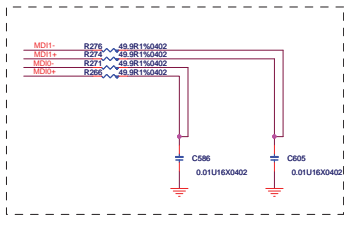

please C308,C309,L307 close to PWFBOU(U3007.32) and C309 close to PWFBI(U3007.8)

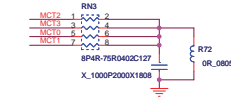
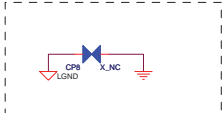
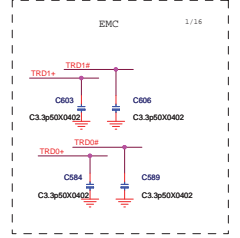
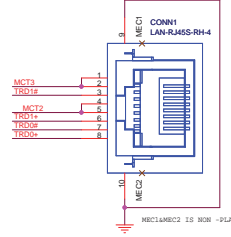
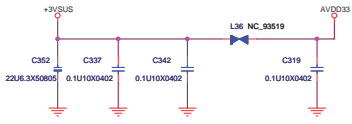

MICRO-STAR INT'L CO.,LTD.			
File		PHY LAN (RTL8201CL) E37/M0	
Size	Document Number	MS-1682	
Customer	Rev	0A	
Date	Wednesday, January 21, 2009	Sheet	25 of 51

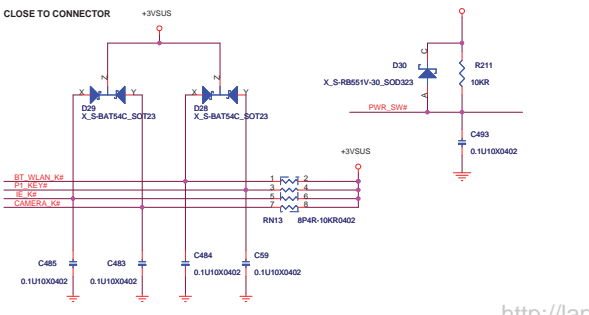
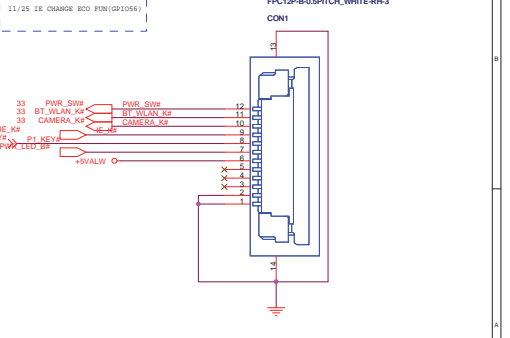
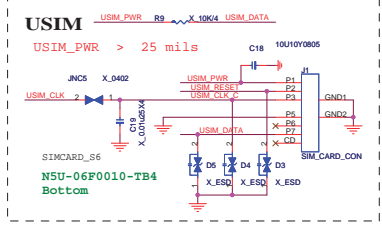
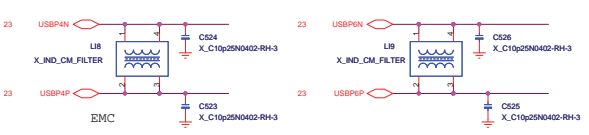
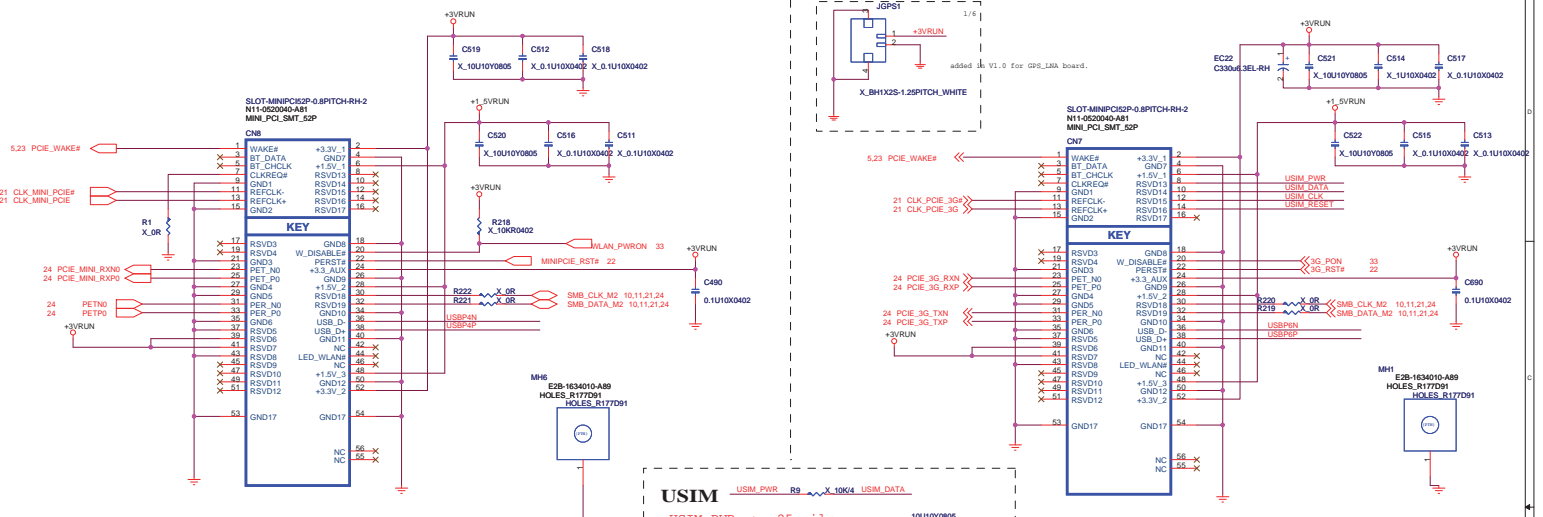

1/12 casper update

MICRO-STAR INT'L CO.,LTD.
MINI_PCIE & LED & SW
 Size Custom Document Number MS-1682 Rev 0A
 Date Wednesday, January 21, 2009 Sheet 30 of 51

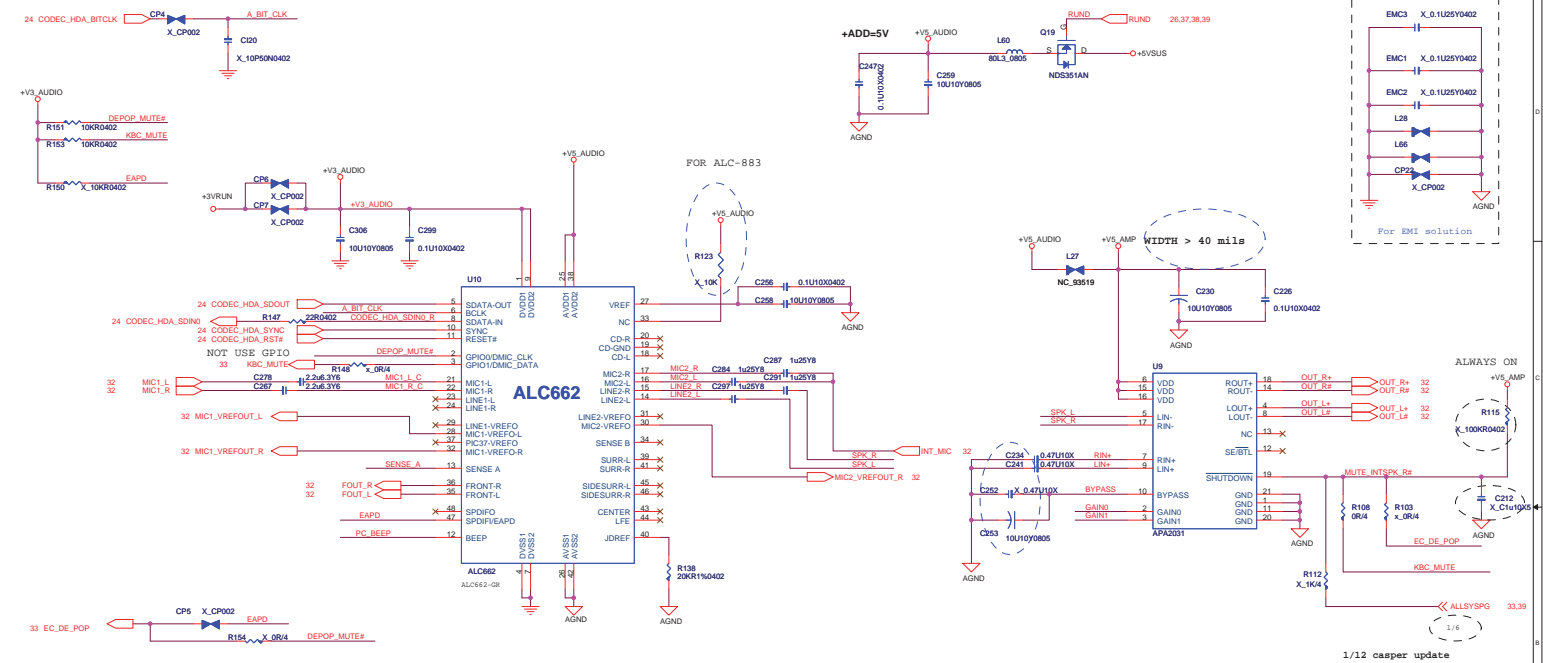

For APA2031			For FAN7031		
Av	GAIN0	GAIN1	Av	GAIN0	GAIN1
6dB	0	0	6dB	0	0
10dB	0	1	10dB	0	1
15.6dB	1	0	15.6dB	1	0
21.6dB	1	1	21.6dB	1	1
4.3dB	X	X	4.3dB	X	X

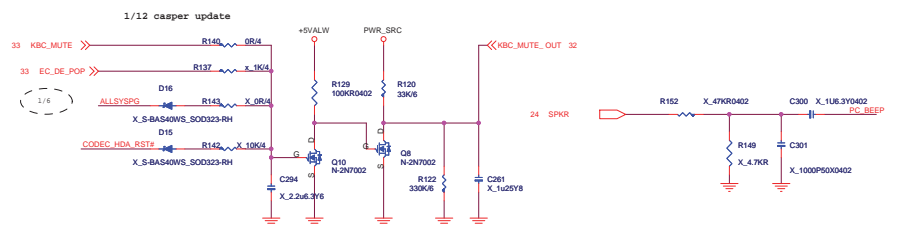
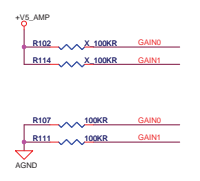

<http://laptop-motherboard-schematic.blogspot.com/>

E37/MD

MICRO-STAR INT'L CO., LTD.

File: **AUDIO(ALC888) + AMP(APA2031)**

Size: **MS-1682**

Date: Wednesday, January 21, 2009 Sheet: 31 of 51

1/20 EAPD DELAY 650ms

HP IN IS LOW

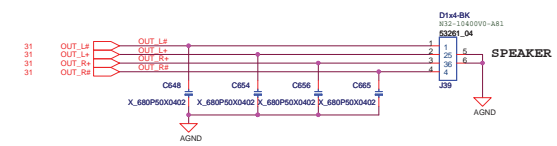
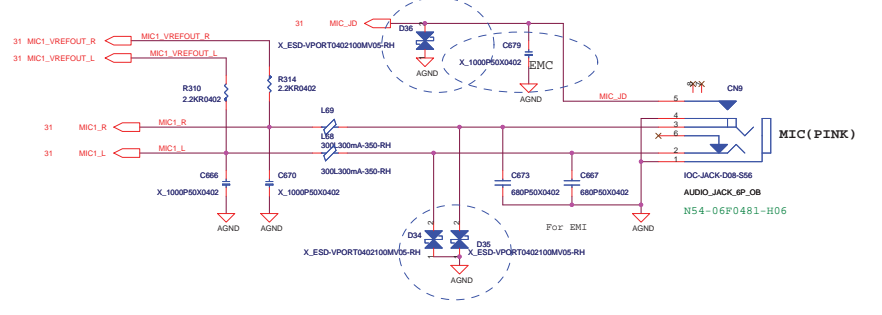
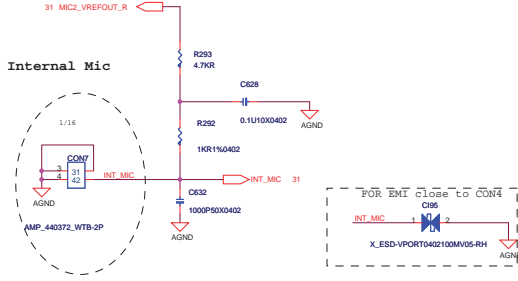
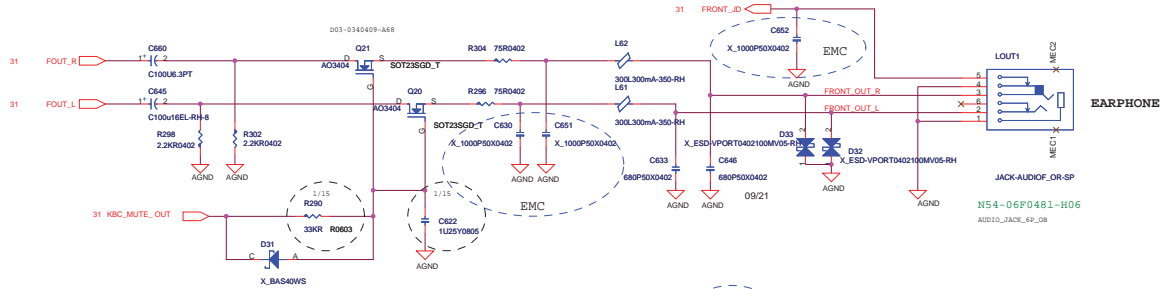

MICRO-STAR INT'L CO.,LTD.			
Title		SPK / HP / MIC	
Size	Document Number	E2B / M0	
Customer	MS-1682	Rev 0A	
Date	Wednesday, January 21, 2009	Sheet	32 of 51

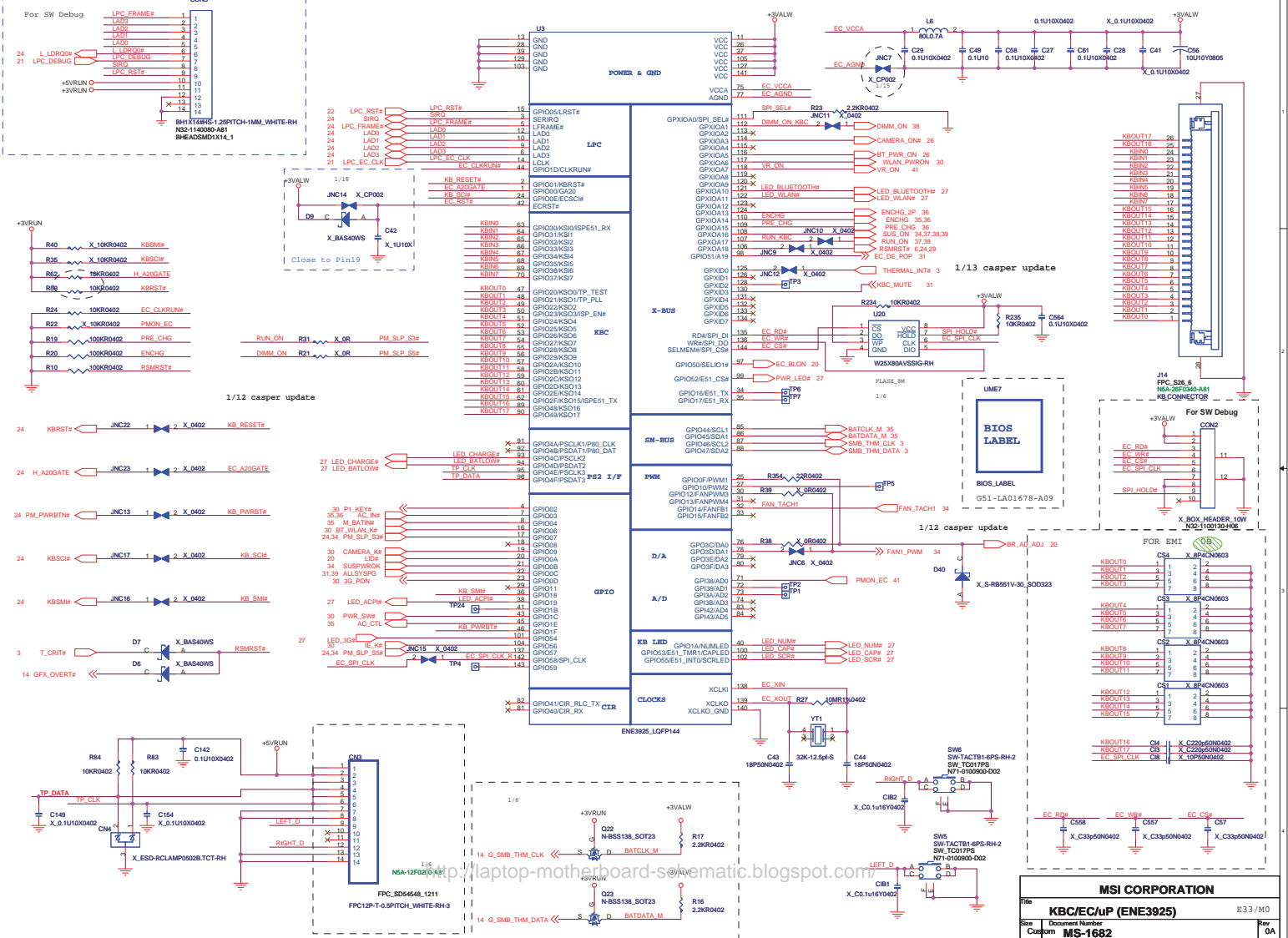

MSI CORPORATION		
File	Document Number	B33/M0
Customer	MS-1682	Rev 0A
Date	Wednesday, January 21, 2009	Sheet 33 of 61

VCCFAN1=1.6+FAN1_PWM

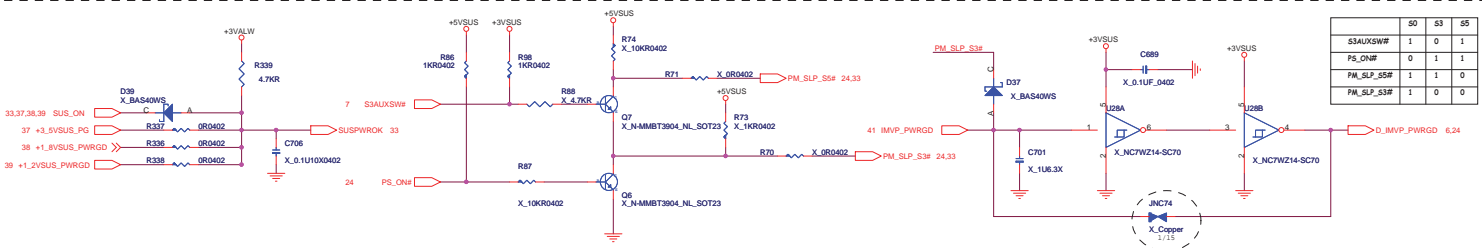
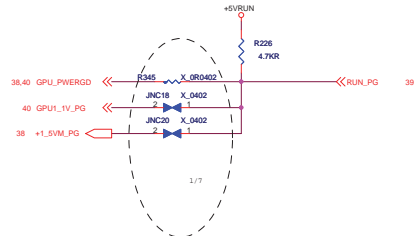
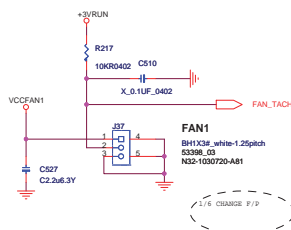
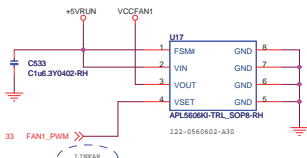

	S0	S3	S5
S3AUXSW#	1	0	1
PS_ON#	0	1	1
PM_SLP_S5#	1	1	0
PM_SLP_S3#	1	0	0

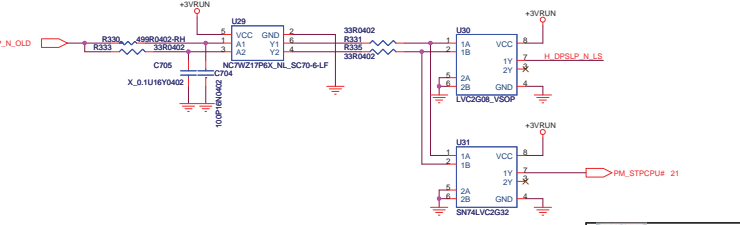
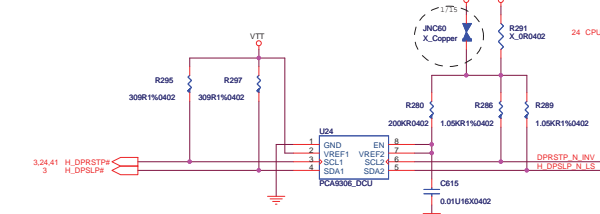
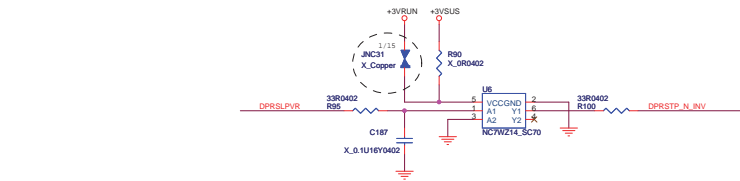
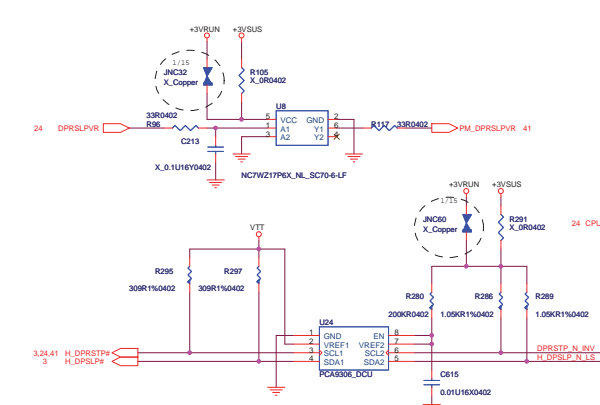

MICRO-STAR INT'L CO.,LTD.

Title: **PWRGD & FAN & C3/C4** E33 / M0

Size: Custom Document Number: **MS-1682** Rev: 0A

Date: Wednesday, January 21, 2009 Sheet: 34 of 51

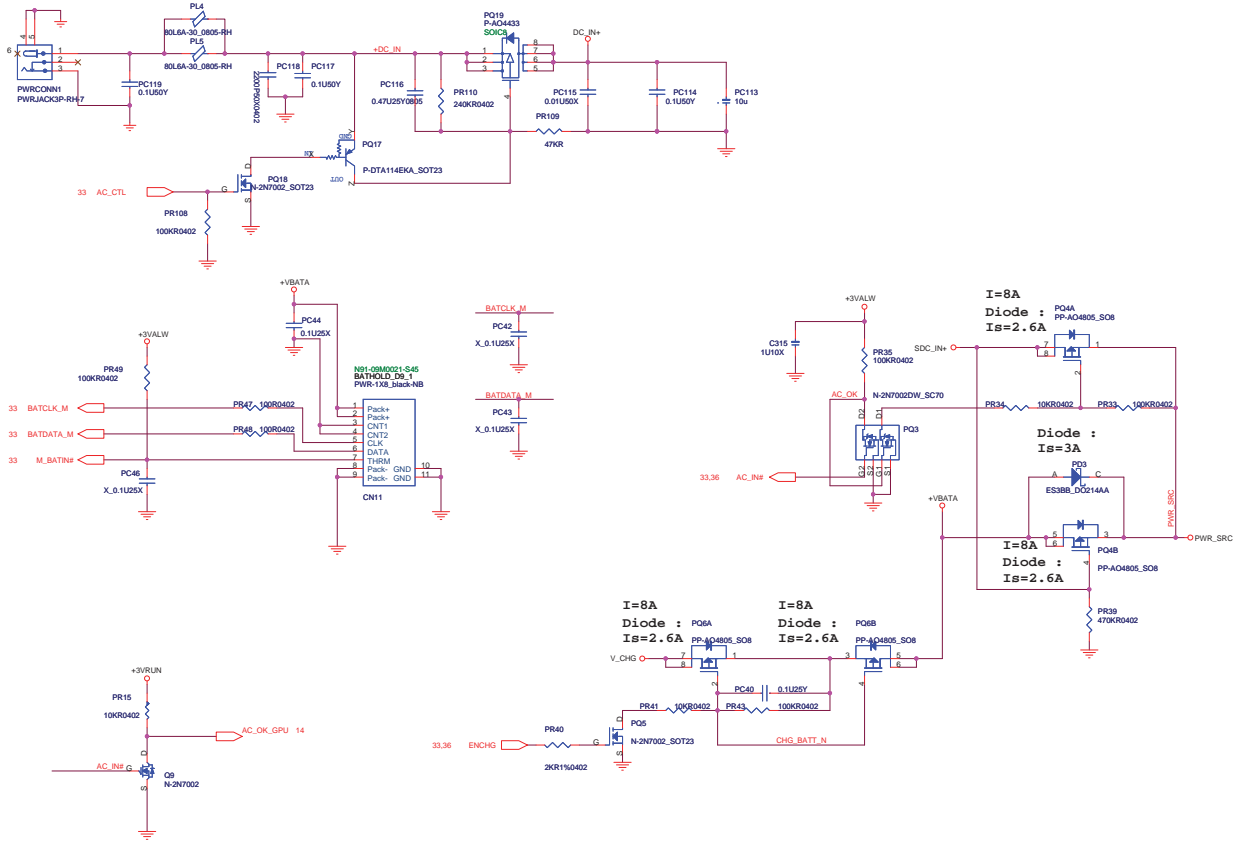

<http://laptop-motherboard-schematic.blogspot.com/>

 MICRO-STAR INT'L CO.,LTD.	
Title	E39 / M0
Battery select	
Size	10
Customer	MS-1682
Date	Wednesday, January 21, 2009 Sheet 35 of 51

Adapter= 90 W $2.048/7.15*(53.6+7.15)=17.4V$
 Adapter input voltage set 17.4 Voltage

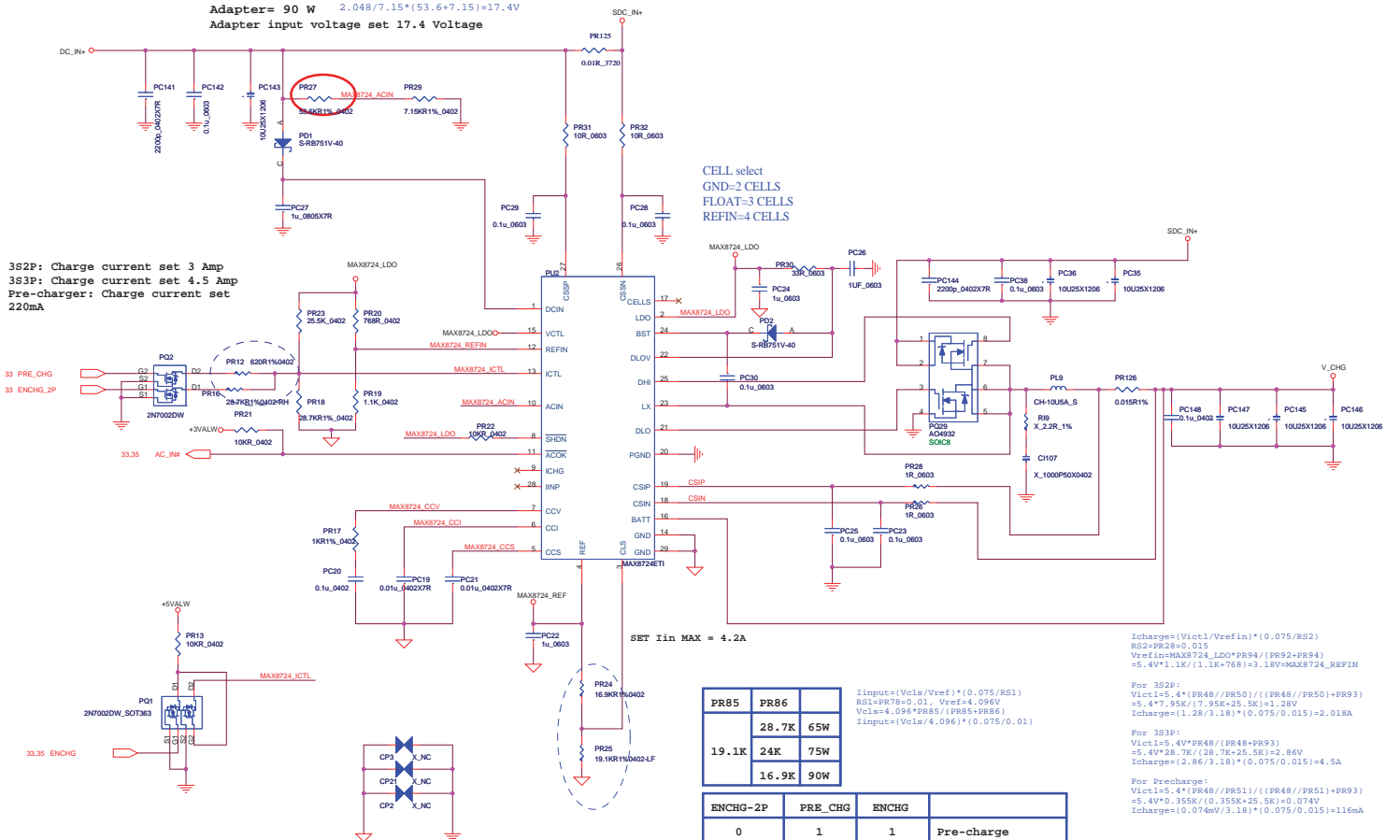

3S2P: Charge current set 3 Amp
 3S3P: Charge current set 4.5 Amp
 Pre-charger: Charge current set 220mA

CELL select
 GND=2 CELLS
 FLOAT=3 CELLS
 REFIN=4 CELLS

SET Iin MAX = 4.2A

FR85	FR86	
19.1K	28.7K	65W
	24K	75W
	16.9K	90W

$I_{in} = (V_{in}/V_{ref}) * (0.075/RS1)$
 $RS1 = PR78 = 0.01$, $V_{ref} = 1.096V$
 $V_{in} = 4.096 * PR85 / (PR85 + PR86)$
 $I_{in} = (V_{in}/4.096) * (0.075/0.01)$

$I_{charge} = (V_{ict1}/V_{refin}) * (0.075/RS2)$
 $RS2 = PR28 = 0.015$
 $V_{refin} = MAX8724_LDO_PR94 / (PR92 + PR94) = 5.4V * 1.1K / (1.1K + 768) = 3.18V = MAX8724_REFIN$
 For 3S2P:
 $V_{ict1} = 5.4 * (PR48 / PR50) / ((PR48 / PR50) + PR93) = 5.4 * 7.95K / (7.95K + 25.5K) = 1.28V$
 $I_{charge} = (1.28 / 3.18) * (0.075 / 0.015) = 2.018A$
 For 3S3P:
 $V_{ict1} = 5.4 * PR48 / (PR48 + PR93) = 5.4V * 7.95K / (7.95K + 25.5K) = 1.28V$
 $I_{charge} = (2.86 / 3.18) * (0.075 / 0.015) = 4.5A$
 For Precharge:
 $V_{ict1} = 5.4 * (PR48 / PR51) / ((PR48 / PR51) + PR93) = 5.4V * 0.355K / (0.355K + 25.5K) = 0.074V$
 $I_{charge} = (0.074mV / 3.18) * (0.075 / 0.015) = 116mA$

ENCHG-2P	PRE_CHG	ENCHG	
0	1	1	Pre-charge
1	0	1	3S2P-Fast charge
0	0	1	3S3P-Fast charge
0	0	0	STOP CHARGE

MICRO-STAR INT'L CO.,LTD.
 File: **Battery Charger** E51/M0
 Size: Custom Document Number: MS-1682 Rev: 10
 Date: Wednesday, January 21, 2009 Sheet: 35 of 51

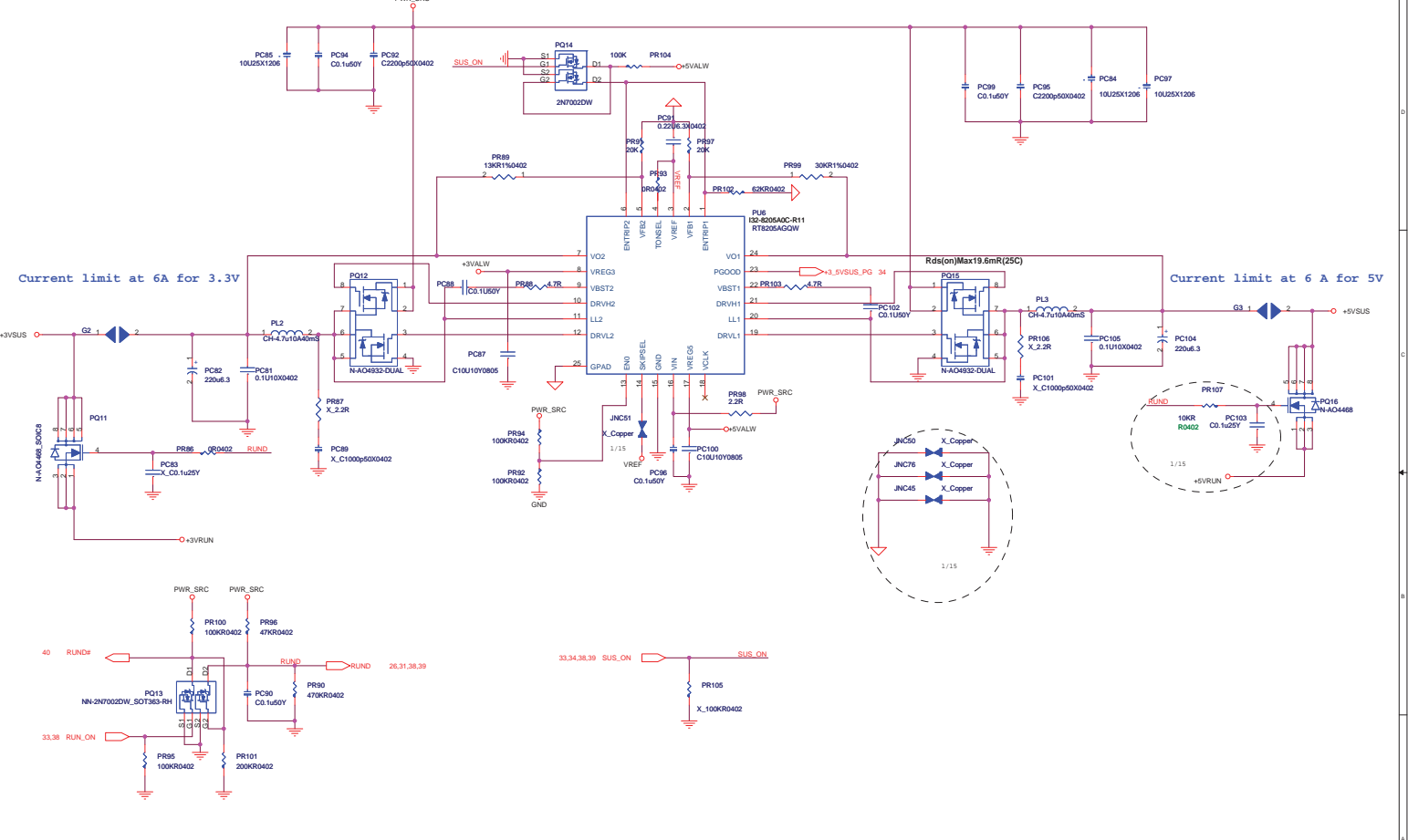

MSI CORPORATION			
File	SYSTEM POWER	B:46 / M:0	
Size	Document Number	10	
Custom	MS-1682	Rev	
Date	Wednesday, January 21, 2009	Sheet	37 of 51

<http://laptop-motherboard-schematic.blogspot.com/>

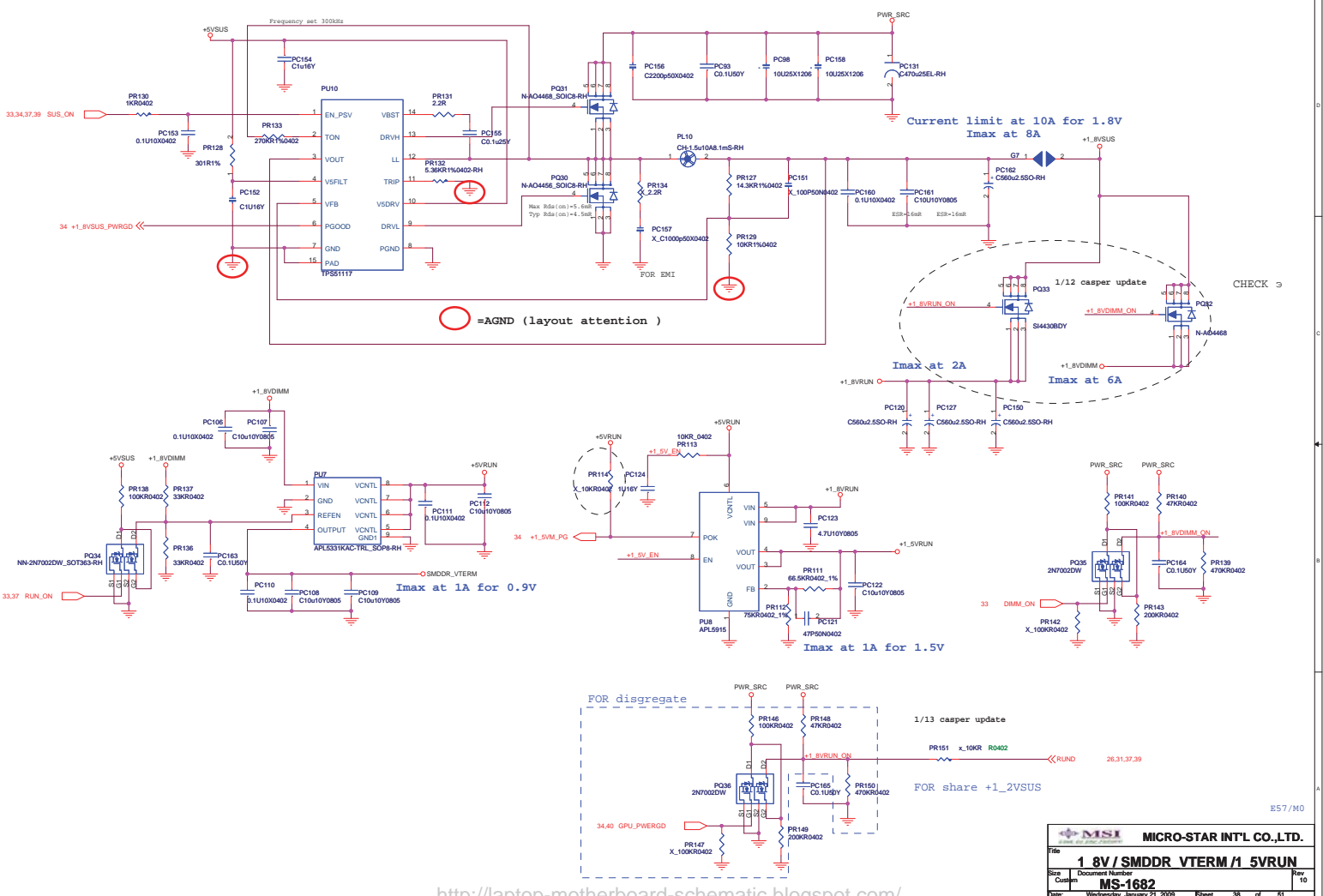

B57/M0

MSI MICRO-STAR INT'L CO.,LTD.	
File	1.8V / SMDR_VTERM / 1.5VRUN
Size	Document Number
Customer	MS-1682
Date	Wednesday, January 21, 2009
Sheet	33 of 51
Rev	10

<http://laptop-motherboard-schematic.blogspot.com/>

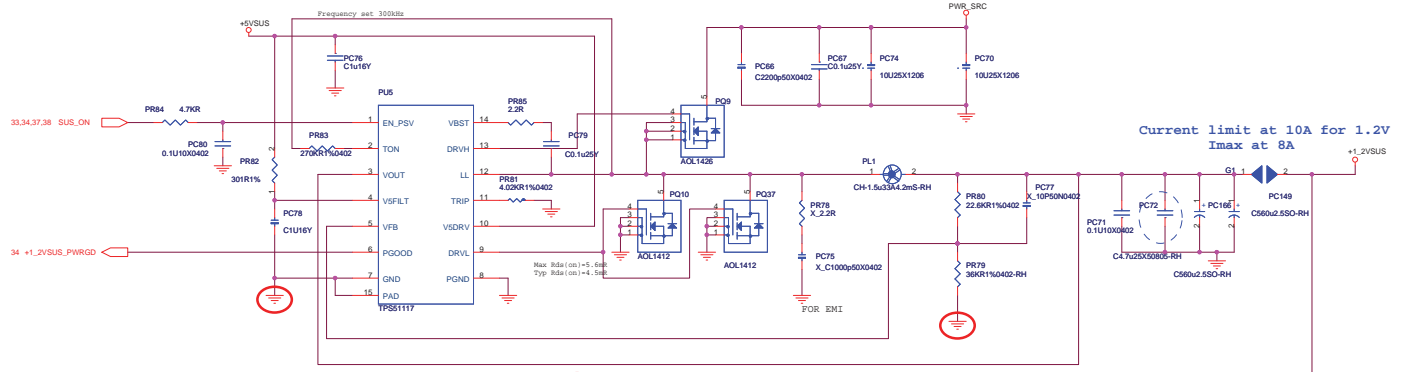

○ =AGND (layout attention)

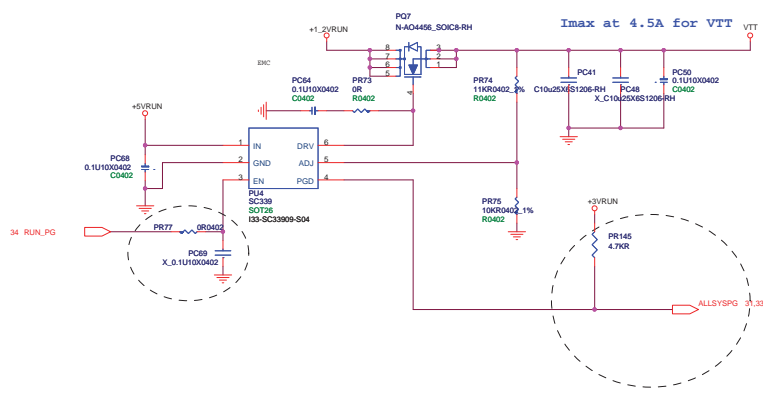
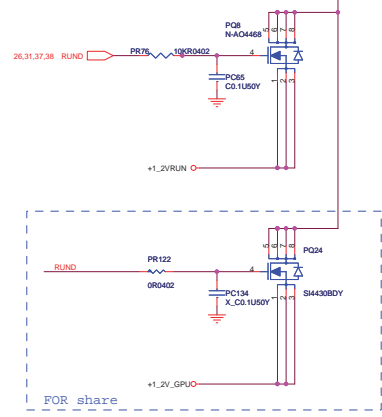

MSI		MICRO-STAR INT'L CO.,LTD.	
Title	1.2V & VTT		E3B/M0
Size	Document Number		Rev
Custom	MS-1682		10
Date	Wednesday, January 21, 2009		Sheet 93 of 91

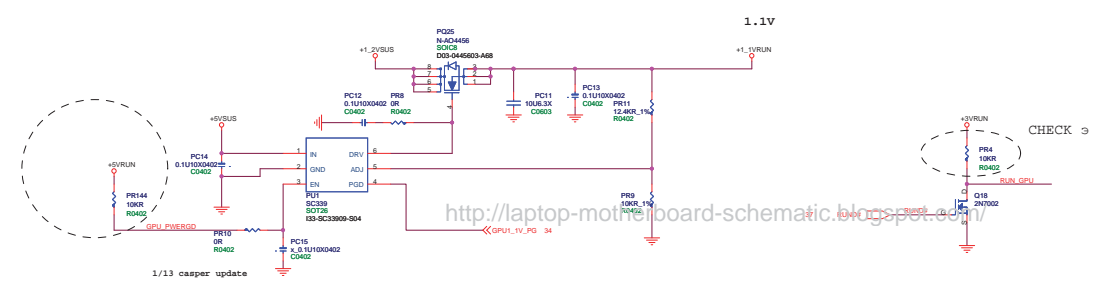
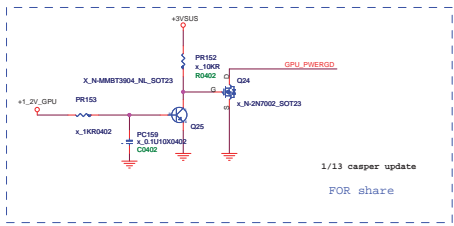
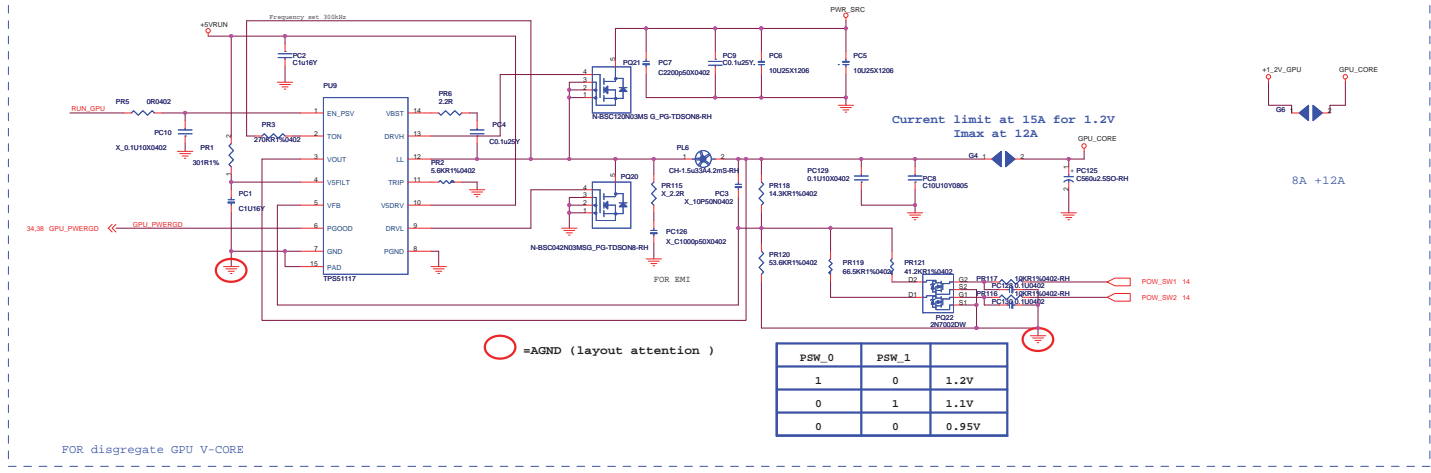

File	<Title>	E417/M0
Size	Document Number	M5-1682
C	Rev	<Rev>
Date	Wednesday, January 21, 2009	Page 40 of 51

1/14 casper update

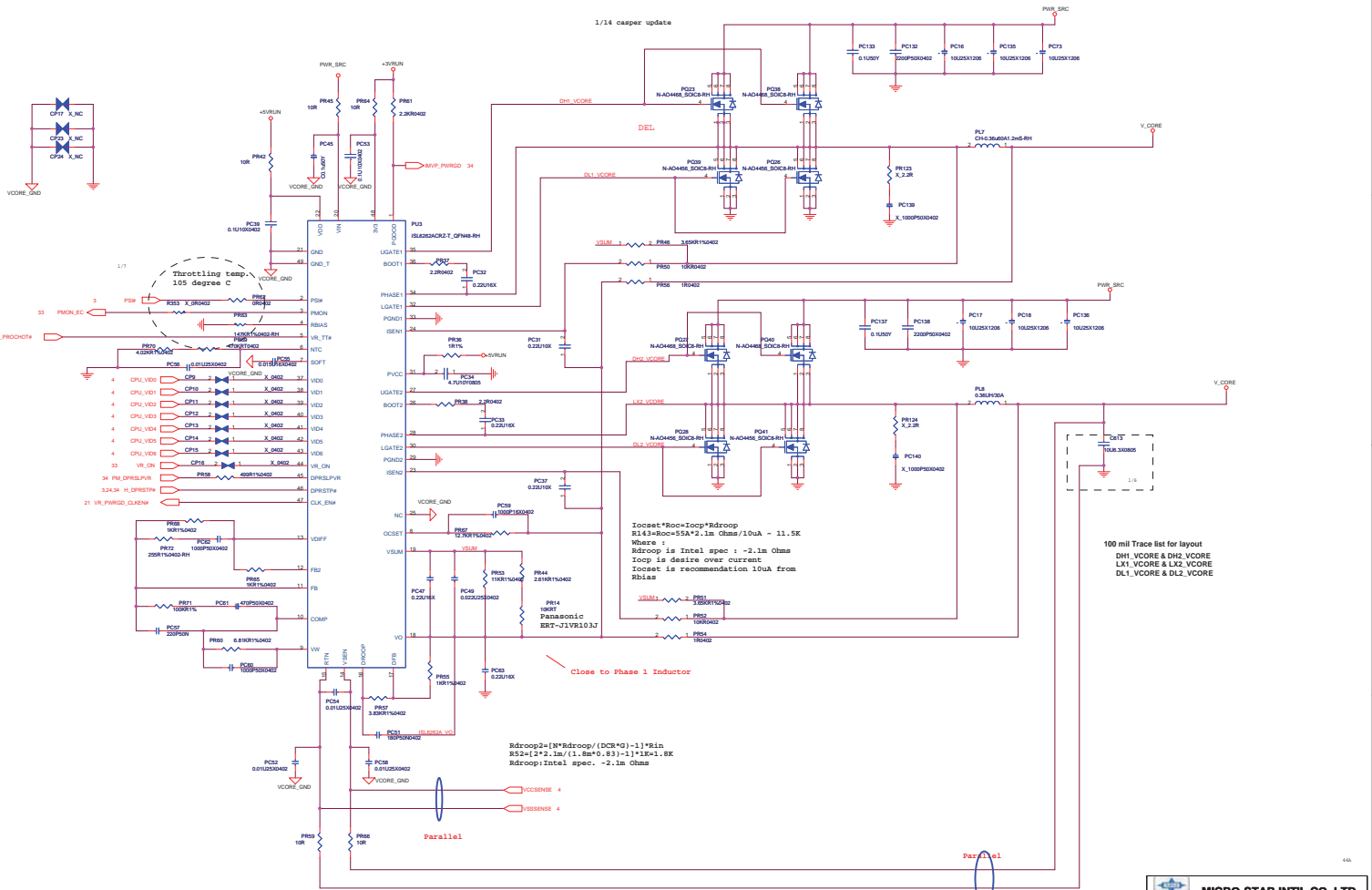

Throttling temp.
105 degree C

Induct=800*Ioop*Rdroop
R143=800=55A*2.1m Ohms/10uA = 11.5K
Where :
Rdroop is Intel spec = 2.1m Ohms
Ioop is desire over current
Induct is recommendation 10uA from
BIOS

Rdroop2=(N*Rdroop)/(DCR*Q)-1)*Rin
R224=(2*1m/(1.1*55*0.83))-1)*115m Ohms
Rdroop: Intel spec = 2.1m Ohms

100 mil Trace list for layout
DH1_VCORE & DH2_VCORE
LX1_VCORE & LX2_VCORE
DL1_VCORE & DL2_VCORE

<http://laptop-motherboard-schematic.blogspot.com/>

MICRO-STAR INT'L CO., LTD.
CPU POWER
MS-1682
Date: 2009-08-19

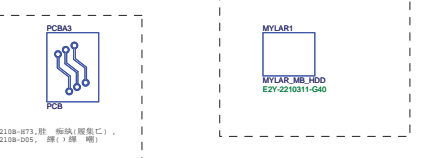
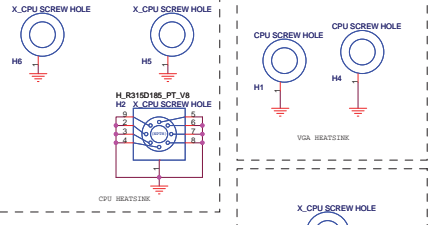
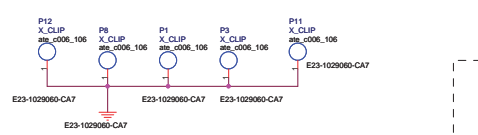
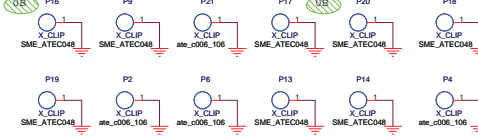
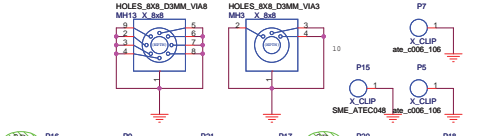
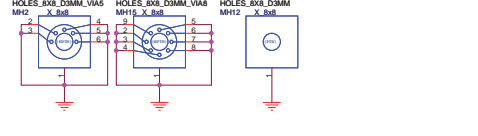
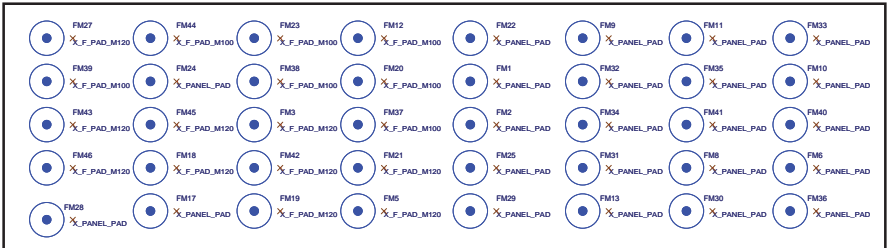
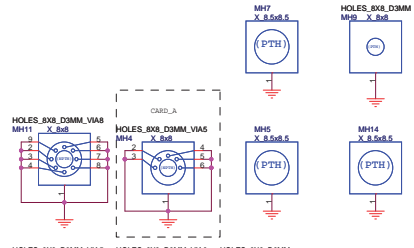

P30-1682128-H73, 註: 係換(原包C) -
P30-1682128-D05, 註: 係(原)期

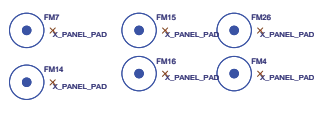

MSI		MICRO-STAR INT'L CO.,LTD.	
File	Screw	Document Number	B2/M2
Size	Custom	Document Number	MS-1682
Date	Wednesday, January 21, 2009	Sheet	42 of 51
		Rev	0A

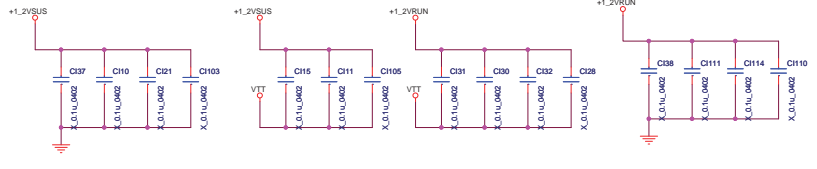
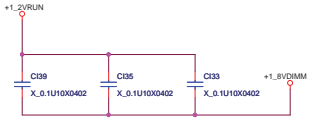
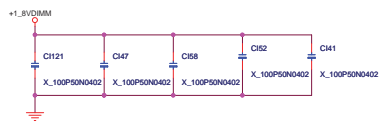
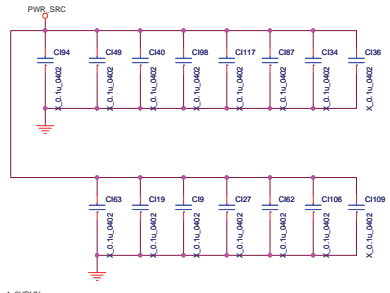
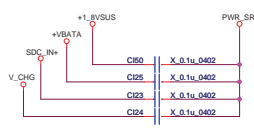
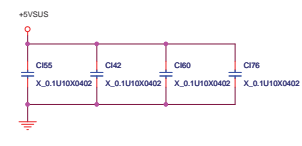
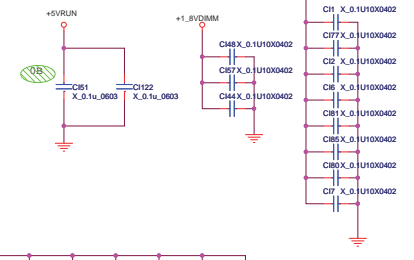
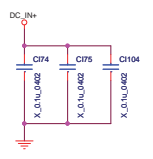
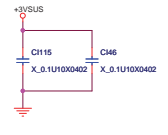
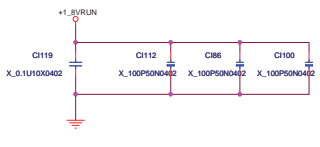
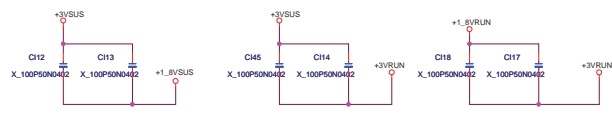
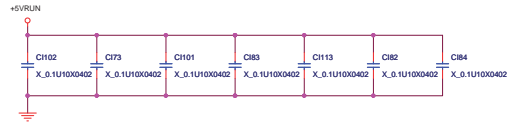
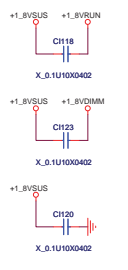
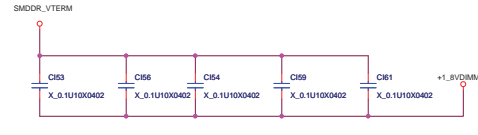
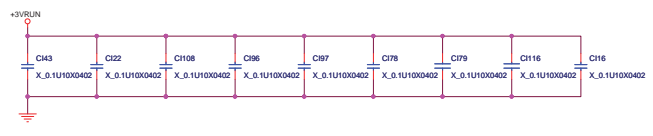

MICRO-STAR INT'L CO.,LTD.

File: **FMI**

Size: Custom

Document Number: **MS-1682**

Date: Wednesday, January 21, 2009

Sheet: 43 of 51

Rev: 0A

<http://laptop-motherboard-schematic.blogspot.com/>

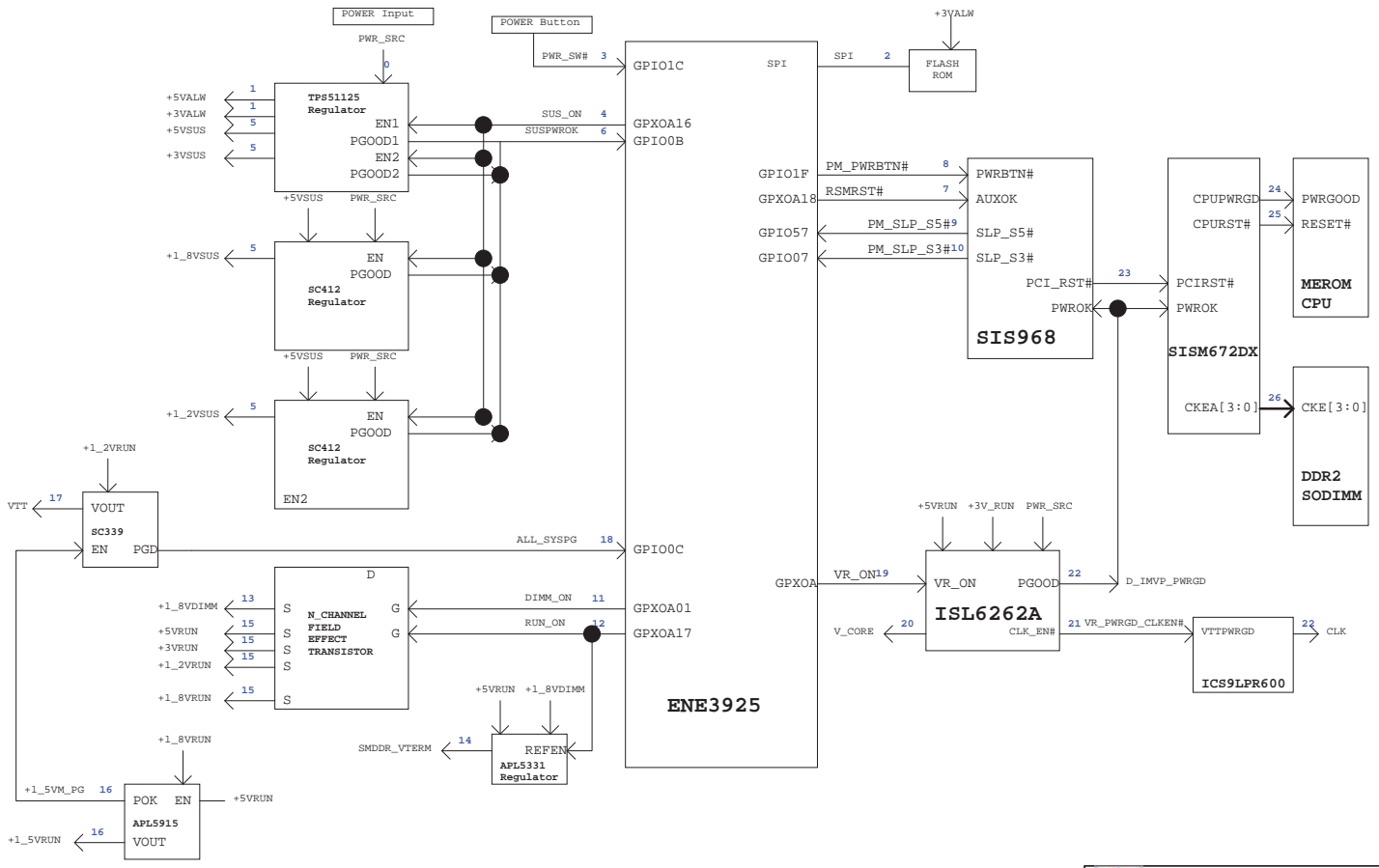

<http://laptop-motherboard-schematic.blogspot.com/>

MICRO-STAR INT'L CO.,LTD.			
File	Power Sequency-1		
Size	Document Number	Rev	
Custom	MS-1682	0A	
Date	Wednesday, January 21, 2009	Sheet	44 of 51

AC S5-S0
 EC programming timing
 SISM672FX + 968 timing SPEC

AC S0-S5
 EC programming timing
 SISM672FX + 968 timing SPEC

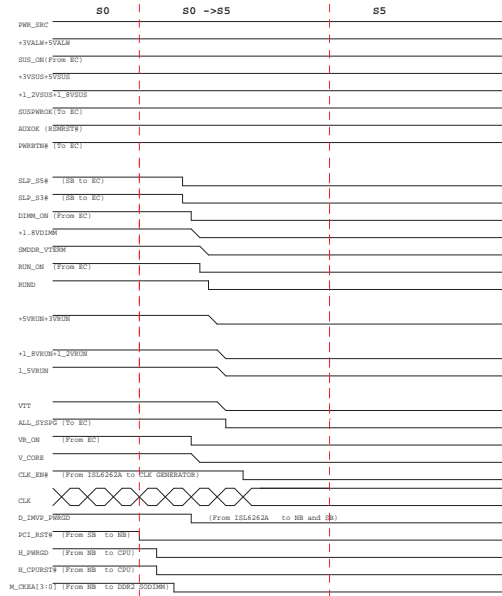
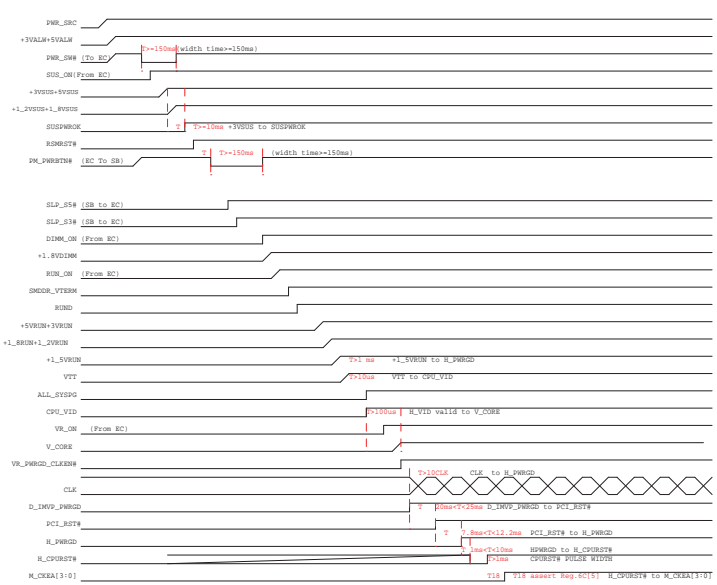

<http://laptop-motherboard-schematic.blogspot.com/>

 MICRO-STAR INT'L CO.,LTD.	
Power Sequence-2	
File	Document Number
Size	MS-1682
Date	Wednesday, January 21, 2009
Sheet	45 of 51
Rev	0A

AC S0-S3-S0
 EC programming timing
 SIM672FX + 968 timing SPEC

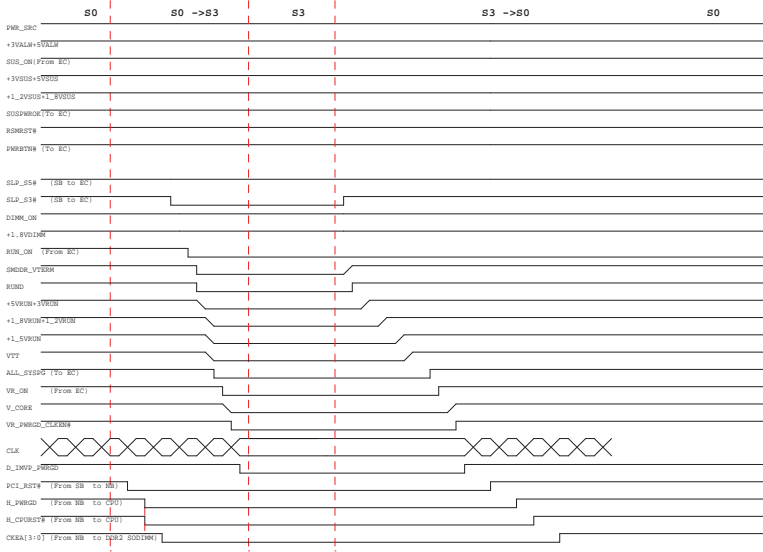

<http://laptop-motherboard-schematic.blogspot.com/>

		MICRO-STAR INT'L CO.,LTD.	
Title Power Sequence-2			
Size	Document Number	Rev	
Custom	MS-1682	0A	
Date	Wednesday, January 21, 2009	Sheet	46 of 51

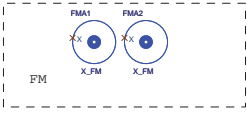
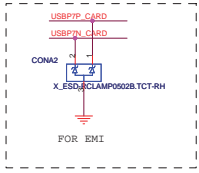
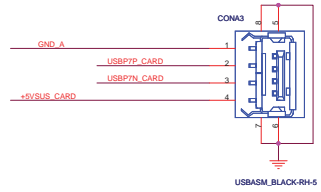
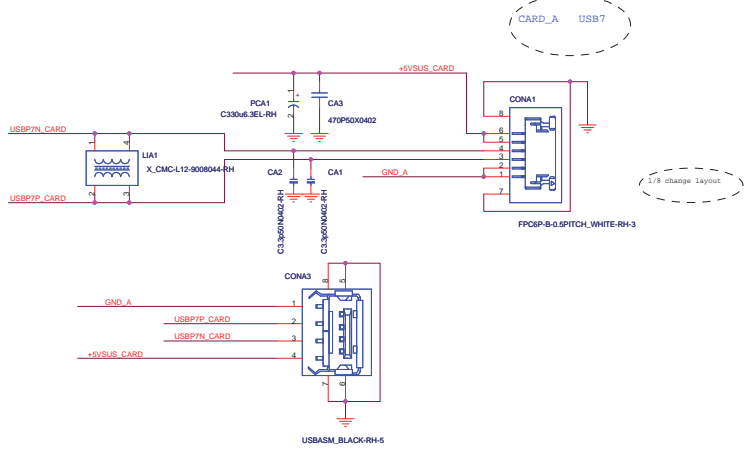

P30-1682A0B-H73, 胜 痲缺(履集亡)
 P30-1682A0B-D05, 纒()纒 喇),

<http://laptop-motherboard-schematic.blogspot.com/>

 MICRO-STAR INT'L CO.,LTD.	
Title	E5/M0
USB Board	
Size	Document Number
Customer	MS-16821A
Date	Wednesday, January 21, 2009 Sheet 47 of 51
	Rev 0A

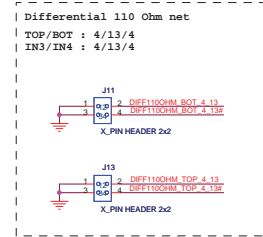
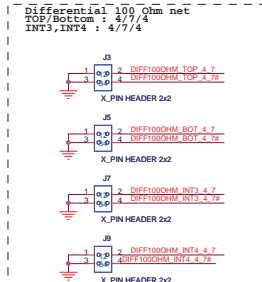
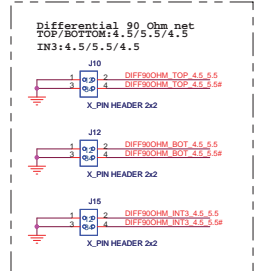
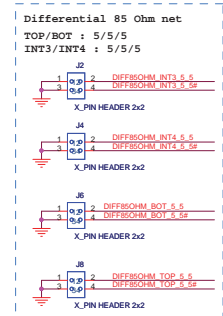
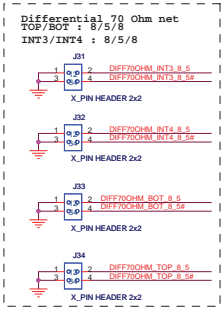
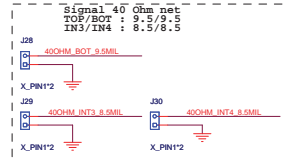
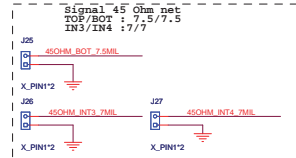
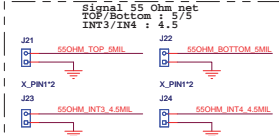
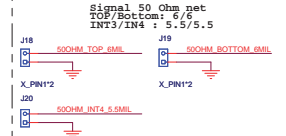
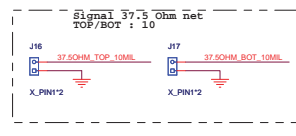

<http://laptop-motherboard-schematic.blogspot.com/>

 MICRO-STAR INT'L CO.,LTD.	
File: Constrain	
Size: Custom	Document Number: MS-1682
Date: Wednesday, January 21, 2009	Sheet: 48 of 51
	Rev: 0A

CARD_B_ BUTTOM

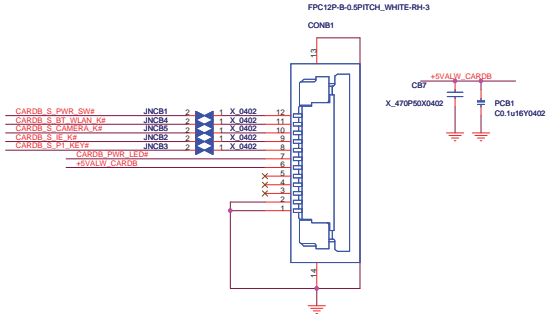
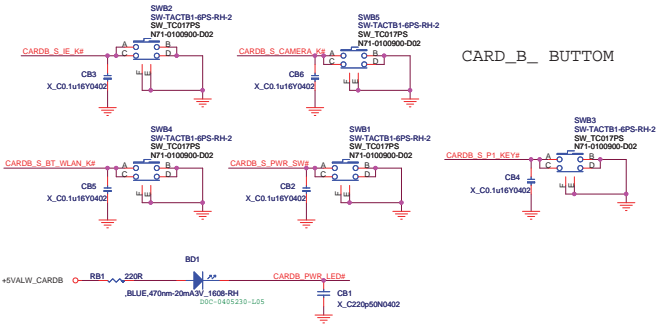

PCBA2
 P30-1682B0B-H73, 胜 痴缺(履集仁)
 P30-1682B0B-D05, 纒()纒 喇),

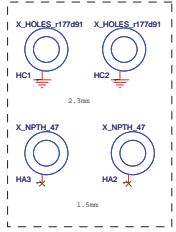

<http://laptop-motherboard-schematic.blogspot.com/>

		MICRO-STAR INT'L CO.,LTD.	
File		B10/M0	
Title		Button Board	
Size	Document Number		
Customer	MS-16821B		Rev 0A
Date	Wednesday, January 21, 2009	Sheet	49 of 51

0A -- 0B Note

MS-1682

P03, C579 INSTALL by SA BUG ,R41 CHANGE F/P TO R0603
P04, C639,C623,C612,C640,C624 INSTALL X5R
P06, R322 INSTALL
P07, R177,R171 CHANGE 36R , R170,R176 CHANGE 40.2R ,JNC70,JNC75 CHANGE F/P TO NC_0603
P14, R124,R125,R301 CHANG JNC81,JNC82,JNC83 AND INSTALL , R67,R68 DEL ,ADD PR135,RN28,JNC80,R346 ,R346 CHANGE F/P TO R0603, U5 PIN 8 ,7 CHANGE NET NAME ,JNC29 &R85 CHANGE
P15, C50 INSTALL
P16, R52,R246 INSTALL ,R51,R242 DON'T INSTALL
P18, R225,R227,R13,R14 CHANGE 499R
P19, R223,R224,R12,R11 CHANGE 499R
P20, CHANGE U15 FOOTPRINT TO " SOT23_5_NPC30X " , VGA_DATA AND VGA_CLK AND *J38 : PIN 30 "CHANGE TO +3.3V_DELAY , R232,R233 ,C486,C487,C488 INSTALL
P21, RN14 PIN 2,4 SWAP PIN 6,8
P22, DEL SPI_SKET1,JNC66,JNC67,JNC71,JNC72,CON4 , R318 INSTALL, R317 DON'T INSTALL ,JNC34 ,JNC33 CHANGE F/P TO NC_0603
P23, JNC65,JNC64,JNC59,JNC56,JNC55 INSTALL by SA BUG ,R41 CHANGE F/P TO R0603
P26, CN5 CHANGE CAD, CN6 CHANGE LAYOUT AND PIN 6 TO GND
P27, DEL D1,D2, R212 CHANGE TO +5VSUS
P28, R189 CHANGE 0 Ohm AND INSTALL , CHANGE CON5 PIN 29,20,27 NET NAME, DEL R187,R186 , U12 CHANGE 5159 "B07-0515904-R09 "
P29, Y1 CHANGE F/P, U23 NET CHANGE
P30, JGFS1 DON'T INSTALL, USIM_PWR > 25 mils, DEL SW1,SW2,SW3,SW4,JNC1,2,3,4
P31, R112,D16 TO ALLSYSPG, R115,C212 NOT INSTALL, R108 INSTALL
P32, R290 CHANGE TO 33K ,C622 CHANGE TO 4.7U,CON7 SWAP PIN 1 &PIN 2
P33, U20 CHANGE FOOTPRINT SIC8_SST_S2A , CN3 CHANGE NEW PN , DEL R346 TO RUN_PG, U3 PIN 113 CHANGE TO PIN 23 , U3 PIN 98 & PIN 130 SWAP,JNC8 CGANGE R38 , ADD R354 220HM , SW5,SW6 SWAP LAYOUT, YT1 MOVE
P34, JNC19 CHANGE R345 DON'T INSTALL ,J37 CHANGE FOOT PRINT
P36, PR12 360 CHANGE 620 (R11-0621T12-R01) (pre-charge current), PR16 9.31K CHANGE 28.7K(R11-2872T12-W08) (6-CELL charge current)
P37, PR107 CHANGE 10K ,INSTALL PC103
P38, ADD PQ36 TO DELAY +1.8VRUN, DEL PR135,PC159 , DON'T INSTALL PR114
P39, PU4 PIN4 TO ALLSYSPG ,PR77 CHANGE 0 Ohm, PC69 DON'T INSTALL ,PC72 10uF CHANGE 4.7uF(C11-4753014-W08) (jitter)
P40, PR4 CHANGE TO 10K Ohm ,PR63 147 CHANGE 147K(R11-1473T12-Y01) ,ADD GPU_PHERGD NET WAY
P41, PR63 CHANGE TO 147K Ohm , ADD R353 DON'T INSTALL ,C613 INSTALL
P42 , H1:P30 ,MH1:CHANGE TO 5020
P47 , CONA1 CHANGE LAYOUT

JNC21, JNC80 5A
ADD PR144 TO +5VRUN -#check
ADD PR145 TO +3VRUN -#check

<http://laptop-motherboard-schematic.blogspot.com/>

MSI CORPORATION		
Title	Note	
Size	Document Number	Rev
Custom	MS-1682	0A
Date	Wednesday, January 21, 2009	Sheet 60 of 61

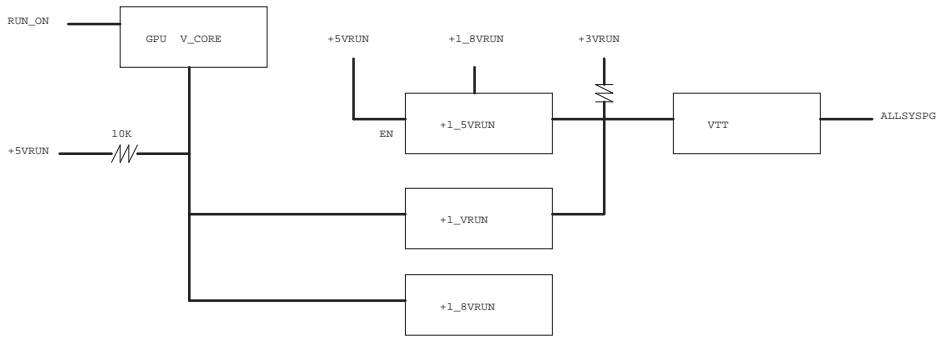

<http://laptop-motherboard-schematic.blogspot.com/>

MSI CORPORATION		
File Note		
Size	Document Number	Rev
Custom	MS-1682	0A
Date	Wednesday, January 21, 2009	Sheet 01 of 01