 **MS-7211 Ver:0A**

**CPU:**

Intel Prescott LGA775 -Mainstream CPU

**System Chipset:**

North Bridge : VIA P4M800 Ver:CE  
 South Bridge : VIA VT8237R Plus

**On Board Chipset:**

LPC Super I/O -- W83627EHF  
 LAN --- RTL 8100C (10/100) / 8110SB (Giga)  
 AC'97 Codec --Realtek ALC655  
 BIOS --LPC FLASH ROM

**CLOCK Chip :**

CLOCK Generator -- Realtek RTM862-520  
 / ICS ICS950917AF

**Main Memory:**

DDR \* 2 (Max 2GB)

**Expansion Slots:**

PCI 2.3 SLOT \* 2

**PWM:**

VRM10.1 Intersil 6566 3Phase

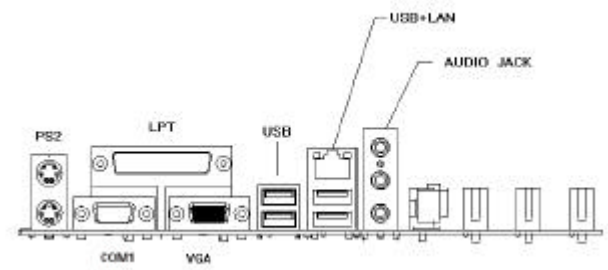

**CHIPSET P4M800 CE + VT8237 PLUS**

TITLE	SHEET
COVER SHEET	1
BLOCK DIAGRAM	2
PWR And CLOCK Map	3
GPIO/MEMORY/PCI/HW STRPPING	4
PROCESSOR ( Intel LGA775)	5, 6, 7
NORTH BRIDGE P4M800_CE	8, 9, 10, 11
DIMM1&2	12
DIMM1&2 Terminations	13
AGP SLOT	14
VGA Connector	15
Clock Generator RTM862-520 / ICS950917AF	16
SOUTH BRIDGE (VT8237R Plus)	17, 18, 19
PCI Slot 1 & 2	20
Realtek 8100C/8110SB	21
Super I/O & FAN 83627EHF-D	22
AC97 Realtek ALC655	23
IDE Connectors , KB/MS	24
USB Connectors	25
COM / Parallel Port	26
MS7 ACPI Controller	27
VRM 10.1 - Intersil 6566_3 Phases	28
ATX & F_Panel & BIOS	29
PCB Components & EMI	30

# Block Diagram

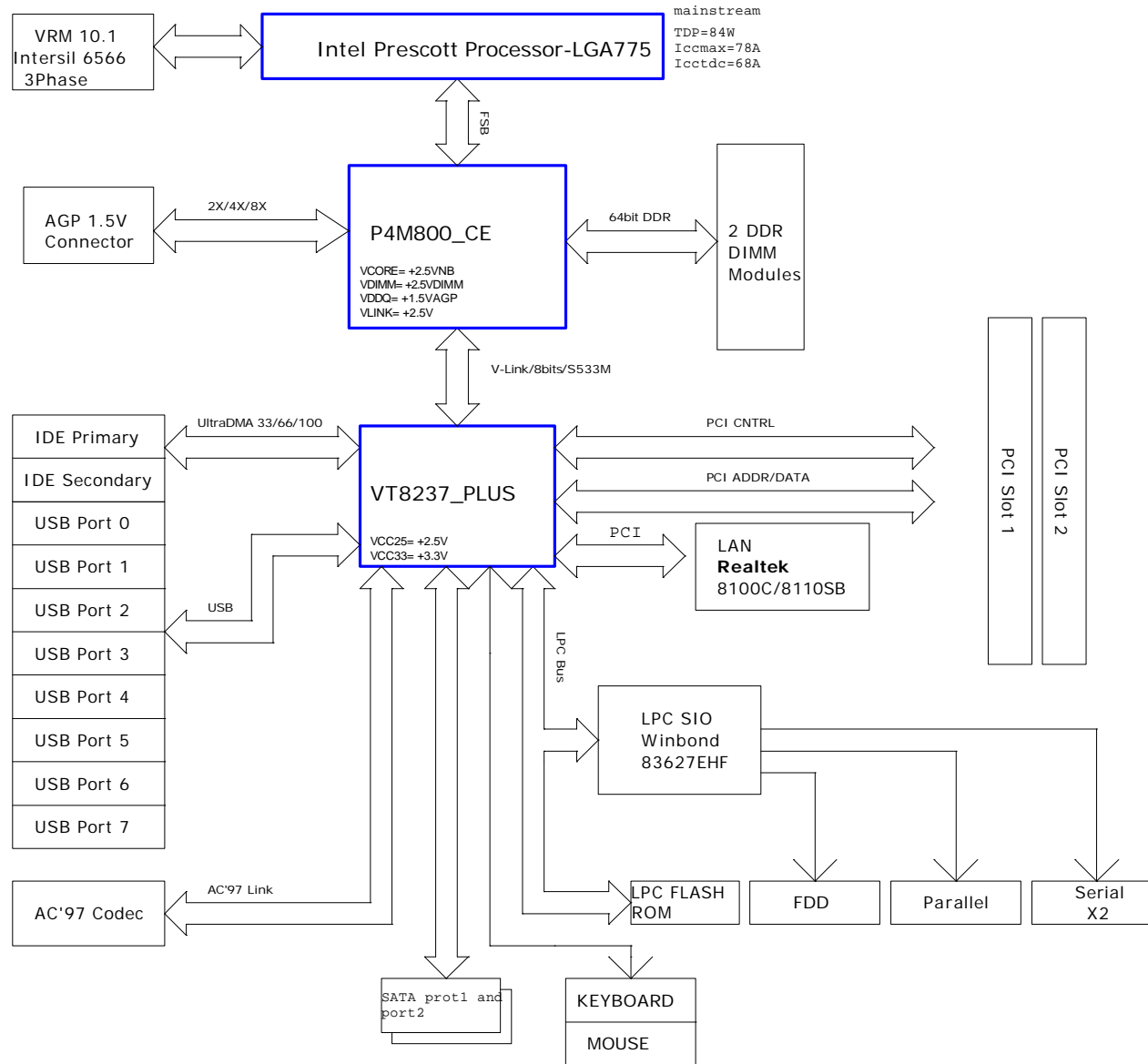

### P4M800 PLATFORM CLOCK GENERATOR MAP

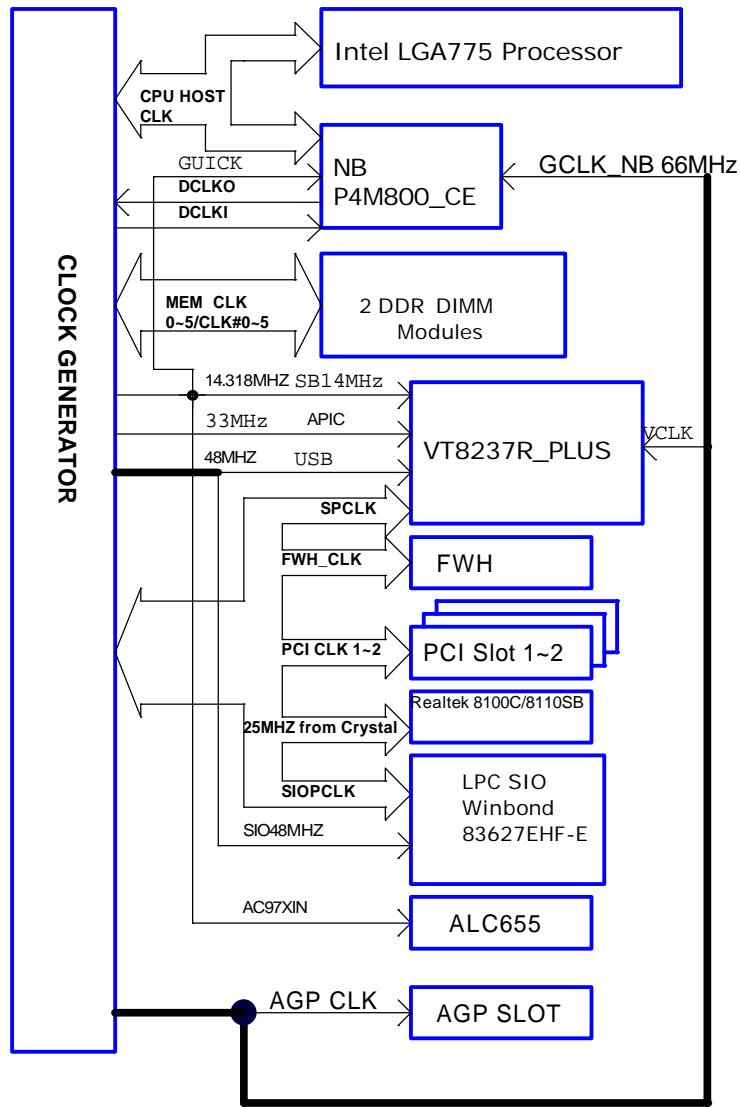

### P4M800\_CE PLATFORM POWER DELIVERY MAP

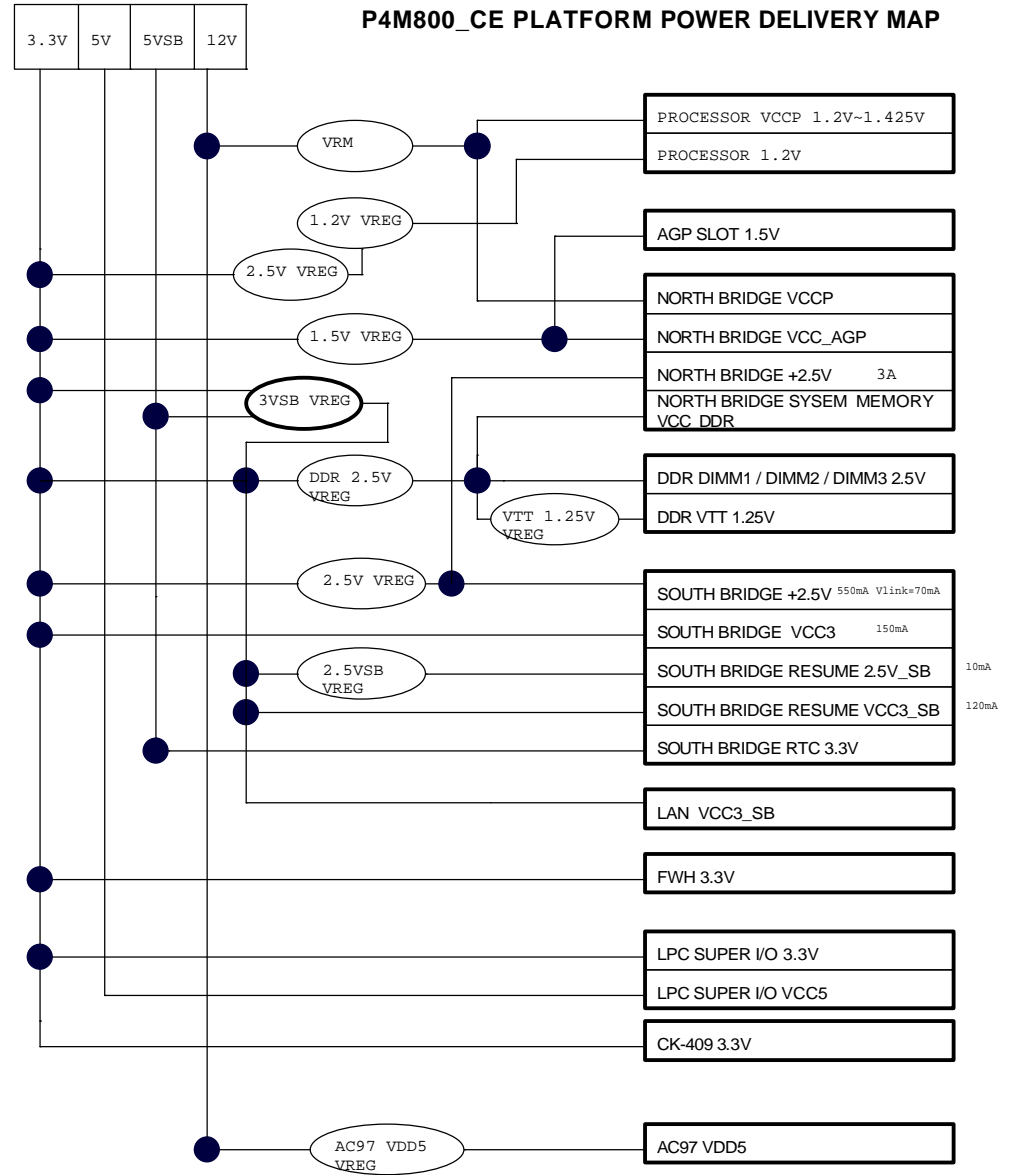

+12V : 0.1U 25V X 5  
 +12V\_MOS: 4.7U 35V X 1  
 1U 16V X 2  
 1000U 16V X 4

## VT8237R\_PLUS GPIO Function Define

PIN NAME	Default Function	Function define
GPO0 (VDDS)	GPO0	4.7K ohm Pull up to VCC3_SB
GPO1 (VDDS)	GPO1	4.7K ohm Pull up to VCC3_SB
GPO2/SUSA# (VDDS)	SUSA#	4.7K ohm Pull up to VCC3_SB
GPO3/SUSST# (VDDS)	SUSST#	4.7K ohm Pull up to VCC3_SB
GPO4/SUSCLK (VDDS)	SUSCLK	4.7K ohm Pull up to VCC3_SB
GPO5/CPUSTP#	CPUSTP#	4.7K ohm Pull up to VCC3
GPO6/PCISTP#	PCISTP#	4.7K ohm Pull up to VCC3
GPO7/GNT5	GPO7	8.2K ohm Pull up to VCC3
* GPO8/GPI8/VGATE	GPI8	4.7K ohm Pull up to VCC3
* GPO9/GPI9/UDPWREN	UDPWREN	NC
* GPO10/GPI10/PICD0	GPI10	1K ohm Pull up to VCC3
* GPO11/GPI11/PICD1	GPI11	1K ohm Pull up to VCC3
* GPO12/GPI12/INTE#	GPI12	8.2K ohm Pull up to VCC3
* GPO13/GPI13/INTF#	GPI13	8.2K ohm Pull up to VCC3
* GPO14/GPI14/INTG#	GPI14	8.2K ohm Pull up to VCC3
* GPO15/GPI15/INTH#	GPI15	8.2K ohm Pull up to VCC3
GPO20/GPI20/ACSDIN2/PCS0#	GPI20/ACSDIN2	4.7K ohm Pull down
GPO21/GPI21/ACSDIN3/PCS1#/SLPBTN#	GPI21/ACSDIN3	4.7K ohm Pull down
GPO22/GPI22/GHI#	GPI22	4.7K ohm Pull up to VCC3
GPO23/GPI23/DPSTP	GPI23	4.7K ohm Pull up to VCC3
GPO24/GPI24 /GPIOA	GPI24	BSEL1
GPO25/GPI25 /GPIOB	GPI25	4.7K ohm Pull down
GPO26/GPI26/SMBDT2 (VDDS)	SMBDT2	2.7K ohm Pull up to VCC3_SB
GPO27/GPI27/SMBCK2 (VDDS)	SMBCK2	2.7K ohm Pull up to VCC3_SB
GPO28/GPI28/VIDSEL	GPO28 /VIDSEL	SATA_LED
GPO29/GPI29/VRDSTP	GPO29 /VRDSTP	4.7K ohm Pull down
GPO30/GPI30 /GPIOC	GPI30	BSEL0
GPO31/GPI31 /GPIOD	GPI31	4.7K ohm Pull down

PIN NAME	Default Function	Function define
GPI0 (VBAT)	GPI0	1M ohm Pull up to VBAT
GPI1 (VSUS3)	GPI1	ATADET0=>Detect IDE1 ATA100/66
GPI2/EXTSMI# (VSUS3)	EXTSMI#	4.7K ohm Pull up to VCC3_SB
GPI3/RING# (VSUS3)	RING#	RING# 4.7K ohm Pull up to VCC3_SB
GPI4/LID# (VSUS3)	LID#	ATADET1=>Detect IDE2 ATA100/66
GPI5/BATLOW# (VDDS)	BATLOW#	4.7K ohm Pull up to VCC3_SB
GPI6/AGPBZ	AGPBZ	4.7K ohm Pull up to VCC3
GPI7/REQ5	GPI7	8.2K ohm Pull up to VCC3
* GPI8/VGATE	GPI8	4.7K ohm Pull up to VCC3
* GPI9/UDPWREN	UDPWREN	NC
* GPI10/PICD0	GPI10	1K ohm Pull up to VCC3
* GPI11/PICD1	GPI11	1K ohm Pull up to VCC3
* GPI12/INTE#	GPI12	8.2K ohm Pull up to VCC3
* GPI13/INTF#	GPI13	8.2K ohm Pull up to VCC3
* GPI14/INTG#	GPI14	8.2K ohm Pull up to VCC3
* GPI15/INTH#	GPI15	8.2K ohm Pull up to VCC3
GPI16/INTRUDER# (VBAT)	INTRUDER#	1M ohm Pull up to VBAT
GPI17/CPUMISS	CPUMISS	4.7K ohm Pull up to VCC3_SB
GPI18/AOLGP1/THRM#	AOLGP1	4.7K ohm Pull up to VCC3_SB
GPI19/APICCLK	APICCLK	APICCLK

### PCI Config.

DEVICE	MCP1 INT Pin	REQ#/GNT#	IDSEL	CLOCK	CLK GEN PIN OUT
PCI Slot 1	PIRQ#B PIRQ#C PIRQ#D PIRQ#A	PCIREQ#1 PCIGNT#1	AD19	PCI_CLK1	14
PCI Slot 2	PIRQ#C PIRQ#D PIRQ#A PIRQ#B	PCIREQ#2 PCIGNT#2	AD20	PCI_CLK2	15
LAN 8110SB	PIRQ#E	PCIREQ#0 PCIGNT#0	AD17	LAN_CLK	11

USB	Port	DATA +/-	OC#
Rear	I1394_USB1	USB1- USB1+ USB0- USB0+	OC#1 ( OC#0~3 )
	LAN_USB1	USB2- USB2+ USB3- USB3+	
Front	JUSB1	USB4- USB4+ USB6- USB6+	OC#4 ( OC#4~7 )
	JUSB2	USB5- USB5+ USB7- USB7+	

### PCI RESET DEVICE

Signals	Target
PCIRST#1	PCI slot 1-2
PCIRST#2	NB , Super I/O , LPC, LAN
HD_RST#	Primary, Scondary IDE

### DDR DIMM Config.

DEVICE	ADDRESS	CLOCK
DIMM 1	1010000B	DCLKA0/MDCLKA#0 DCLKA1/MDCLKA#1 DCLKA2/MDCLKA#2
DIMM 2	1010001B	DCLKA3/MDCLKA#3 DCLKA4/MDCLKA#4 DCLKA5/MDCLKA#5

# CPU SIGNAL BLOCK

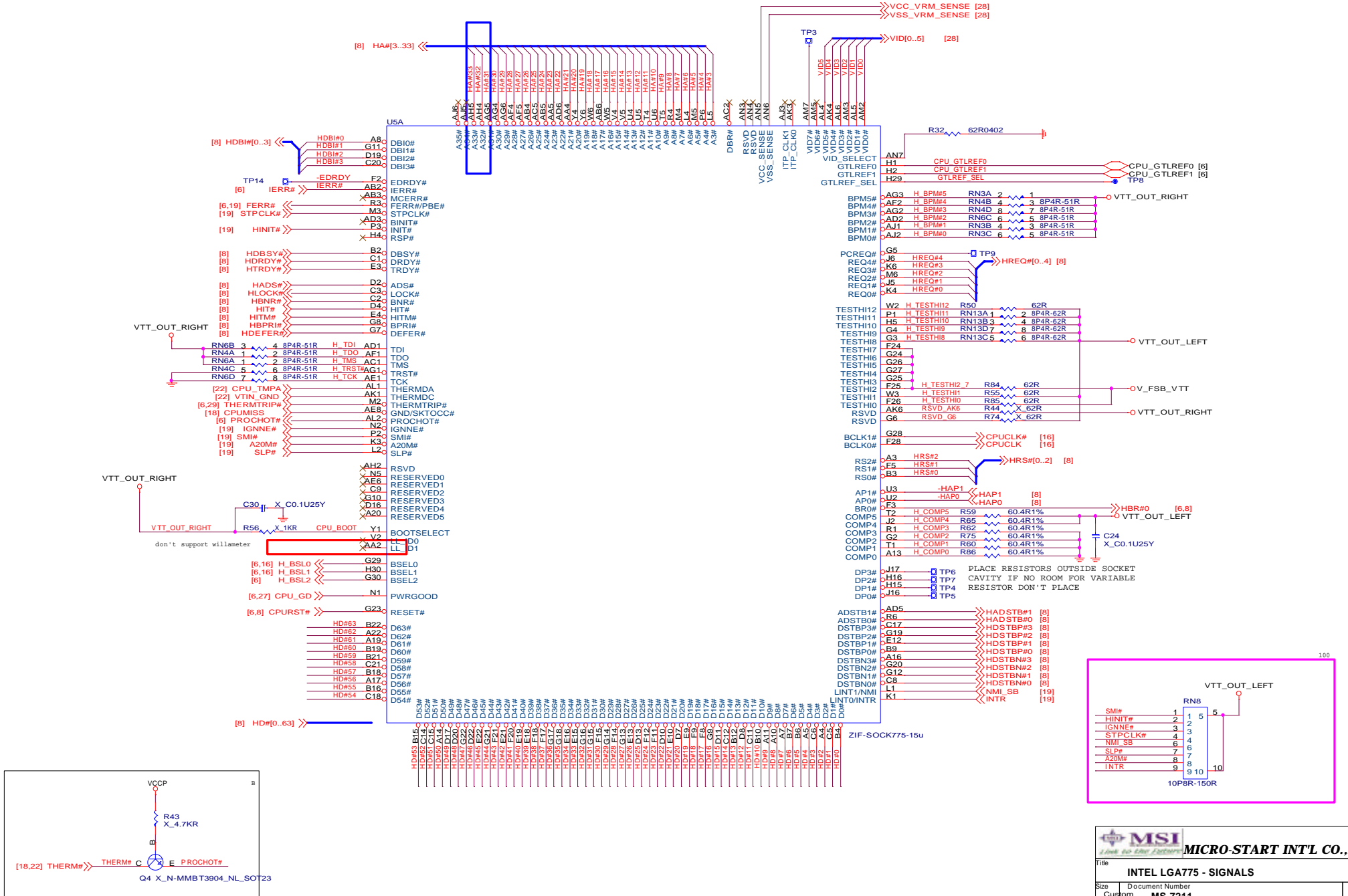

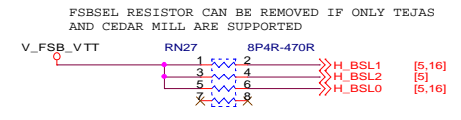
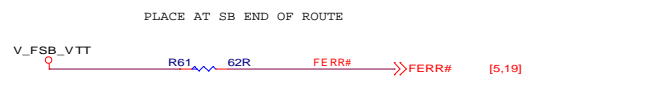
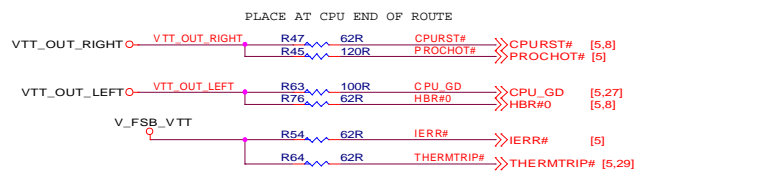
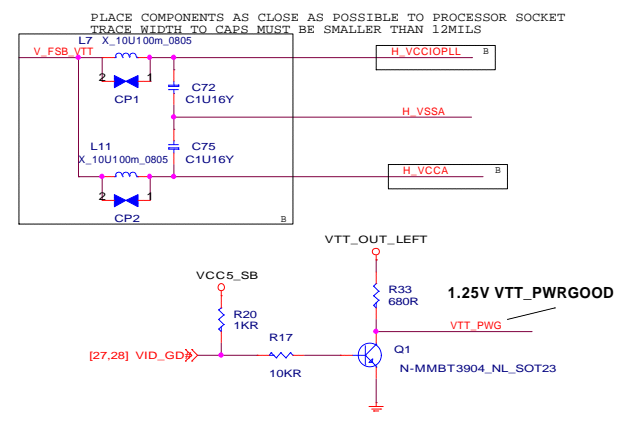
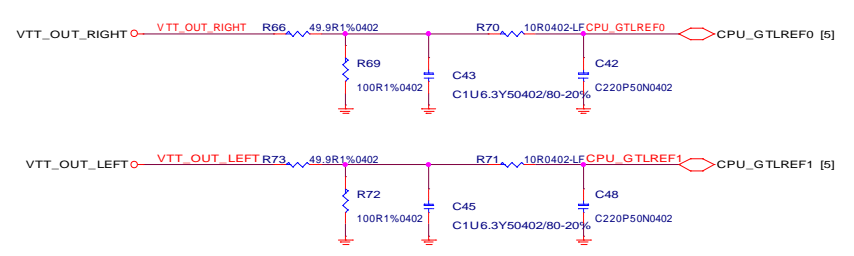
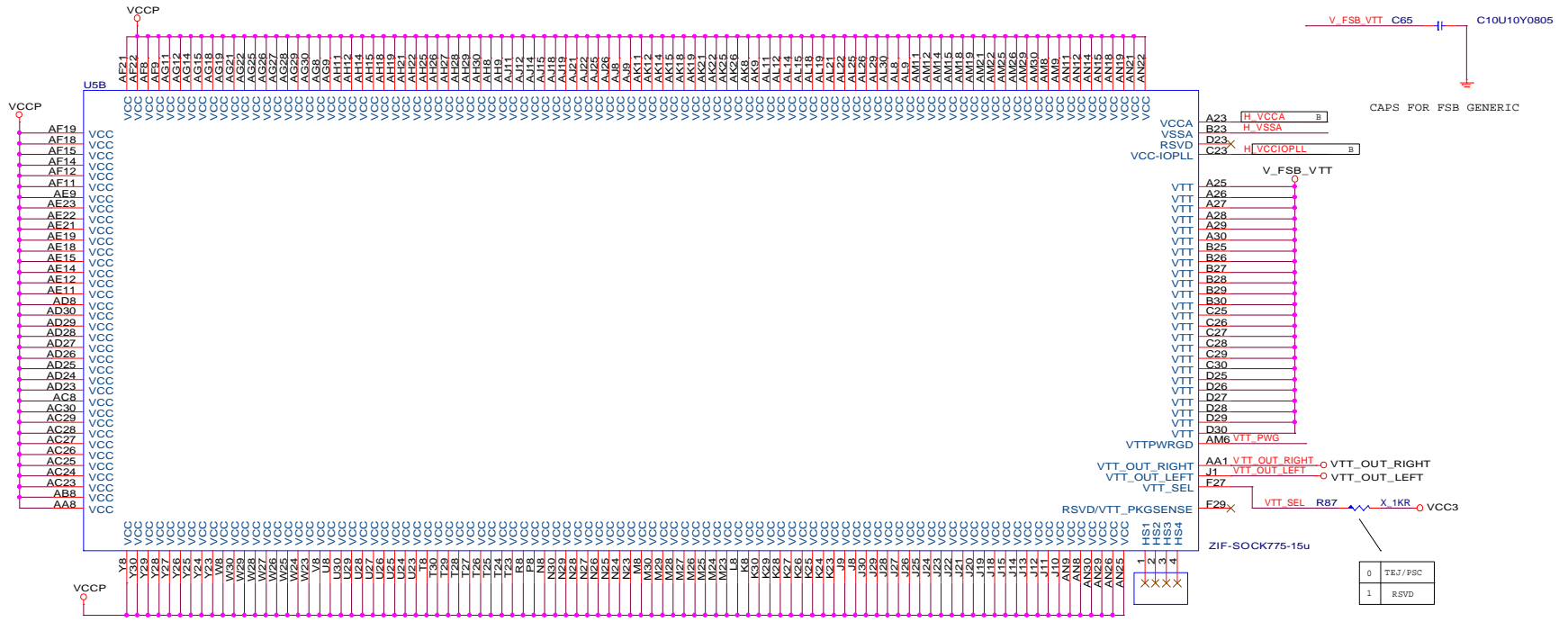

VTT\_OUT\_RIGHT

VTT\_OUT RIGHT

GTLVREF\_NB

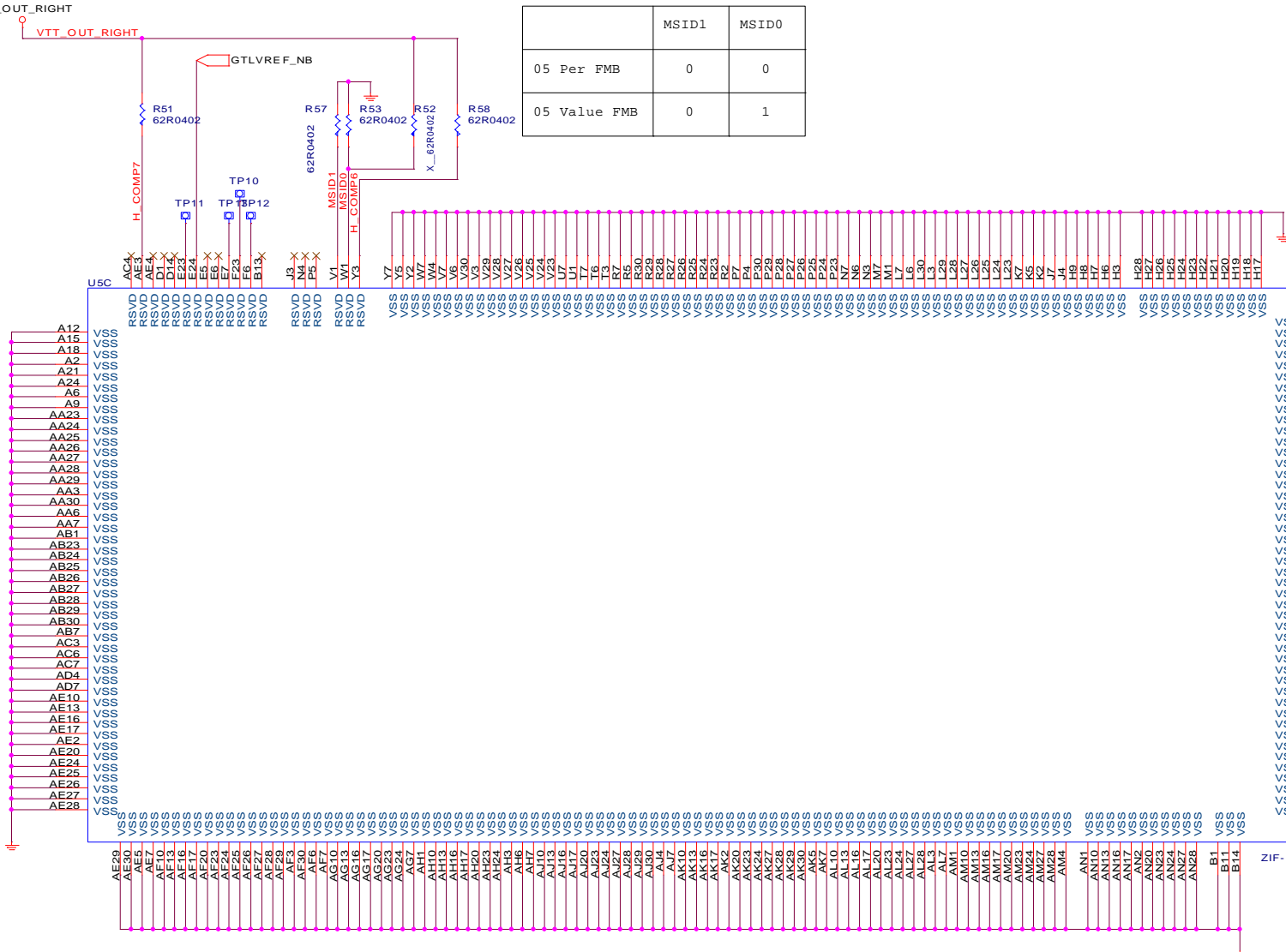

	MSID1	MSID0
05 Per FMB	0	0
05 Value FMB	0	1

- |      |     |      |           |         |     |     |     |     |
|------|-----|------|-----------|---------|-----|-----|-----|-----|
| A12  | VSS | AC4  | R51       | 62R0402 | Y7  | VSS | H14 | VSS |
| A15  | VSS | AE4  | R57       | 62R0402 | Y2  | VSS | H13 | VSS |
| A18  | VSS | D11  | R53       | 62R0402 | Y4  | VSS | H12 | VSS |
| A2   | VSS | E23  | R58       | 62R0402 | Y6  | VSS | H11 | VSS |
| A21  | VSS | E24  | X_62R0402 | V30     | VSS | H10 | VSS |     |
| A24  | VSS | E5   |           | V28     | VSS | G1  | VSS |     |
| A6   | VSS | E6   |           | V27     | VSS | F7  | VSS |     |
| A9   | VSS | E9   |           | V26     | VSS | F4  | VSS |     |
| AA23 | VSS | F2   |           | V24     | VSS | F22 | VSS |     |
| AA24 | VSS | F3   |           | V23     | VSS | F19 | VSS |     |
| AA25 | VSS | F4   |           | V22     | VSS | F16 | VSS |     |
| AA26 | VSS | F5   |           | V21     | VSS | F13 | VSS |     |
| AA27 | VSS | F6   |           | V20     | VSS | F10 | VSS |     |
| AA28 | VSS | F7   |           | V19     | VSS | E8  | VSS |     |
| AA29 | VSS | F8   |           | V18     | VSS | E29 | VSS |     |
| AA3  | VSS | F9   |           | V17     | VSS | E28 | VSS |     |
| AA30 | VSS | F10  |           | V16     | VSS | E27 | VSS |     |
| AA6  | VSS | F11  |           | V15     | VSS | E26 | VSS |     |
| AA7  | VSS | F12  |           | V14     | VSS | E25 | VSS |     |
| AB1  | VSS | F13  |           | V13     | VSS | E20 | VSS |     |
| AB23 | VSS | F14  |           | V12     | VSS | E2  | VSS |     |
| AB24 | VSS | F15  |           | V11     | VSS | E17 | VSS |     |
| AB25 | VSS | F16  |           | V10     | VSS | E14 | VSS |     |
| AB26 | VSS | F17  |           | V9      | VSS | E11 | VSS |     |
| AB27 | VSS | F18  |           | V8      | VSS | D9  | VSS |     |
| AB28 | VSS | F19  |           | V7      | VSS | D6  | VSS |     |
| AB29 | VSS | F20  |           | V6      | VSS | D5  | VSS |     |
| AB30 | VSS | F21  |           | V5      | VSS | D3  | VSS |     |
| AB7  | VSS | F22  |           | V4      | VSS | D24 | VSS |     |
| AC3  | VSS | F23  |           | V3      | VSS | D21 | VSS |     |
| AC6  | VSS | F24  |           | V2      | VSS | D18 | VSS |     |
| AG7  | VSS | F25  |           | V1      | VSS | D15 | VSS |     |
| AD4  | VSS | F26  |           | V0      | VSS | D12 | VSS |     |
| AD7  | VSS | F27  |           | V0      | VSS | C7  | VSS |     |
| AE10 | VSS | F28  |           | V0      | VSS | C4  | VSS |     |
| AE13 | VSS | F29  |           | V0      | VSS | C24 | VSS |     |
| AE16 | VSS | F30  |           | V0      | VSS | C22 | VSS |     |
| AE17 | VSS | F31  |           | V0      | VSS | C19 | VSS |     |
| AE2  | VSS | F32  |           | V0      | VSS | C16 | VSS |     |
| AE20 | VSS | F33  |           | V0      | VSS | C13 | VSS |     |
| AE24 | VSS | F34  |           | V0      | VSS | C10 | VSS |     |
| AE25 | VSS | F35  |           | V0      | VSS | B8  | VSS |     |
| AE26 | VSS | F36  |           | V0      | VSS | B5  | VSS |     |
| AE27 | VSS | F37  |           | V0      | VSS | B24 | VSS |     |
| AE28 | VSS | F38  |           | V0      | VSS | B20 | VSS |     |
| AE29 | VSS | F39  |           | V0      | VSS | B17 | VSS |     |
| AE30 | VSS | F40  |           | V0      | VSS |     |     |     |
| AE5  | VSS | F41  |           | V0      | VSS |     |     |     |
| AE7  | VSS | F42  |           | V0      | VSS |     |     |     |
| AE10 | VSS | F43  |           | V0      | VSS |     |     |     |
| AE16 | VSS | F44  |           | V0      | VSS |     |     |     |
| AE17 | VSS | F45  |           | V0      | VSS |     |     |     |
| AE20 | VSS | F46  |           | V0      | VSS |     |     |     |
| AE24 | VSS | F47  |           | V0      | VSS |     |     |     |
| AE25 | VSS | F48  |           | V0      | VSS |     |     |     |
| AE26 | VSS | F49  |           | V0      | VSS |     |     |     |
| AE27 | VSS | F50  |           | V0      | VSS |     |     |     |
| AE28 | VSS | F51  |           | V0      | VSS |     |     |     |
| AE3  | VSS | F52  |           | V0      | VSS |     |     |     |
| AF30 | VSS | F53  |           | V0      | VSS |     |     |     |
| AF6  | VSS | F54  |           | V0      | VSS |     |     |     |
| AG10 | VSS | F55  |           | V0      | VSS |     |     |     |
| AG13 | VSS | F56  |           | V0      | VSS |     |     |     |
| AG16 | VSS | F57  |           | V0      | VSS |     |     |     |
| AG17 | VSS | F58  |           | V0      | VSS |     |     |     |
| AG23 | VSS | F59  |           | V0      | VSS |     |     |     |
| AG24 | VSS | F60  |           | V0      | VSS |     |     |     |
| AG7  | VSS | F61  |           | V0      | VSS |     |     |     |
| AH10 | VSS | F62  |           | V0      | VSS |     |     |     |
| AH13 | VSS | F63  |           | V0      | VSS |     |     |     |
| AH16 | VSS | F64  |           | V0      | VSS |     |     |     |
| AH17 | VSS | F65  |           | V0      | VSS |     |     |     |
| AH23 | VSS | F66  |           | V0      | VSS |     |     |     |
| AH24 | VSS | F67  |           | V0      | VSS |     |     |     |
| AH3  | VSS | F68  |           | V0      | VSS |     |     |     |
| AH6  | VSS | F69  |           | V0      | VSS |     |     |     |
| AH10 | VSS | F70  |           | V0      | VSS |     |     |     |
| AH13 | VSS | F71  |           | V0      | VSS |     |     |     |
| AJ16 | VSS | F72  |           | V0      | VSS |     |     |     |
| AJ17 | VSS | F73  |           | V0      | VSS |     |     |     |
| AJ23 | VSS | F74  |           | V0      | VSS |     |     |     |
| AJ24 | VSS | F75  |           | V0      | VSS |     |     |     |
| AJ27 | VSS | F76  |           | V0      | VSS |     |     |     |
| AJ28 | VSS | F77  |           | V0      | VSS |     |     |     |
| AJ30 | VSS | F78  |           | V0      | VSS |     |     |     |
| AJ4  | VSS | F79  |           | V0      | VSS |     |     |     |
| AJ7  | VSS | F80  |           | V0      | VSS |     |     |     |
| AK13 | VSS | F81  |           | V0      | VSS |     |     |     |
| AK16 | VSS | F82  |           | V0      | VSS |     |     |     |
| AK17 | VSS | F83  |           | V0      | VSS |     |     |     |
| AK2  | VSS | F84  |           | V0      | VSS |     |     |     |
| AK23 | VSS | F85  |           | V0      | VSS |     |     |     |
| AK24 | VSS | F86  |           | V0      | VSS |     |     |     |
| AK27 | VSS | F87  |           | V0      | VSS |     |     |     |
| AK28 | VSS | F88  |           | V0      | VSS |     |     |     |
| AK30 | VSS | F89  |           | V0      | VSS |     |     |     |
| AK5  | VSS | F90  |           | V0      | VSS |     |     |     |
| AK7  | VSS | F91  |           | V0      | VSS |     |     |     |
| AL10 | VSS | F92  |           | V0      | VSS |     |     |     |
| AL16 | VSS | F93  |           | V0      | VSS |     |     |     |
| AL17 | VSS | F94  |           | V0      | VSS |     |     |     |
| AL20 | VSS | F95  |           | V0      | VSS |     |     |     |
| AL24 | VSS | F96  |           | V0      | VSS |     |     |     |
| AL27 | VSS | F97  |           | V0      | VSS |     |     |     |
| AL28 | VSS | F98  |           | V0      | VSS |     |     |     |
| AL3  | VSS | F99  |           | V0      | VSS |     |     |     |
| AM1  | VSS | F100 |           | V0      | VSS |     |     |     |
| AM10 | VSS | F101 |           | V0      | VSS |     |     |     |
| AM13 | VSS | F102 |           | V0      | VSS |     |     |     |
| AM16 | VSS | F103 |           | V0      | VSS |     |     |     |
| AM17 | VSS | F104 |           | V0      | VSS |     |     |     |
| AM2  | VSS | F105 |           | V0      | VSS |     |     |     |
| AM23 | VSS | F106 |           | V0      | VSS |     |     |     |
| AM24 | VSS | F107 |           | V0      | VSS |     |     |     |
| AM26 | VSS | F108 |           | V0      | VSS |     |     |     |
| AM4  | VSS | F109 |           | V0      | VSS |     |     |     |
| AN1  | VSS | F110 |           | V0      | VSS |     |     |     |
| AN13 | VSS | F111 |           | V0      | VSS |     |     |     |
| AN16 | VSS | F112 |           | V0      | VSS |     |     |     |
| AN17 | VSS | F113 |           | V0      | VSS |     |     |     |
| AN2  | VSS | F114 |           | V0      | VSS |     |     |     |
| AN23 | VSS | F115 |           | V0      | VSS |     |     |     |
| AN24 | VSS | F116 |           | V0      | VSS |     |     |     |
| AN27 | VSS | F117 |           | V0      | VSS |     |     |     |
| AN28 | VSS | F118 |           | V0      | VSS |     |     |     |
| B1   | VSS | F119 |           | V0      | VSS |     |     |     |
| B11  | VSS | F120 |           | V0      | VSS |     |     |     |
| B14  | VSS | F121 |           | V0      | VSS |     |     |     |

ZIF-SOCK775-15u

**MSI**  
Link to the Future

**MICRO-START INTL CO.,LTD.**

Title: INTEL LGA775 - GND

Size: A3	Document Number: MS-7211	Rev: 0A
Date: Thursday, July 28, 2005	Sheet: 7 of 32	

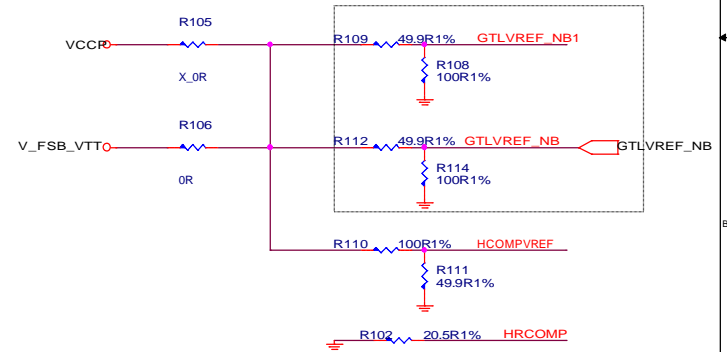
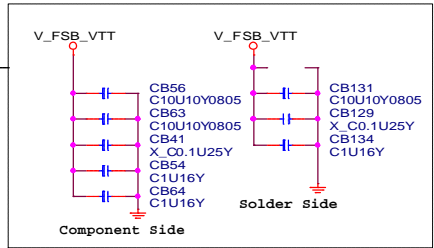
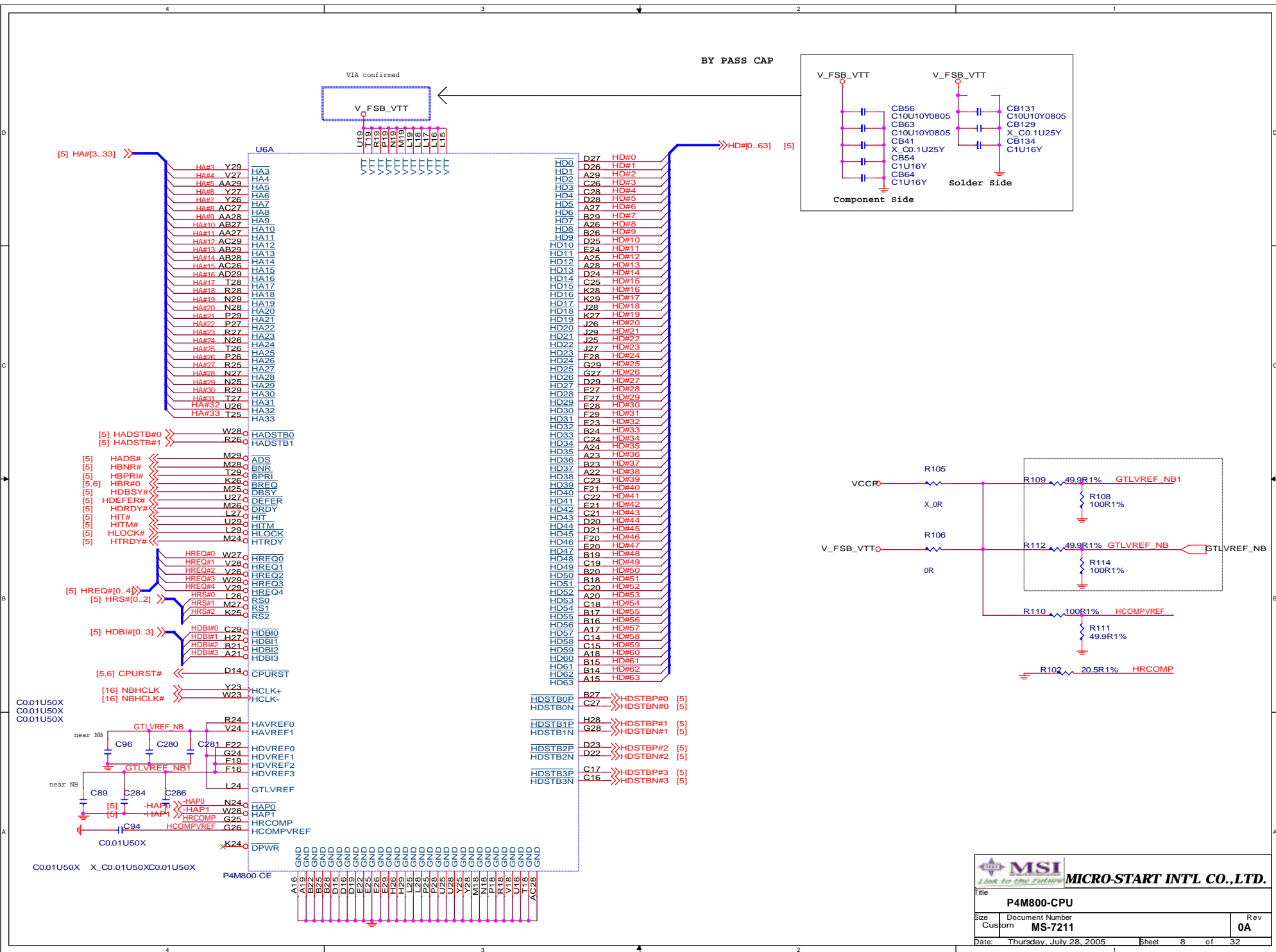

**MSI**  
 Link to the Future

**MICRO-START INT'L CO.,LTD.**

Title: **P4M800-CPU**

Size: Custom	Document Number: MS-7211	Rev: 0A
Date: Thursday, July 28, 2005		
Sheet 8 of 32		



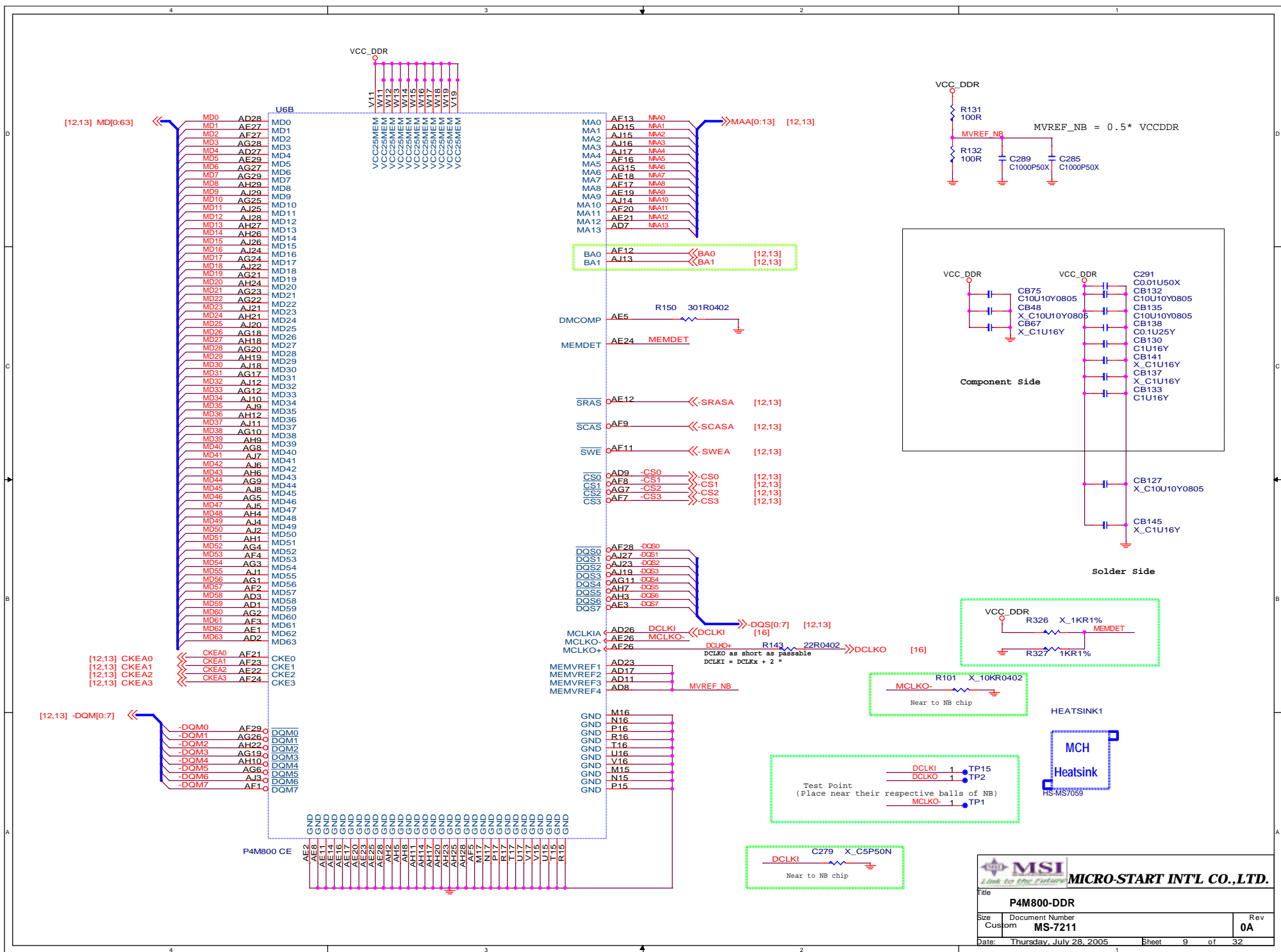



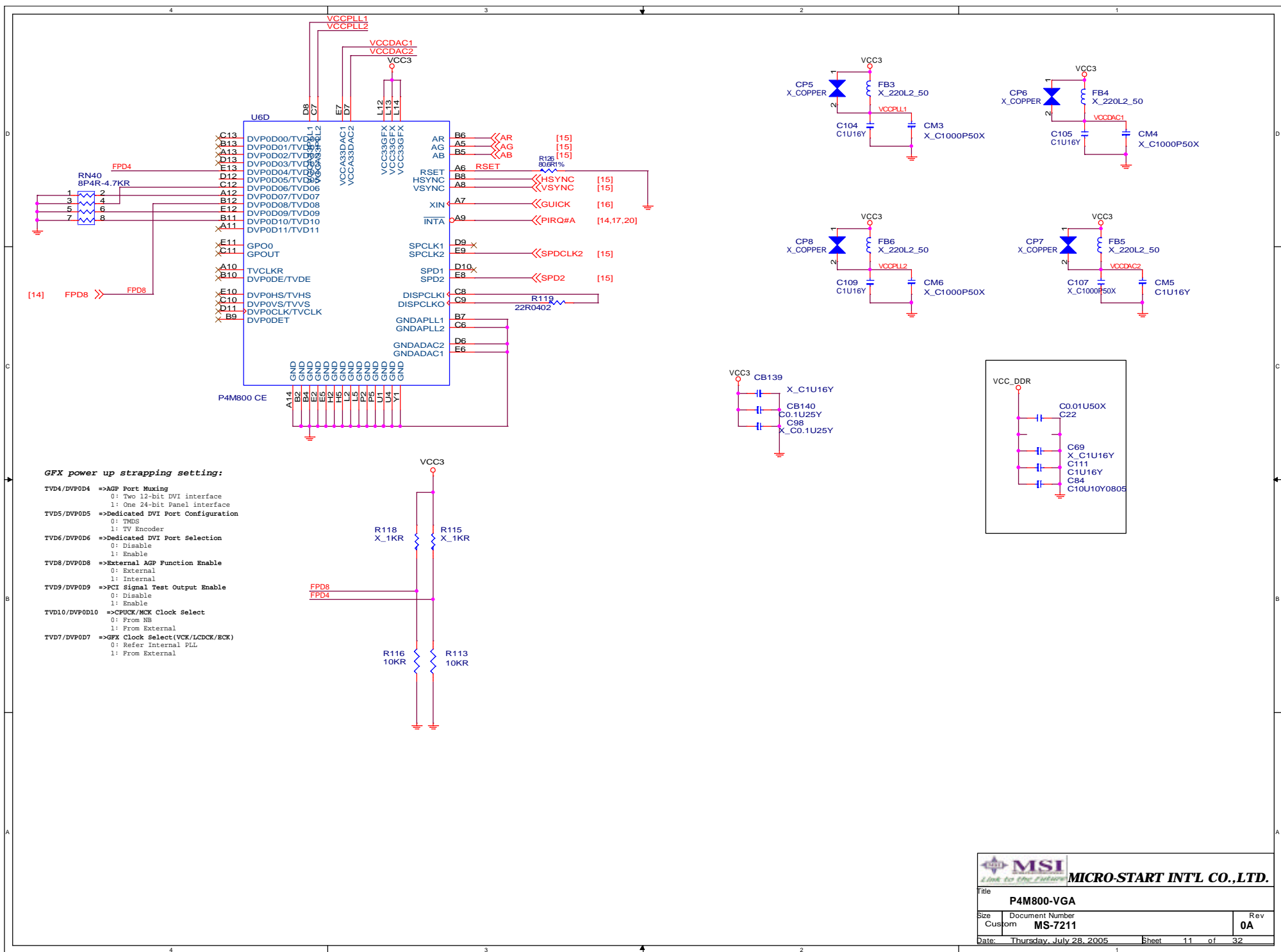

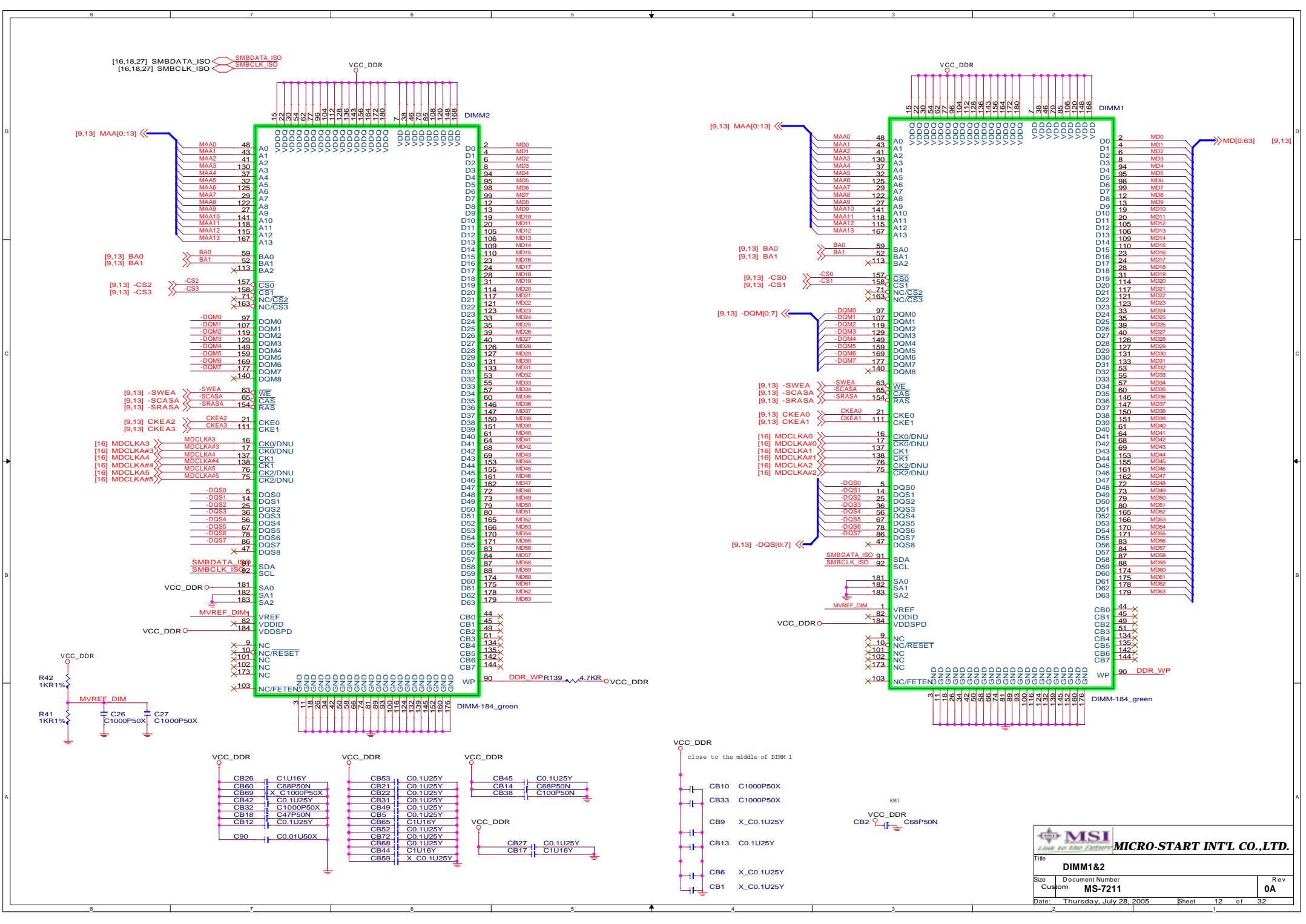



**MICRO-START INT'L CO.,LTD.**

Title: **DIMM1&2**  
 Size: Custom    Document Number: **MS-7211**    Rev: **0A**  
 Date: Thursday, July 28, 2005    Sheet: 12 of 32

# DIMM1 & 2 Terminations

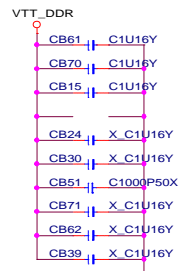
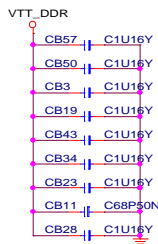
[9,12] MAA[0:13] << MAA[0:13]  
 [9,12] MD[0:63] << MD[0:63]  
 [9,12] -DQS[0:7] << -DQS[0:7]  
 [9,12] -DQM[0:7] << -DQM[0:7]

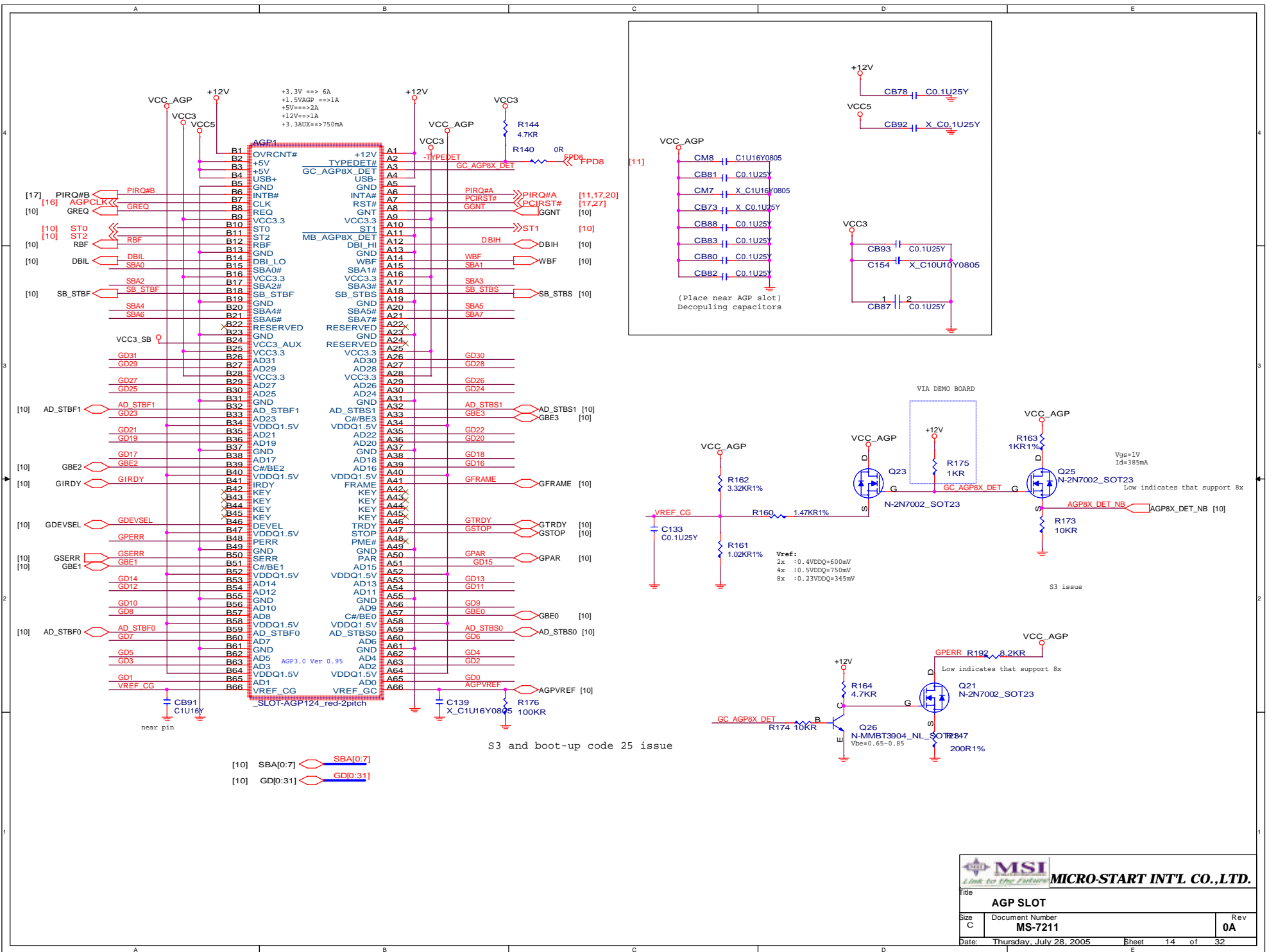



**MSI**  
Link to the Future

**MICRO-START INT'L CO., LTD.**

Title: **AGP SLOT**

Size C	Document Number <b>MS-7211</b>	Rev <b>0A</b>
Date: Thursday, July 28, 2005	Sheet 14 of 32	

# VGA CONNECTOR

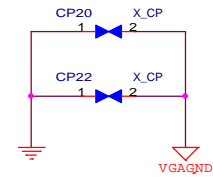
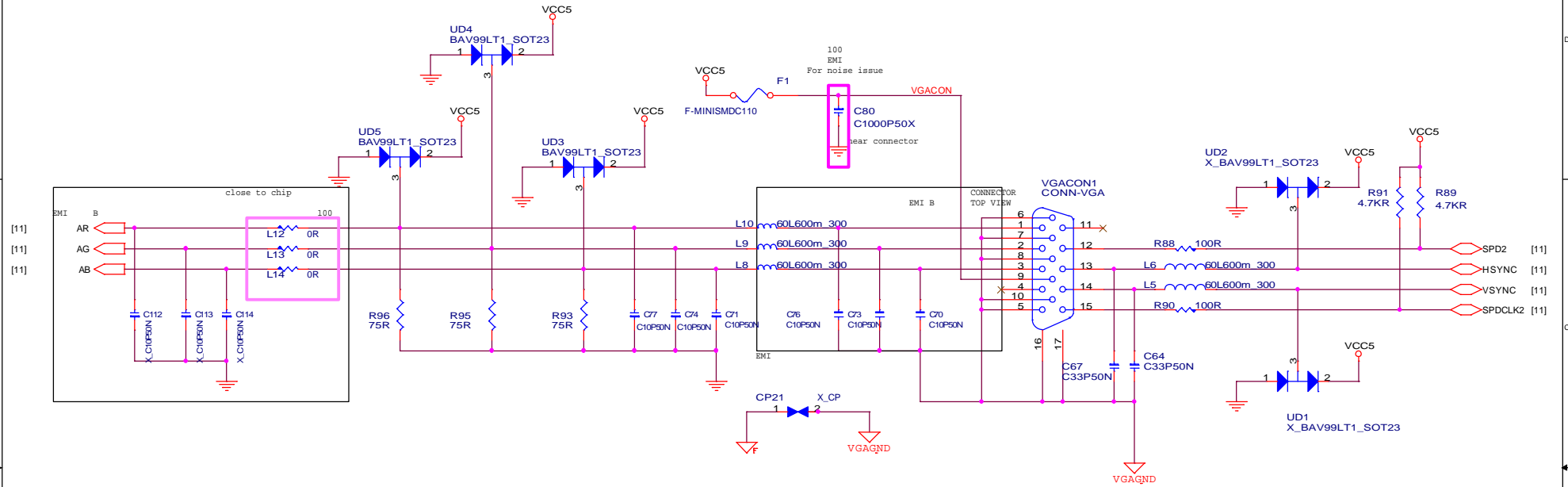

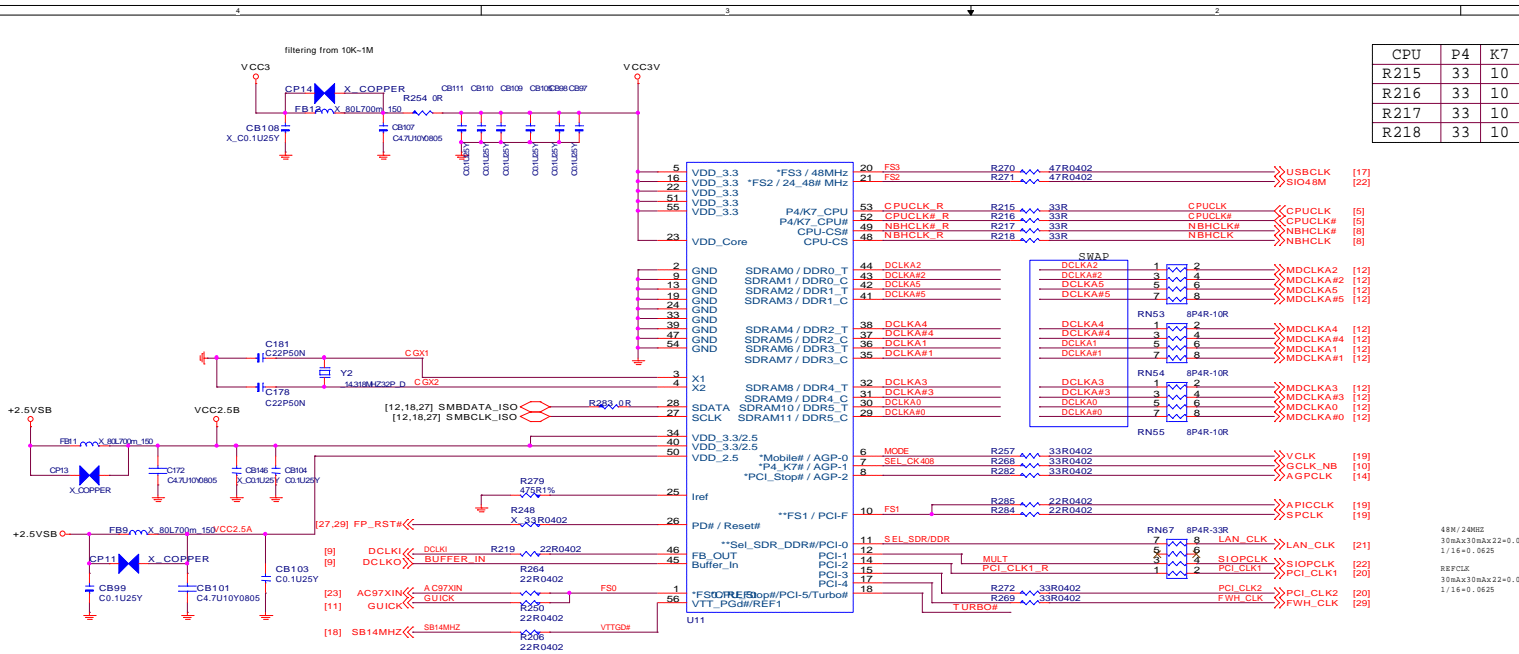

CPU	P4	K7
R215	33	10
R216	33	10
R217	33	10
R218	33	10

**Pull-Down Capacitors**

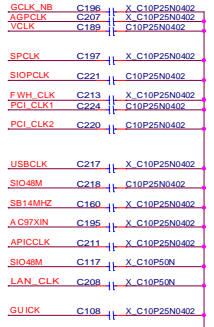

48M / 24MHz  
30nAx30nAx22+0.0198  
1/16+0.0625  
REFCLK  
30nAx30nAx22+0.0198  
1/24+0.0625

used only for EMI issue  
Trace less 0.2"

Transistor Q29 for Vtt\_PG is for Intel P4 use only !

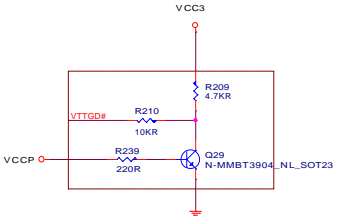

**Intel Table**

S3	S2	S1	S0	CPU
				Not Support
1	1	0	1	133
		1	0	200
		1	1	166

**CLOCK STRAPPING RESISTORS**

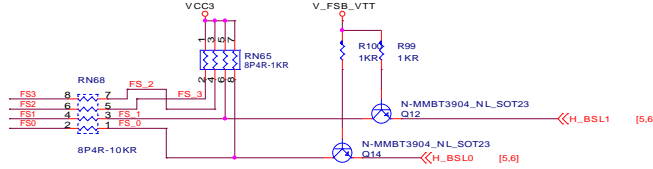

**Shut Source Termination Resistors**

- CPUCLK# R195 49.9R1%
- CPUCLK# R196 49.9R1%
- NBHCLK# R198 49.9R1%
- NBHCLK# R197 49.9R1%

For Intel P4 use only ! Trace less 0.2"

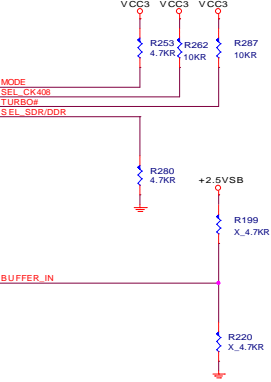

Keep these resistors to get better DDR compatibility

MODE	Pin 8	Pin 18
R253 X		
On xx	AGP_2	PCI_5/Turbo
xx On	PCI_Stop#	CPU_Stop#

SEL_CK408	Pin52/53
R262 X	
On xx	Current Mode
xx On	Open Drain

SEL_SDR/DDR	
Pull Hi	Select SDRAM
Pull Lo	Select DDR-SDRAM





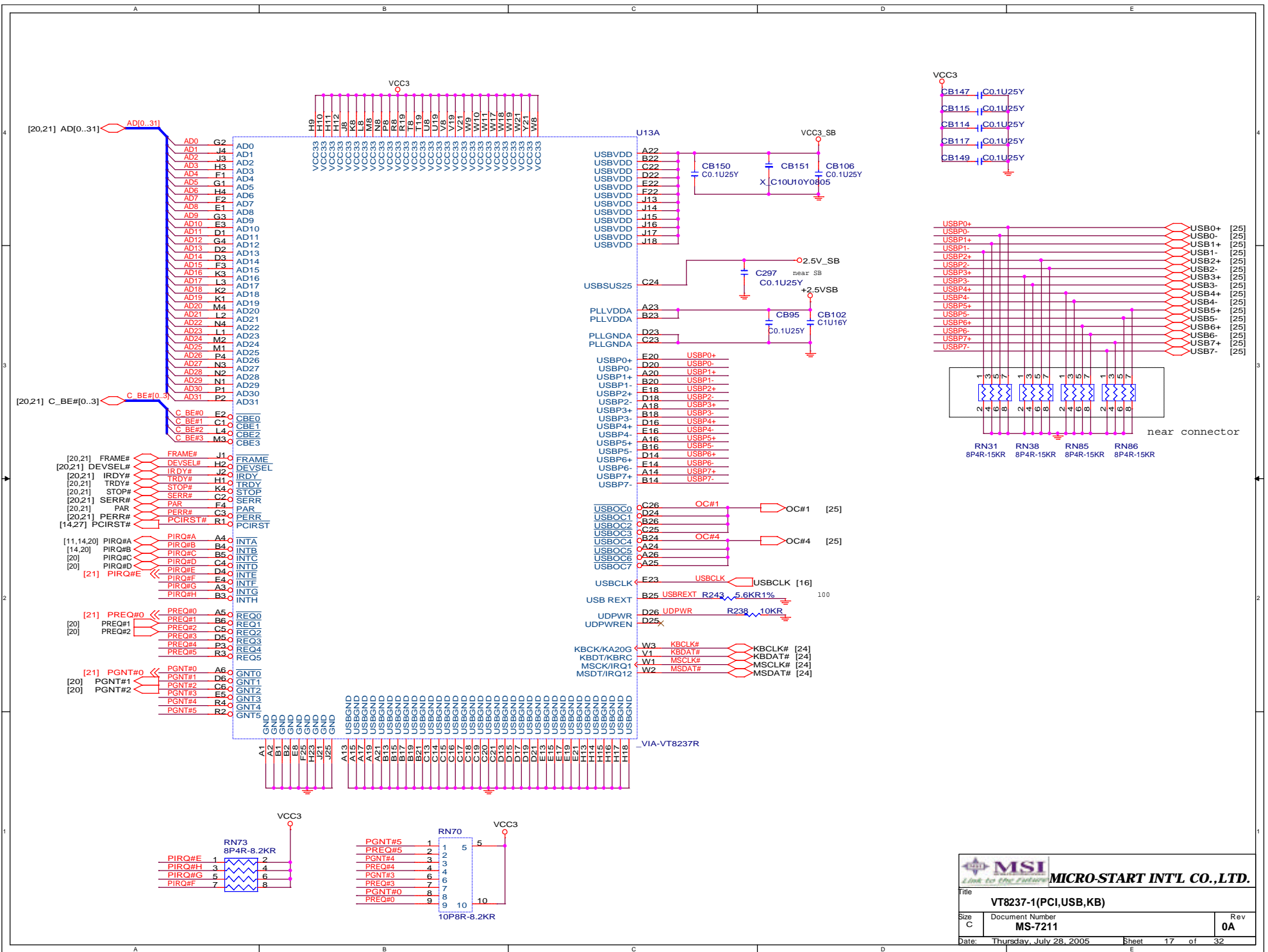

# SB Pull up resistors

# VT8237 strapping

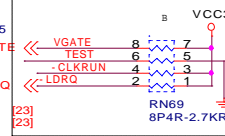
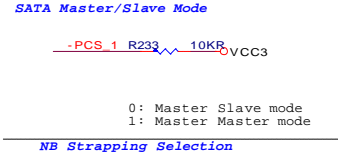
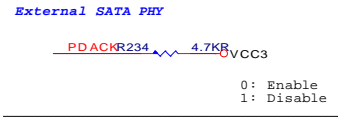
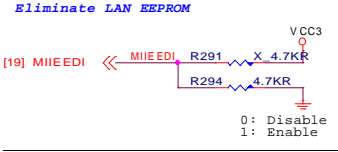
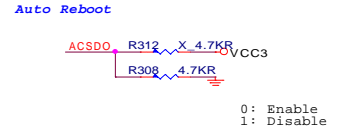
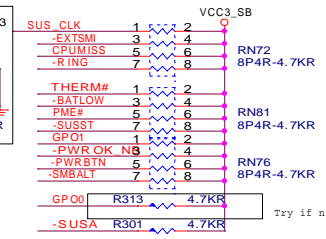
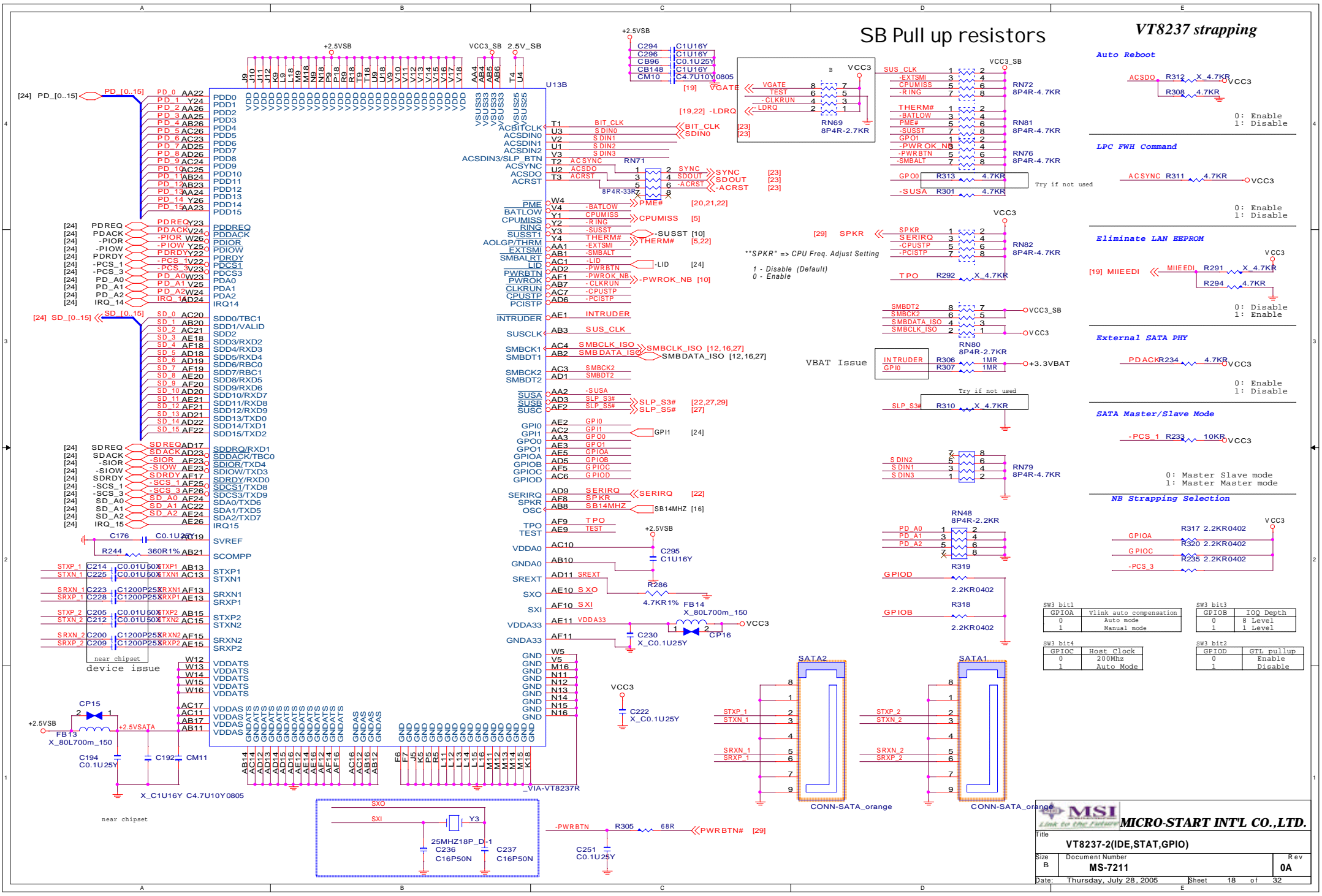

\*\*SPKR\* => CPU Freq. Adjust Setting  
 1 - Disable (Default)  
 0 - Enable

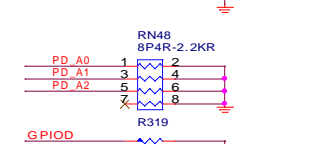
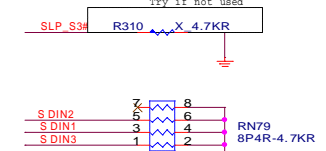
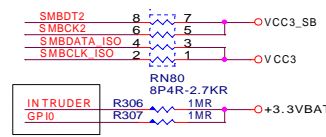
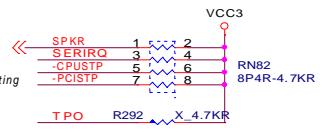

SW3 bit1	GPIOA	Vlink auto compensation	SW3 bit3	GPIOB	IOQ Depth
0	1	Auto mode	0	0	8 Level
1	1	Manual mode	1	1	1 Level

SW3 bit4	GPIOC	Host Clock	SW3 bit2	GPIOD	GTL pullup
0	1	200Mhz	0	0	Enable
1	1	Auto Mode	1	1	Disable

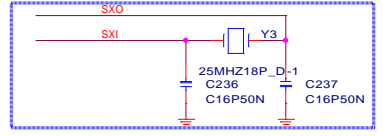
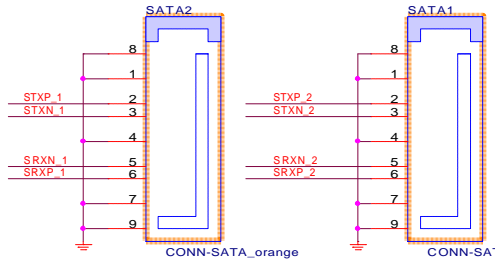

**MSI**  
 Link to the Future  
**MICRO-START INTL CO.,LTD.**

**VT8237-2(IDE,STAT,GPIO)**

Size B Document Number **MS-7211** Rev **0A**

Date: Thursday, July 28, 2005 Sheet 18 of 32

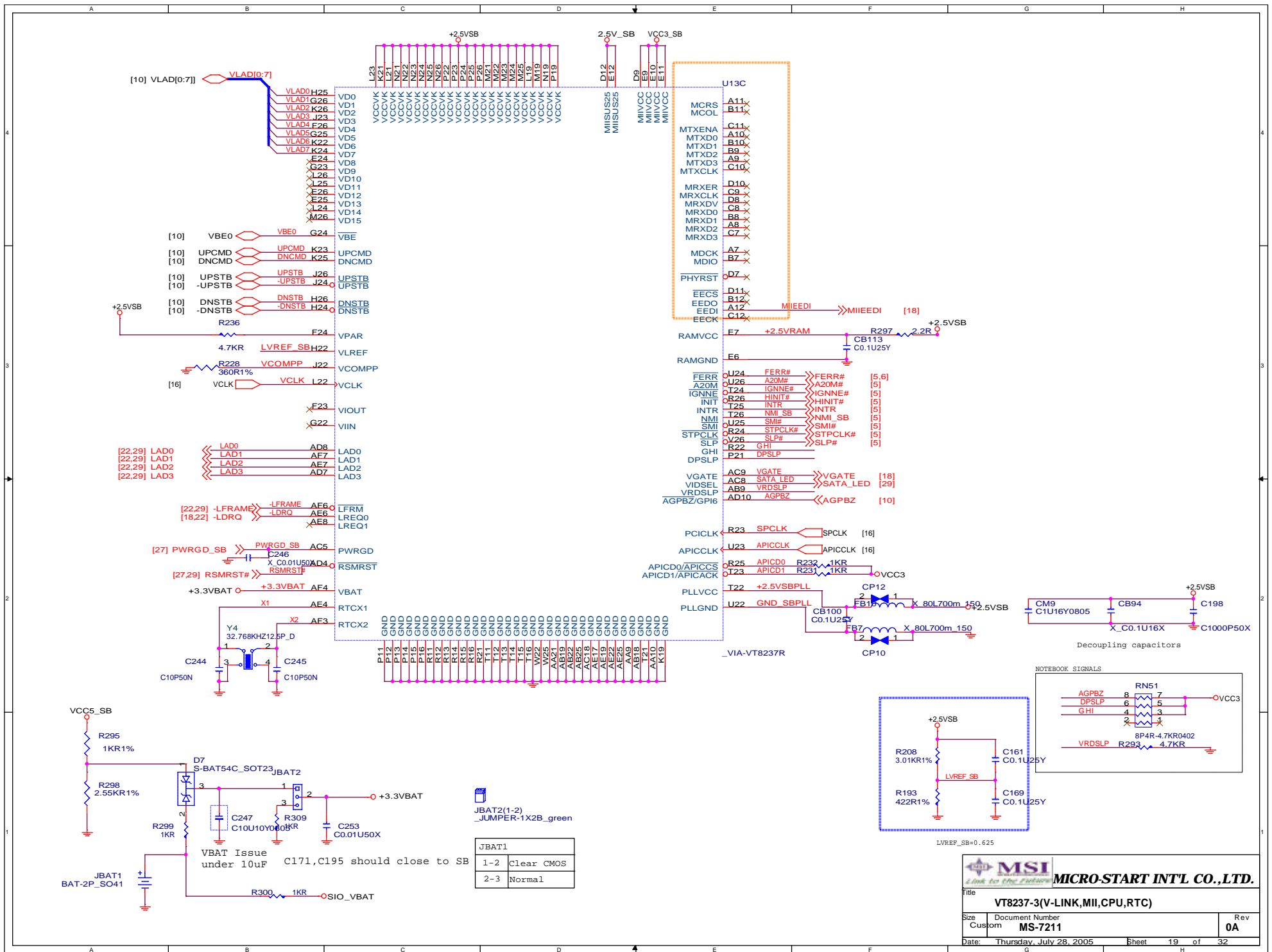

JBAT1

1-2	Clear CMOS
2-3	Normal

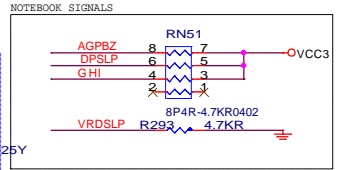

<b>MICRO-START INT'L CO.,LTD.</b>		
Title <b>VT8237-3(V-LINK,MII,CPU,RTC)</b>		
Size Custom	Document Number <b>MS-7211</b>	Rev <b>0A</b>
Date: Thursday, July 28, 2005	Sheet 19	of 32

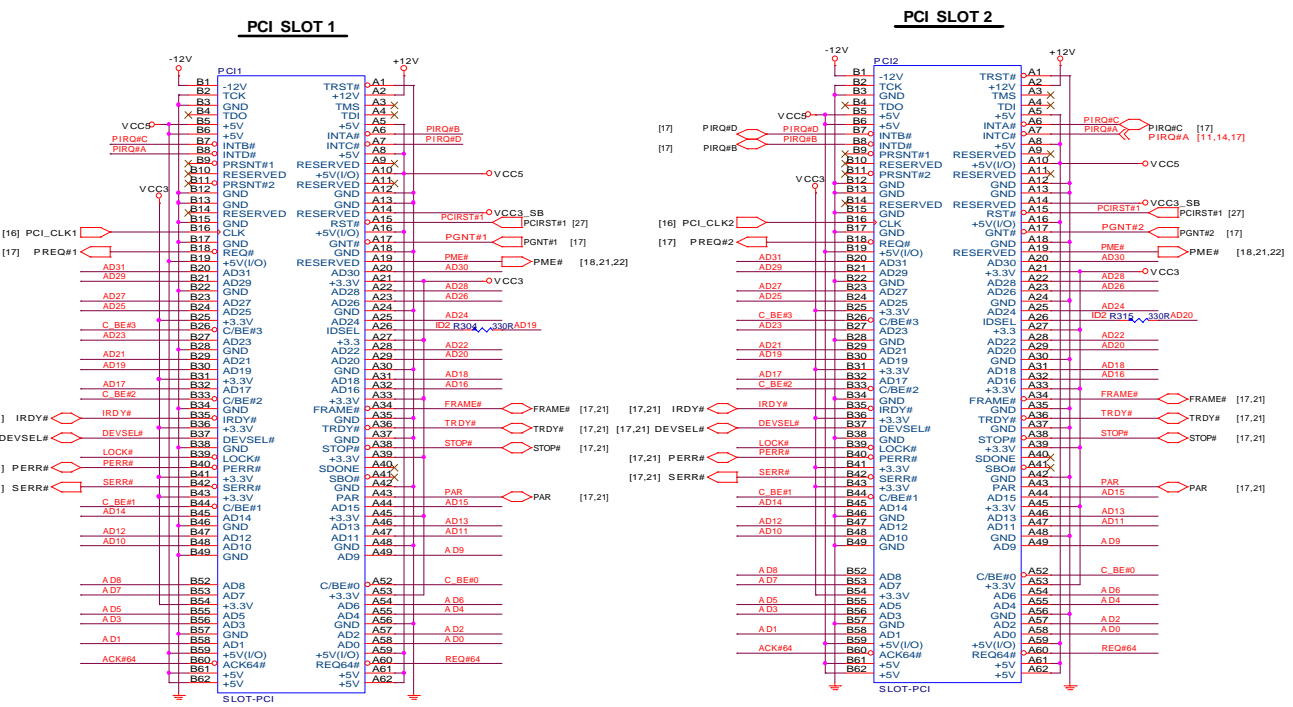

**PCI SLOT 1**  
**PCI SLOT 2**

**ISSEL = AD19**  
**MASTER = PREQ#1**  
**PIRQ#B**

**ISSEL = AD20**  
**MASTER = PREQ#2**  
**PIRQ#C**

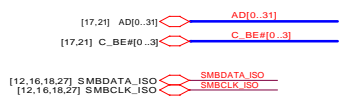

**PCI PULL-UP / DOWN RESISTORS**

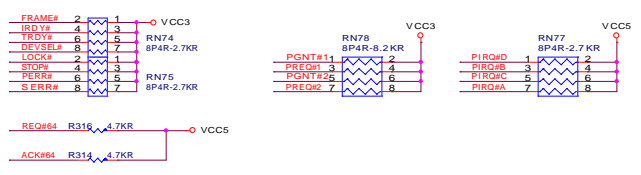

**PCI SLOT DECOUPLING CAPACITORS**

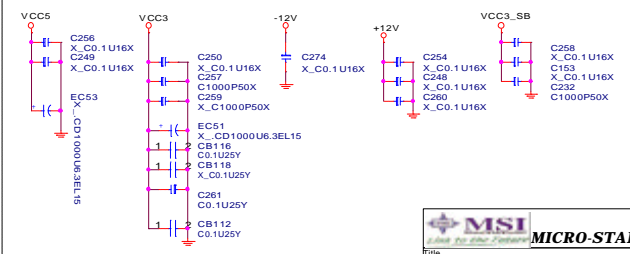

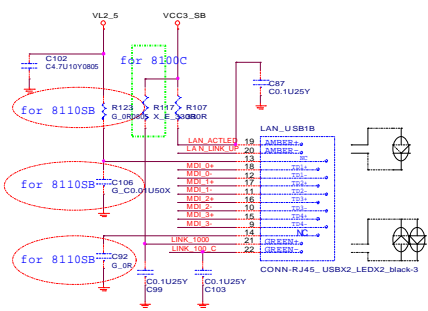
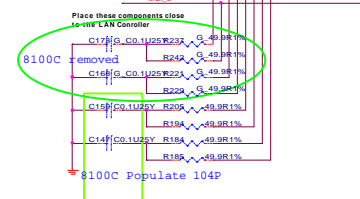
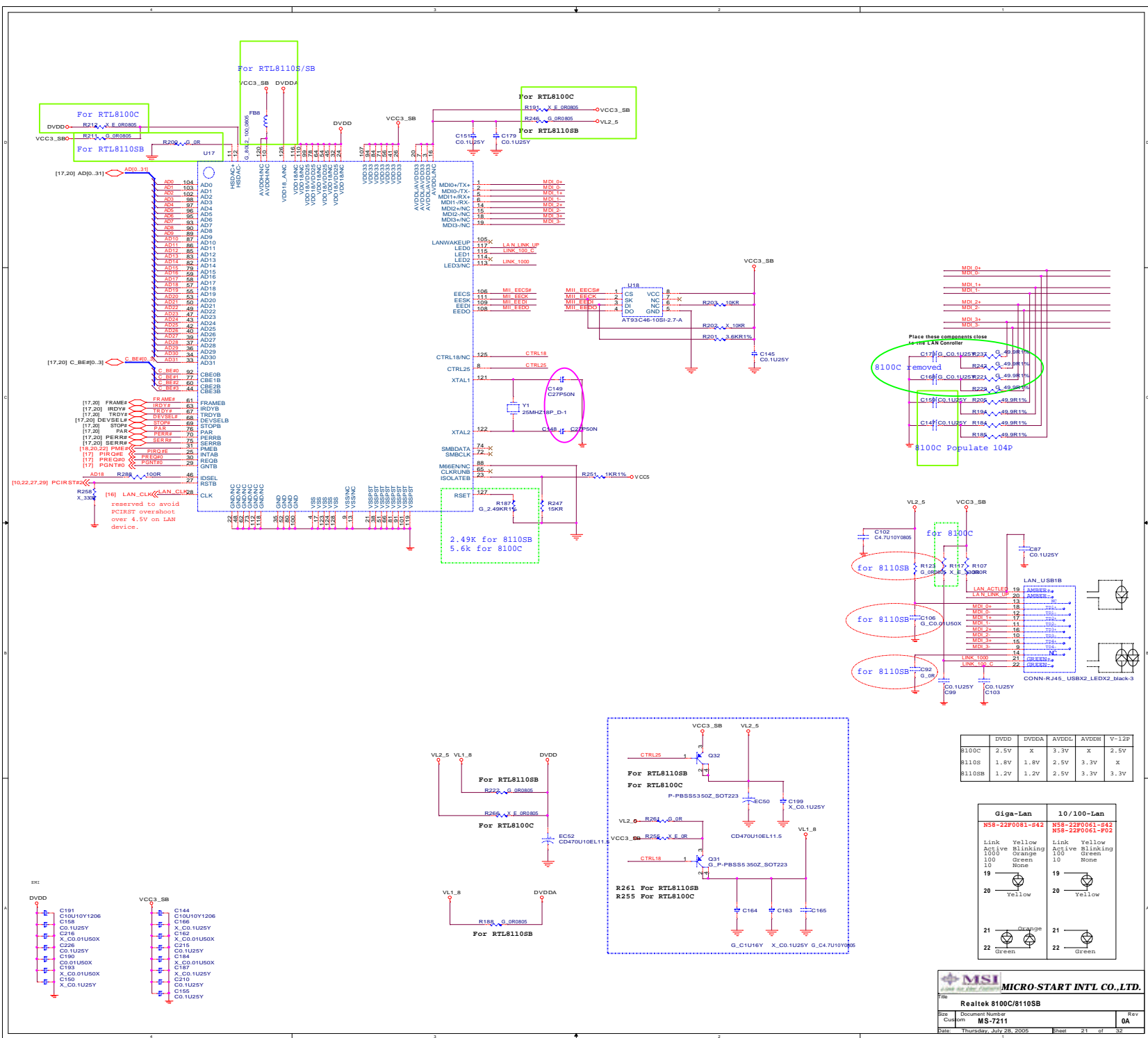

	DVDD	DVDDA	AVDDL	AVDDH	V-12P
8100C	2.5V	X	3.3V	X	2.5V
8110S	1.8V	1.8V	2.5V	3.3V	X
8110SB	1.2V	1.2V	2.5V	3.3V	3.3V

Giga-Lan		10/100-Lan	
N58-22P0081-842		N58-22P0061-842	
N58-22P0081-842		N58-22P0061-842	
Link	Yellow	Link	Yellow
Active	Blinking	Active	Blinking
100	Orange	100	Green
10	Green	10	None
19	None	19	Yellow
20	Yellow	20	Yellow
21	Orange	21	Yellow
22	Green	22	Green

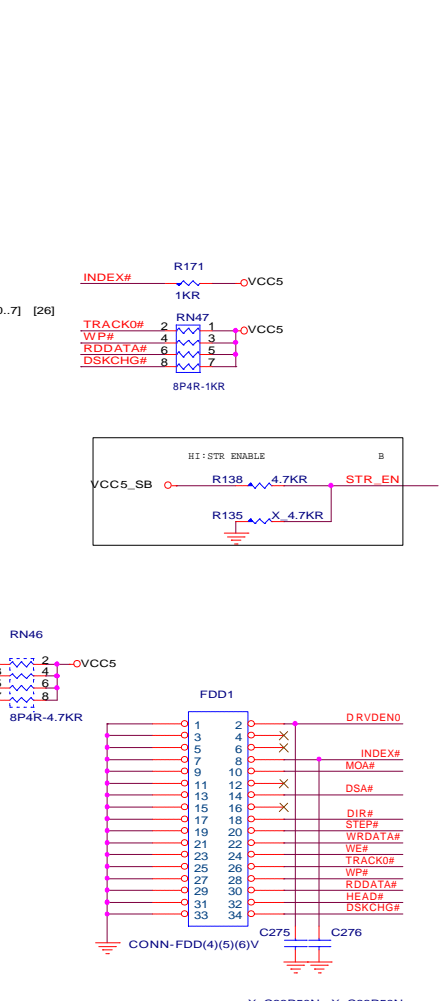
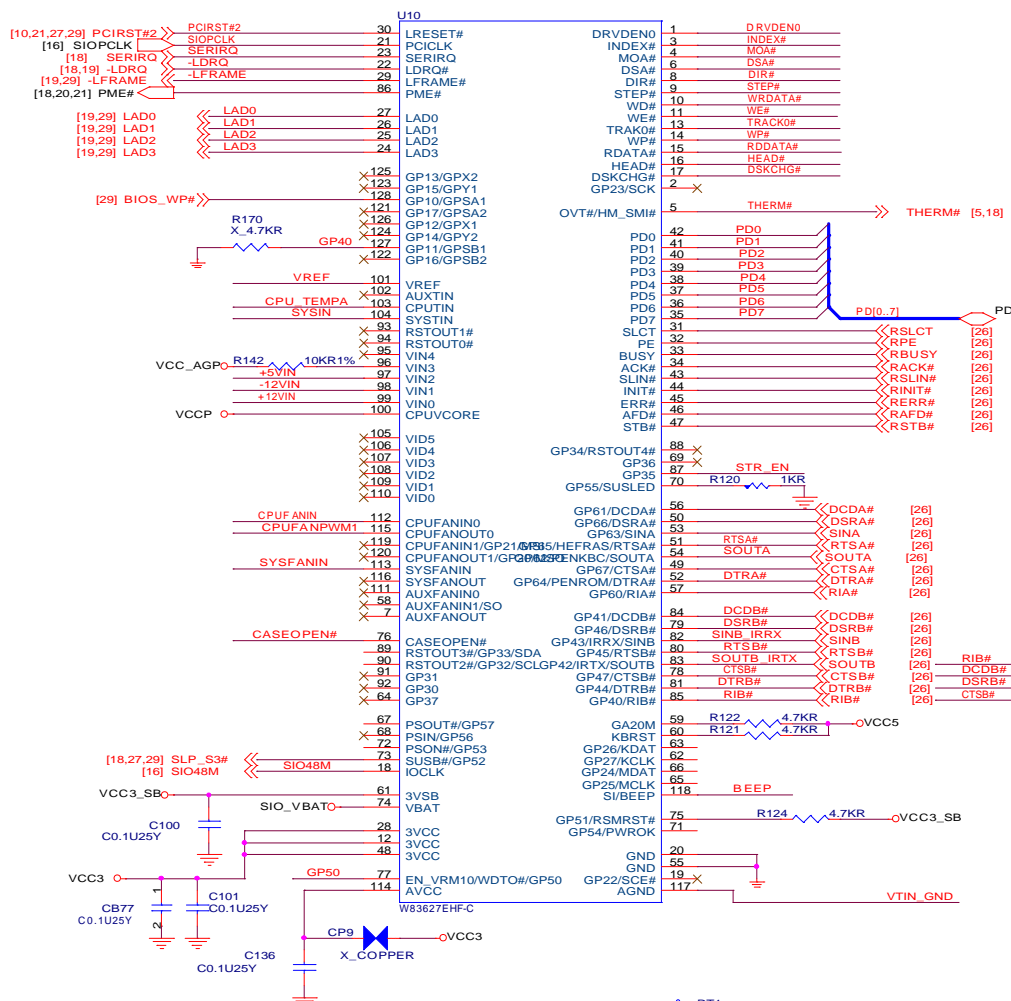

### CPU FAN

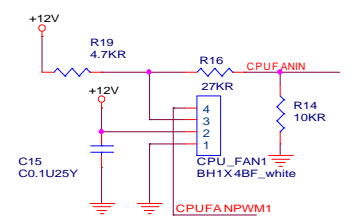

### SYS FAN

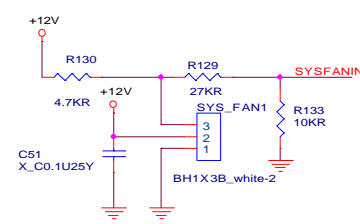

### PWR FAN

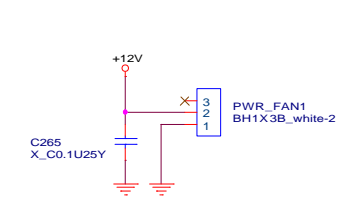

### Straps

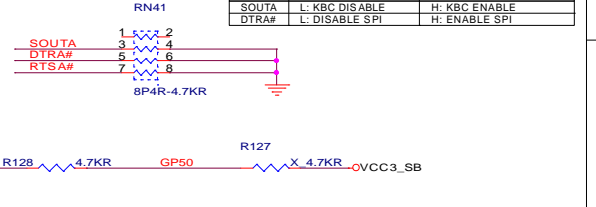

### Chassis Intrusion

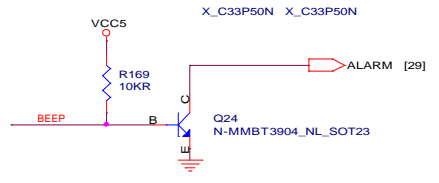
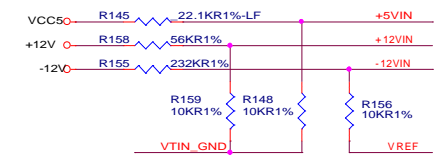
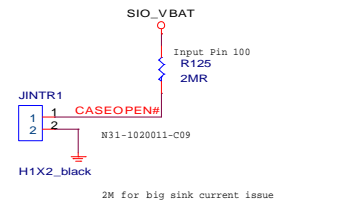

**MSI**  
**MICRO-START INT'L CO., LTD.**

File: Super I/O & FAN 83627EHF-D

Size: Custom    Document Number: MS-7211    Rev: 0A

Date: Thursday, July 28, 2005    Sheet: 22 of 32

2M for big sink current issue

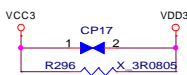

Pin46=floating---external clock  
=pull-low---from clock gen

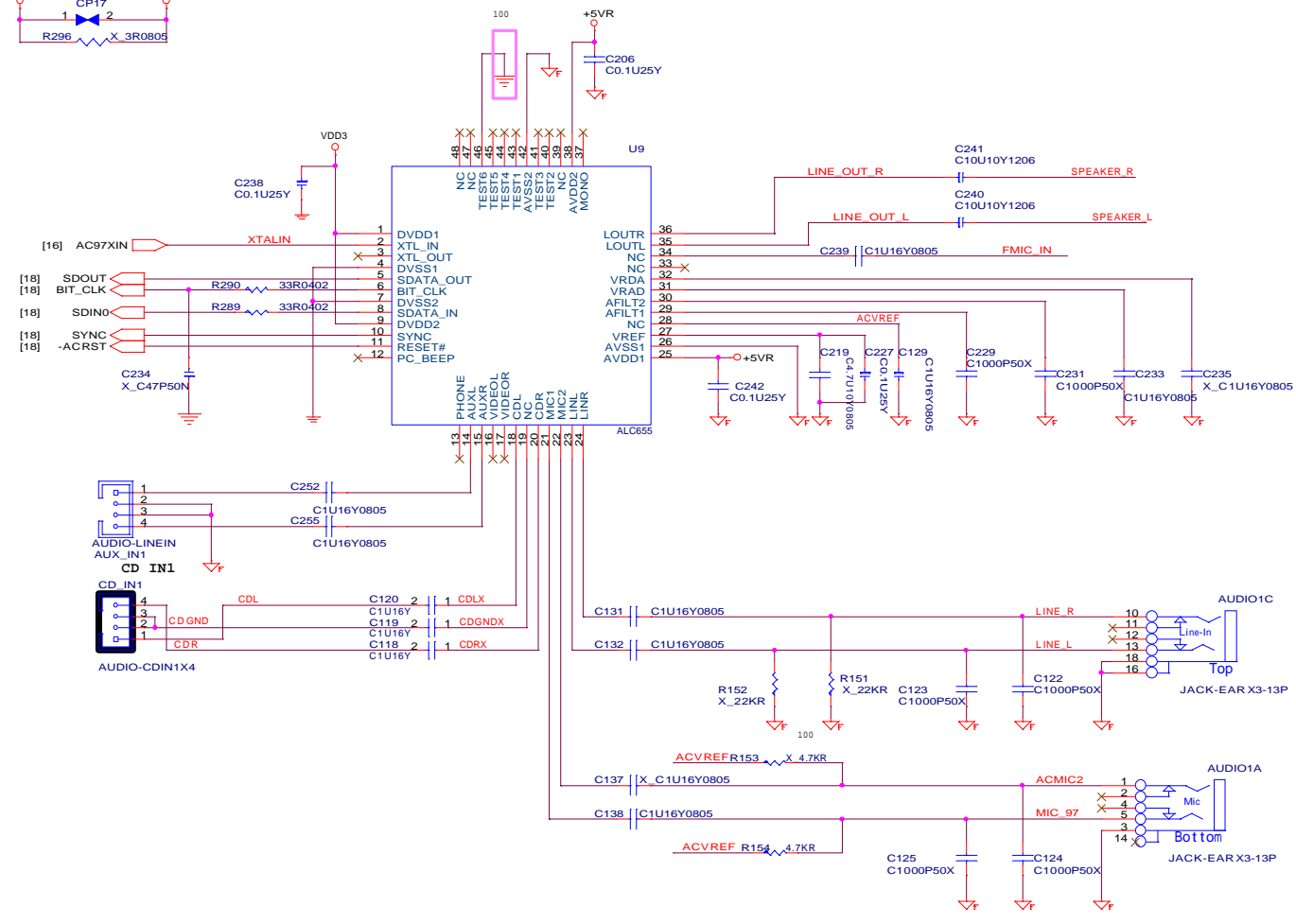

### AUDIO CODE REGULATORS

Trace Width 40mils.

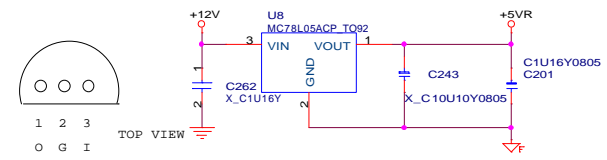

### Intel Front Audio Connector

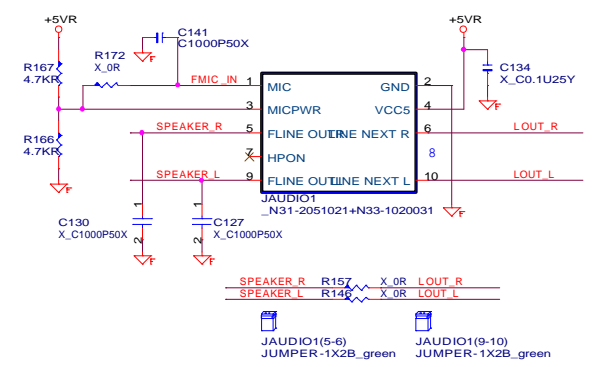

### For EMI

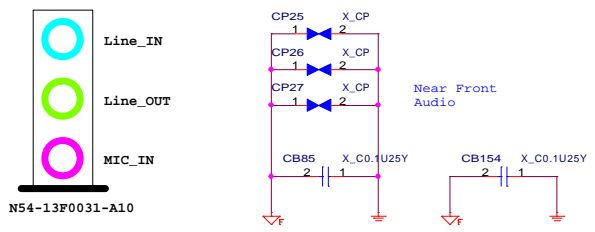

### SPEAKER OUT JACK

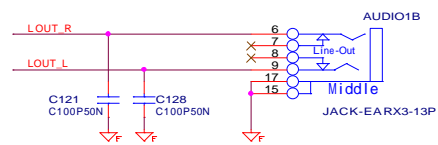

**MSI**  
**MICRO-START INT'L CO.,LTD.**  
 Title: **AC97 Realtex ALC655**  
 Size: Custom    Document Number: **MS-7211**    Rev: **0A**  
 Date: Thursday, July 28, 2005    Sheet: 23 of 32



# IDE1 AND IDE2

## PRIMARY

## SECONDARY

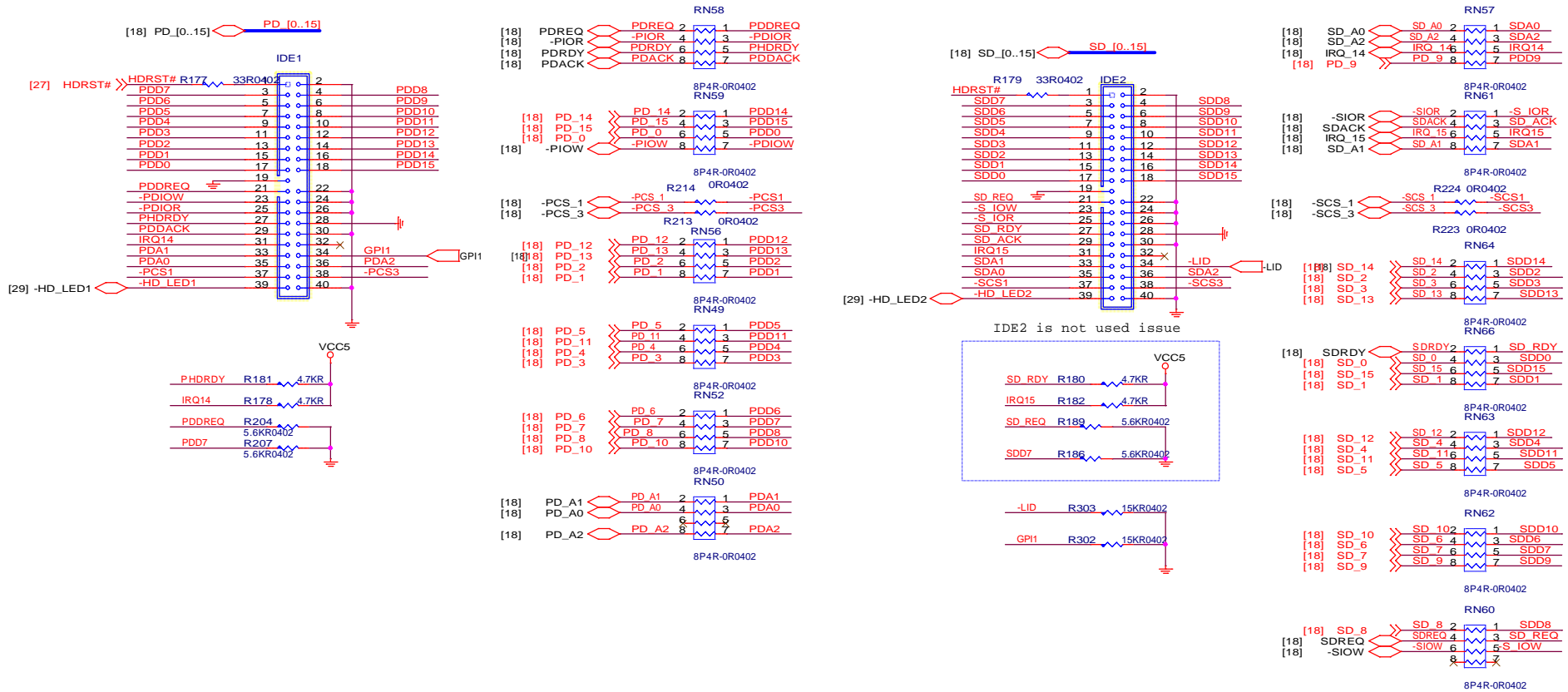

# PS2 KB/MS

## EMI

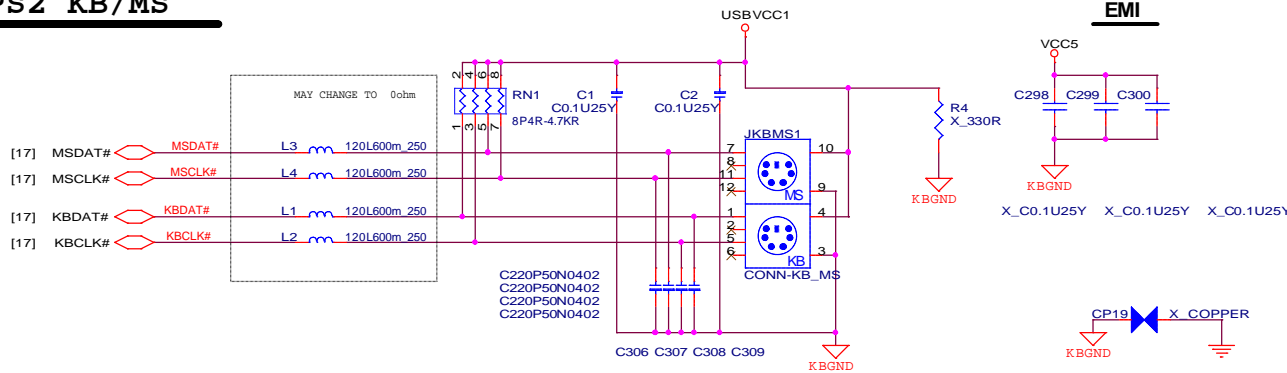



### Rear USB Connectors

43m08M X 2 A= 66mV

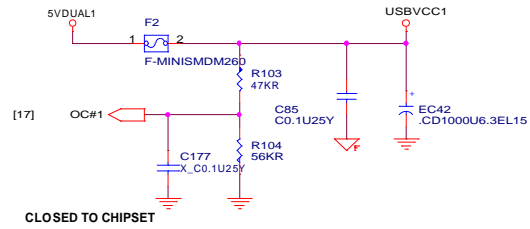

### Front USB Connectors

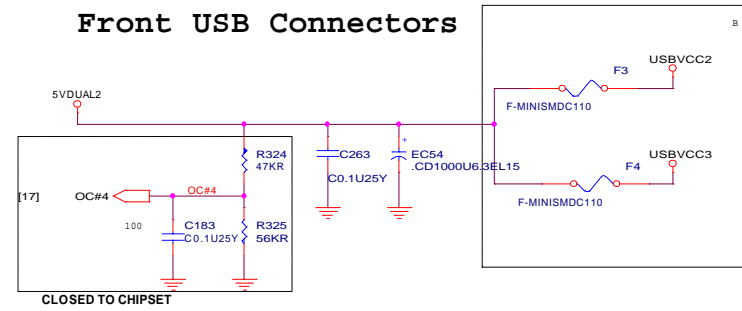

### REAR PANEL USB CONNECTOR FOR USB PORT 0,1

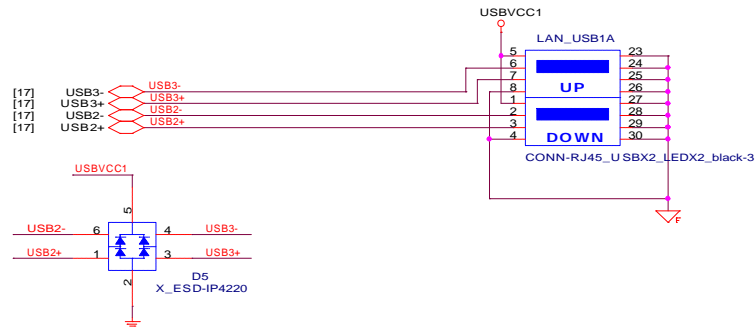

### FRONT PANEL USB CONNECTOR FOR USB PORT 4,6

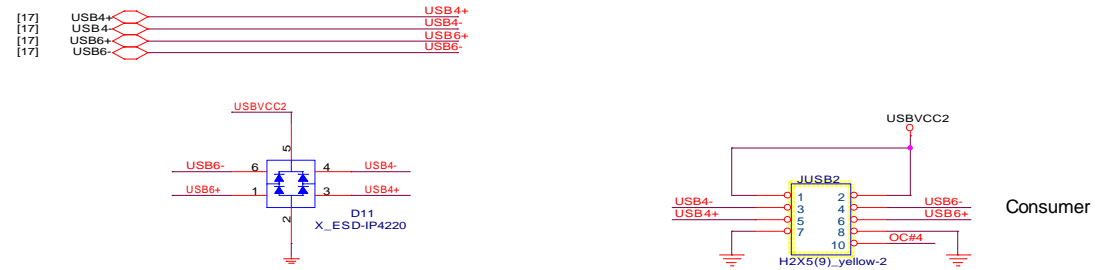

### REAR PANEL USB CONNECTOR FOR USB PORT 2,3

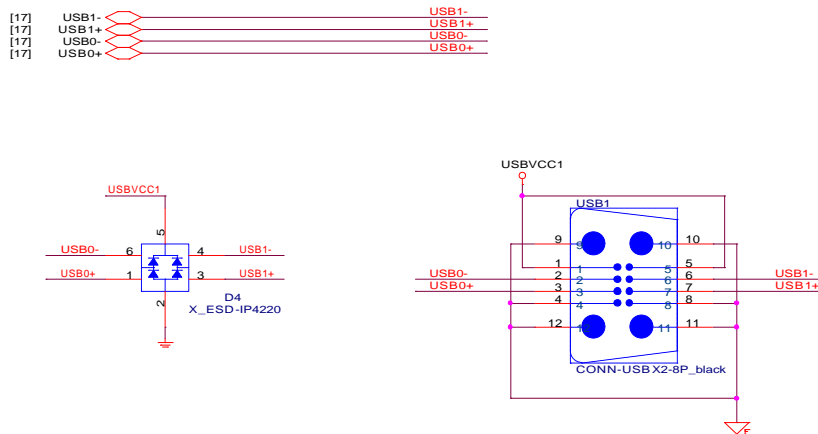

### FRONT PANEL USB CONNECTOR FOR USB PORT 5,7

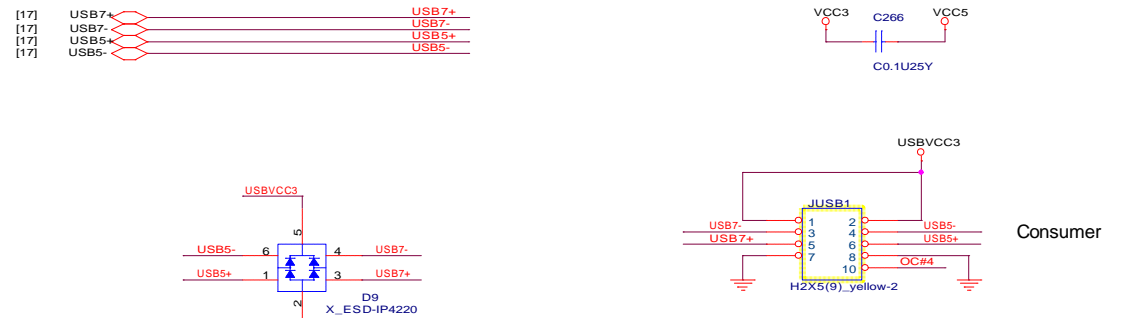

# PRINTER/COM PORT

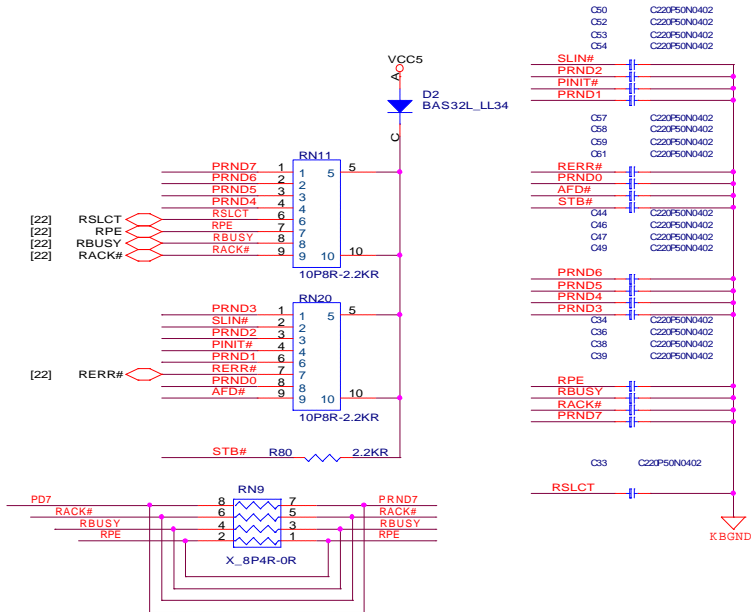
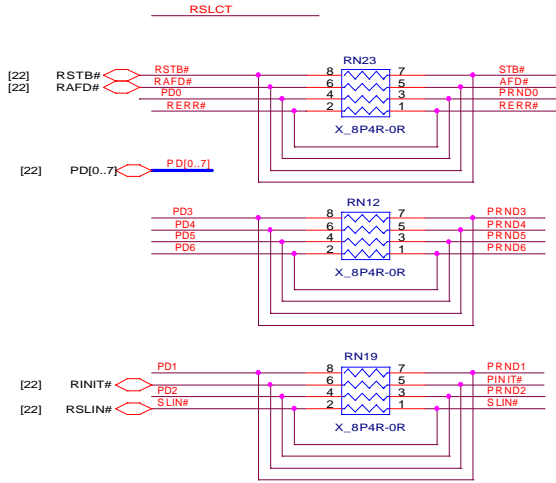

# PARALLAL PORT

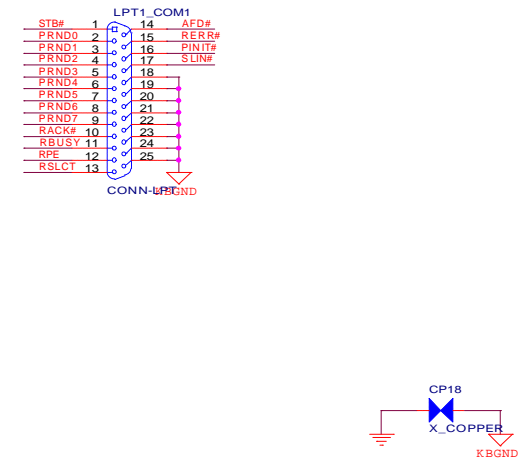

# SERIAL PORT 2

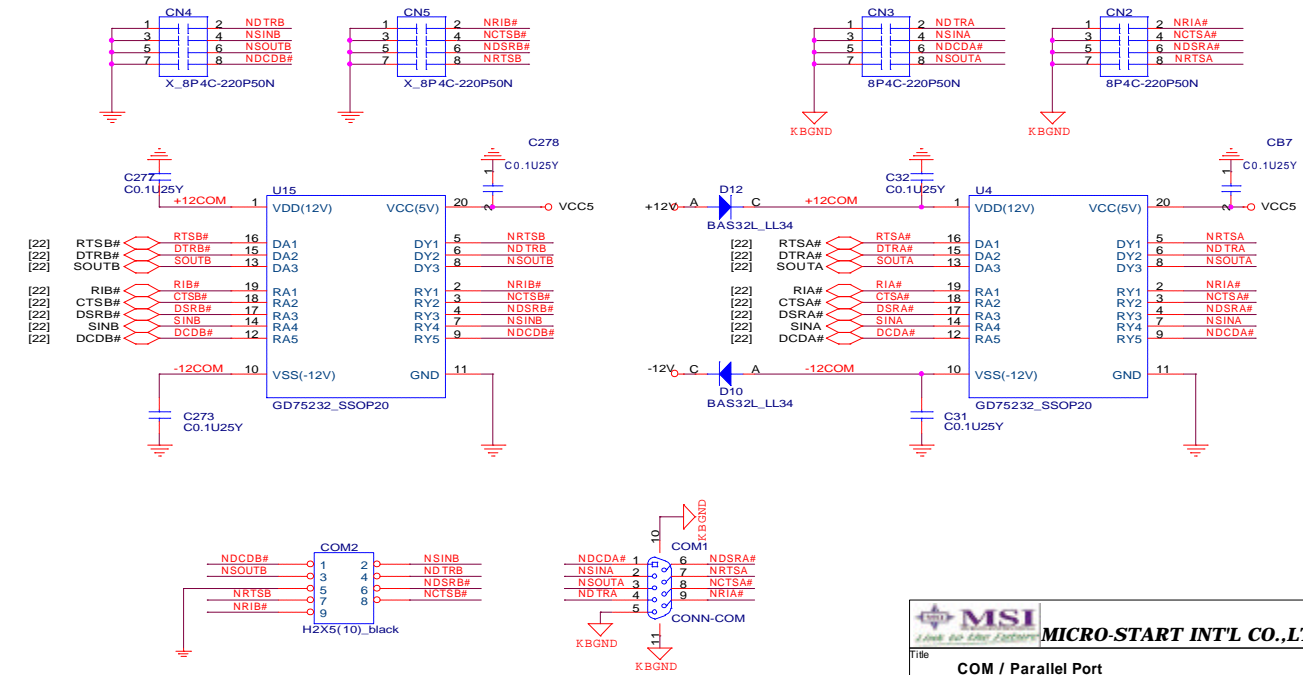

Gate Trace 8 mils  
Sense Trace 8 mils

### 3VSB MODE SELECT

3VSB MODE	3VLDDEC#
SINGLE MOSFET	PULL HIGH
DUAL MOSFET	PULL LOW

### VDIMM LINEAR OR PWM SELECT

VDIMM MODE	EXTRAM
LINEAR REGULATOR	PULL LOW
PWM REGULATOR	PULL HIGH

MOS	R <sub>ds(on)</sub>	V <sub>ds</sub>	V <sub>gs</sub>	I <sub>d</sub>	Package	Qg
P07N03LV	25.0m	30V	20V	7A	SO-8	13
APM7313	28.0m	30V	20V	6A	SO-8	20
P3055LD	90.0m	25V	20V	12A	TO-252	20
P45N02LD	28.0m	25V	20V	45A	TO-252	30
P50N03LD	12.0m	27V	20V	50A	TO-252	50
NDS351	117m	30V	20V	2.5A	SOT-23	4
2N7002	7.5	60V	20V	115mA	SOT-23	
PHKD6N02LT	20.0m	20V	12V	6A	SO-8	20

### 5V Dual Power

Rear USB ports

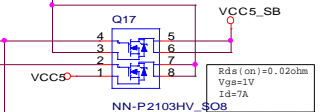

Front USB ports

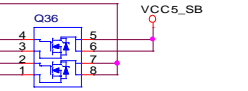

8237 VCC3 should lead VCC2.5 by 1.5 ~ 2ms

$$1.2 (R1/R2+1) = VOL$$

MS-7

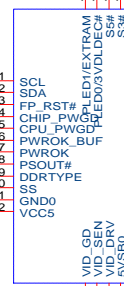

### 2.5V\_SB Power

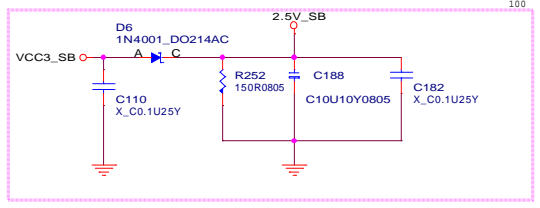

### DDR VTT Power

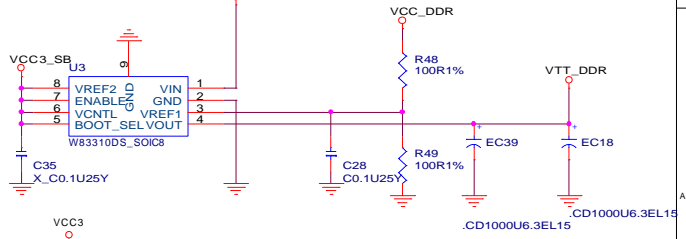

**MSI**  
Link to Life

**MICRO-START INT'L CO.,LTD.**

Title: **MS7 ACPI Controller**

Size	Document Number	Rev
Custom	<b>MS-7211</b>	<b>0A</b>

Date: Thursday, July 28, 2005 Sheet 27 of 32

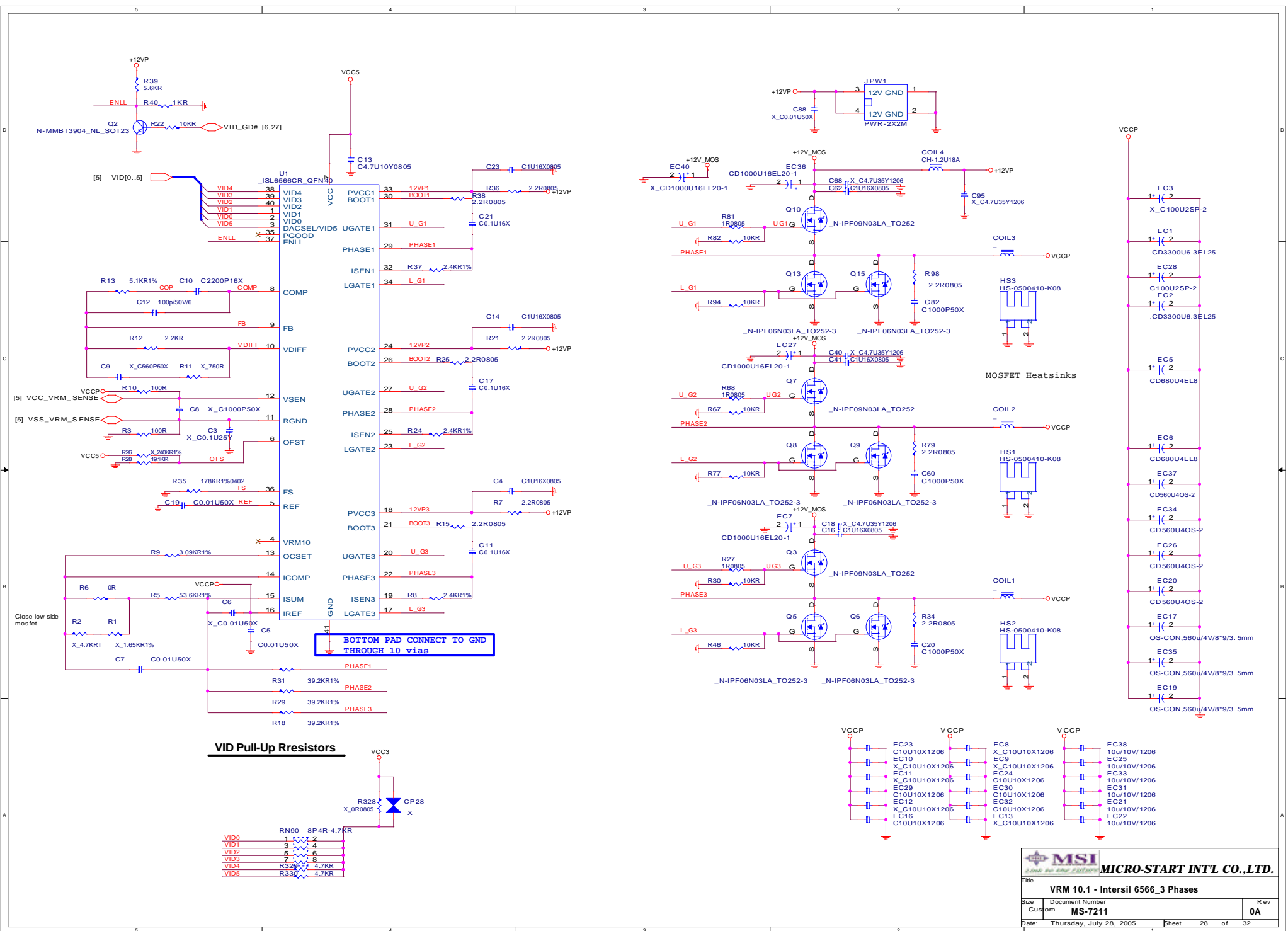

**VID Pull-Up Resistors**

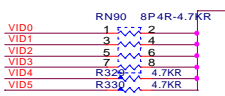

<b>MICRO-START INT'L CO.,LTD.</b>		
Title <b>VRM 10.1 - Intersil 6566_3 Phases</b>		
Size	Document Number	Rev
Custom	<b>MS-7211</b>	<b>0A</b>
Date:	Thursday, July 28, 2005	Sheet 28 of 32

# ATX CONNECTOR

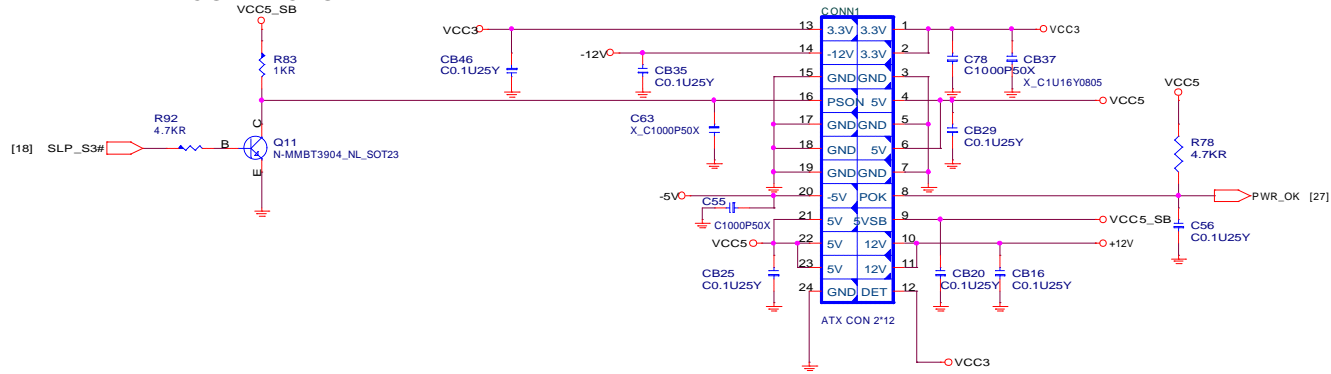

# Intel Front Panel

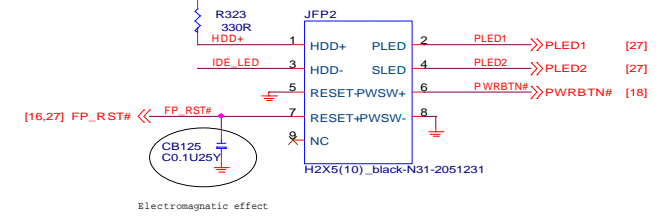

# SPEAKER

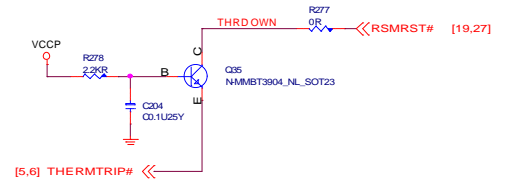
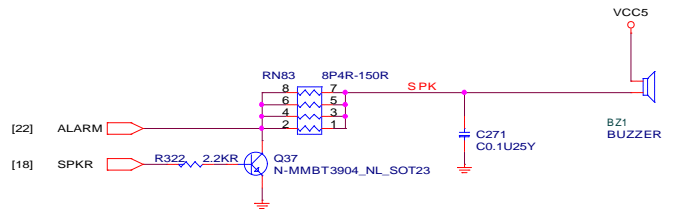

# Flash Rom

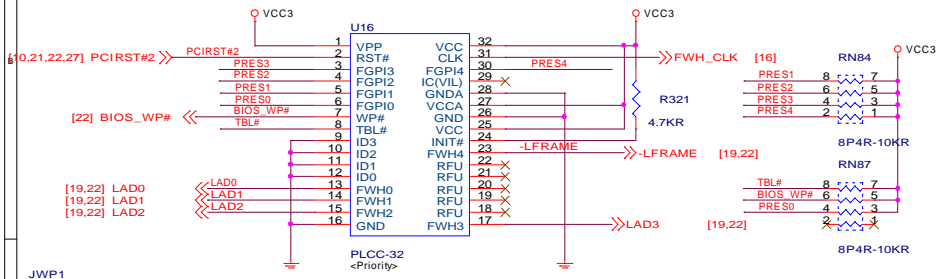

# FWH DECOUPLING CAPACITORS

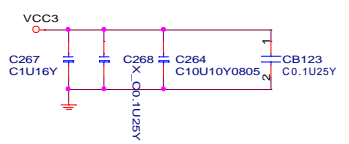

Place Cap. as Close to FWH < 350 mil

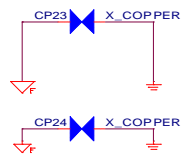

# HDD LED

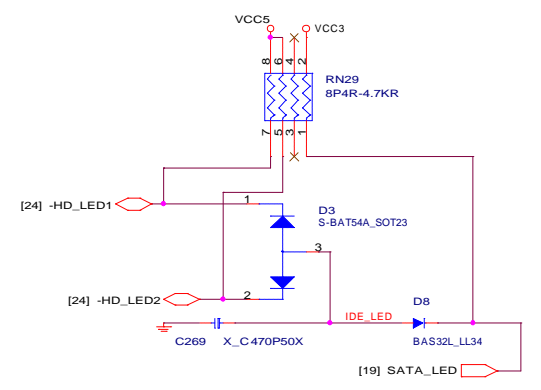

Title <b>ATX &amp; F_Panel &amp; BIOS</b>		
Size Custom	Document Number <b>MS-7211</b>	Rev <b>0A</b>
Date: Thursday, July 28, 2005	Sheet 29 of 32	

**PCB OTHER COMPONENT**

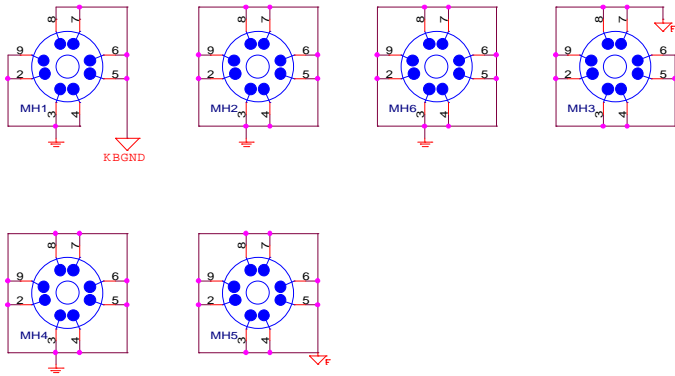

**FIDUCIALS**

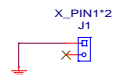
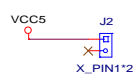
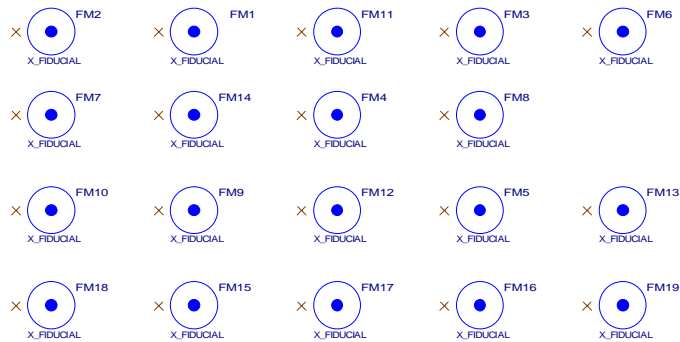

**EMI**

