

Voltage Rails

Voltage	Description	Control Signal
PWR_SRC	AC ADAPTER OR BATTERY IN	
VH CORE	Core Voltage for Processor	VR_ON
VTT	1.05 rail for Processor & 965GM I/O	RUN_ON
+1_5VRUN	1.5V switched power rail (off in S3-S5)	RUN_ON
+3VRUN	3.3V switched power rail (off in S3-S5)	RUN_ON
+5VRUN	5.0V switched power rail (off in S3-S5)	RUN_ON
SMDDR_VTERM	0.9V DDR Termination voltage (off in S3-S5)	RUN_ON
+1_8VDIMM	1.8V power rail DDR (off in S4-S5)	DIMM_ON
+3VSUS	3.3V power rail (off in S4-S5)	SUS_ON
+5VSUS	5.0V power rail (off in S4-S5)	SUS_ON
+3VALW	3.3V always on power rail	PWR_SRC
+5VALW	5.0V always on power rail	PWR_SRC
ADD5V	5.0V Power rail Audio codec(off in S3-S5)	+5VRUN
+VGFX_CORE	Graphic core of GMCH switched power rail (off in S3-S5)	GFX_VR_EN

POWER STATES

SIGNAL STATE	SLP_S3#	SLP_S4#	SLP_S5#	+V*ALWAYS	+V*SUS	+V*RUN	Clocks
S0(Full ON)	HIGH	HIGH	HIGH	ON	ON	ON	ON
S1M(Power On Suspend)	HIGH	HIGH	HIGH	ON	ON	ON	OFF
S3(Suspend to RAM)	LOW	HIGH	HIGH	ON	ON	OFF	OFF
S4(Suspend to Disk)	LOW	LOW	HIGH	ON	OFF	OFF	OFF
S5 / Soft OFF	LOW	LOW	LOW	ON	OFF	OFF	OFF

Note : WHEN AC MODE , System turn on then +V*SUS will always keep high

MSI CORPORATION			
Title			
PLATFORM			
Size	Document Number	Rev	
Custom	MS-1331	0A	
Date:	Wednesday, August 22, 2007	Sheet	2 of 40

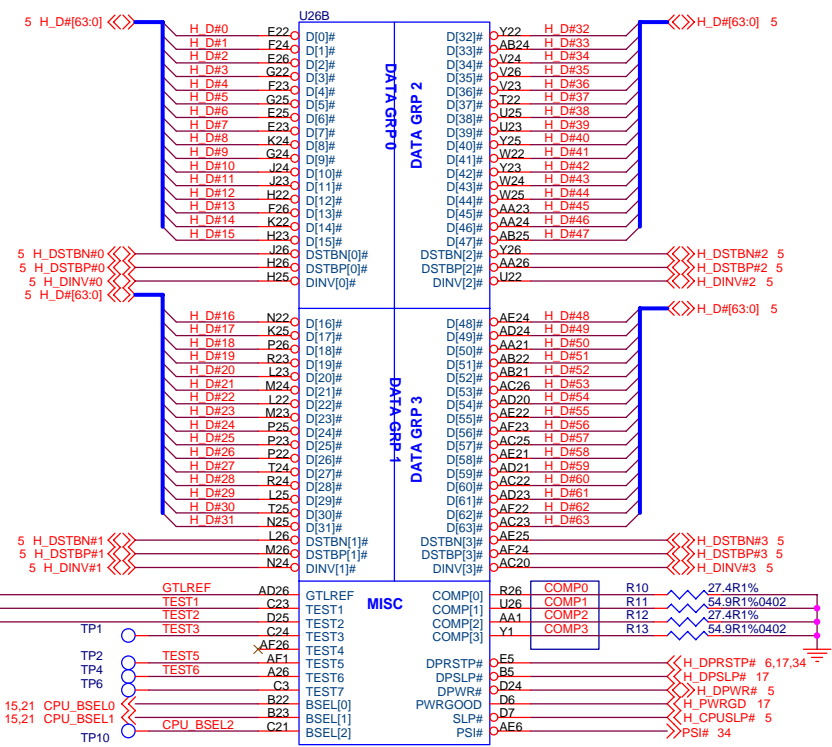
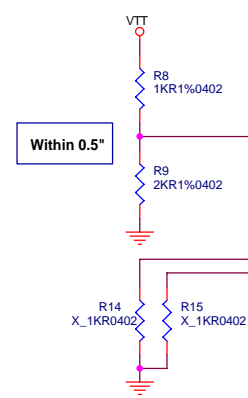
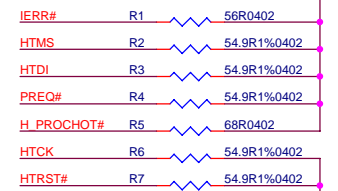
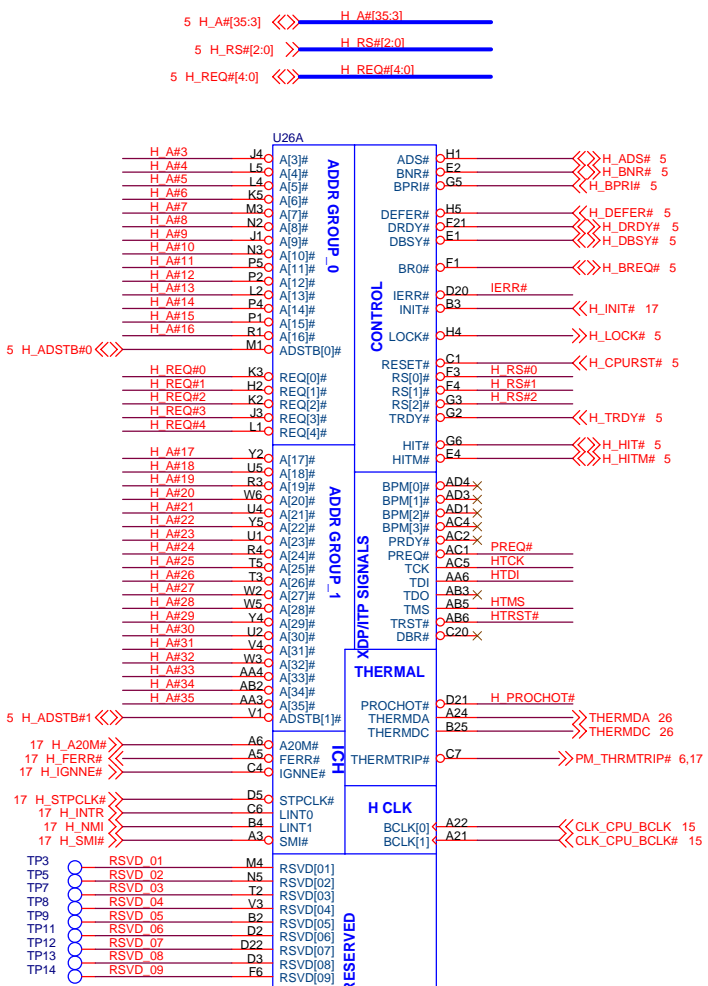

Within 0.5"
25mils Spacing
COMP0,2 -> 18mils
COMP1,3 -> 5mils

MSI CORPORATION			
Title PENRYN-1 (HOST BUS)			
Size	Document Number	Rev 0A	
Custom	MS-1331		
Date:	Wednesday, August 22, 2007	Sheet	3 of 40

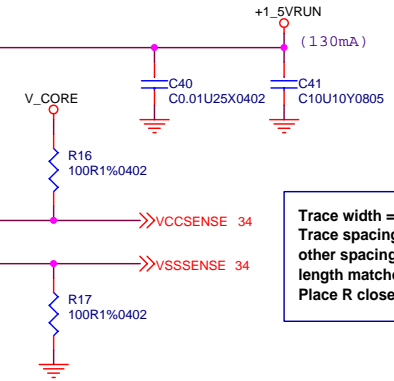
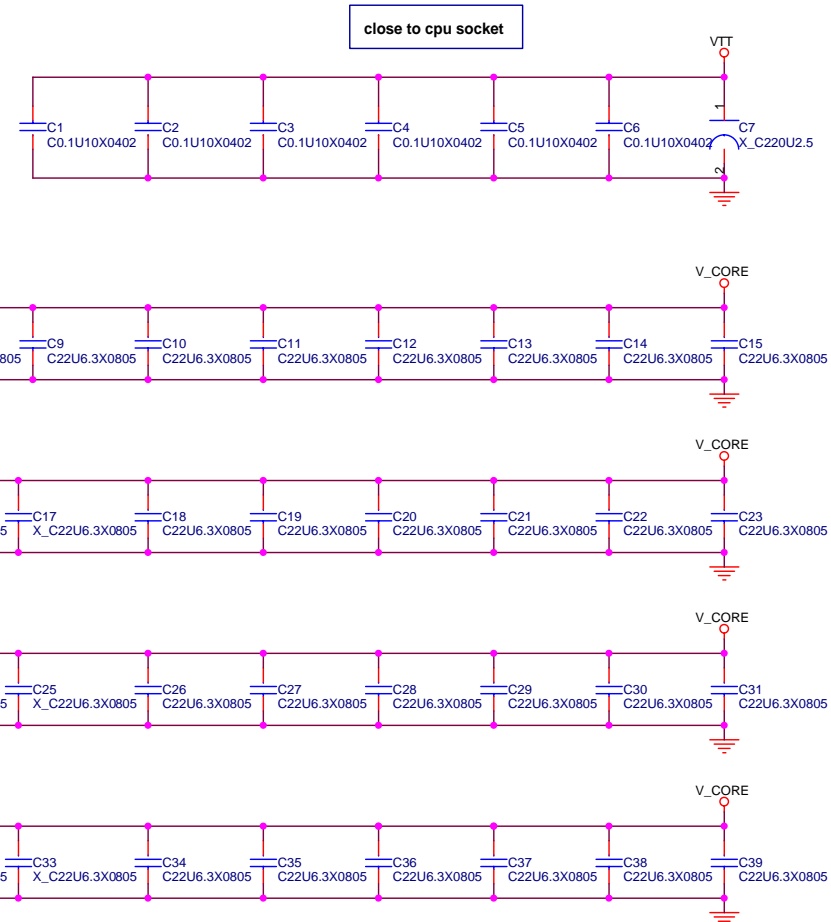
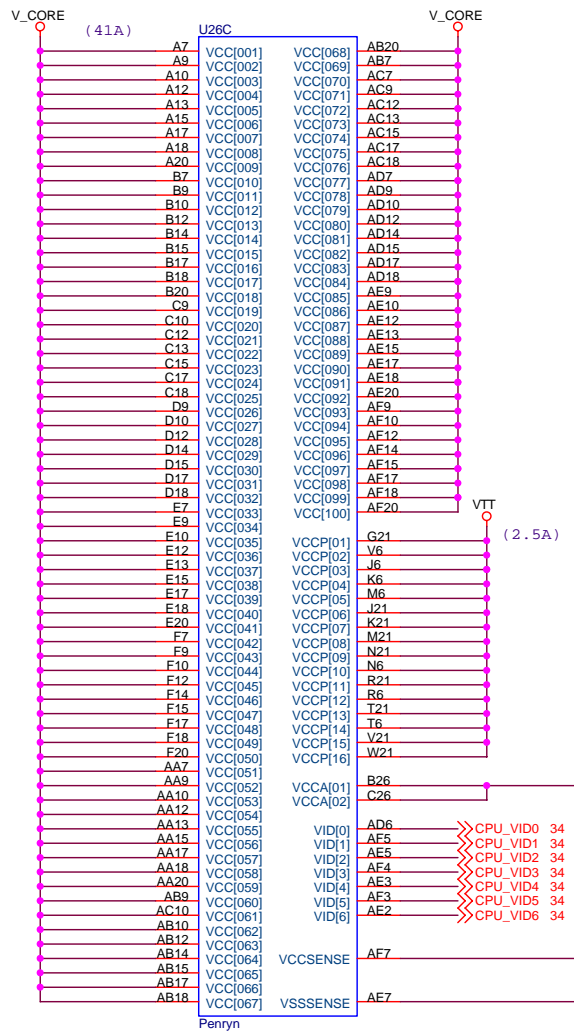
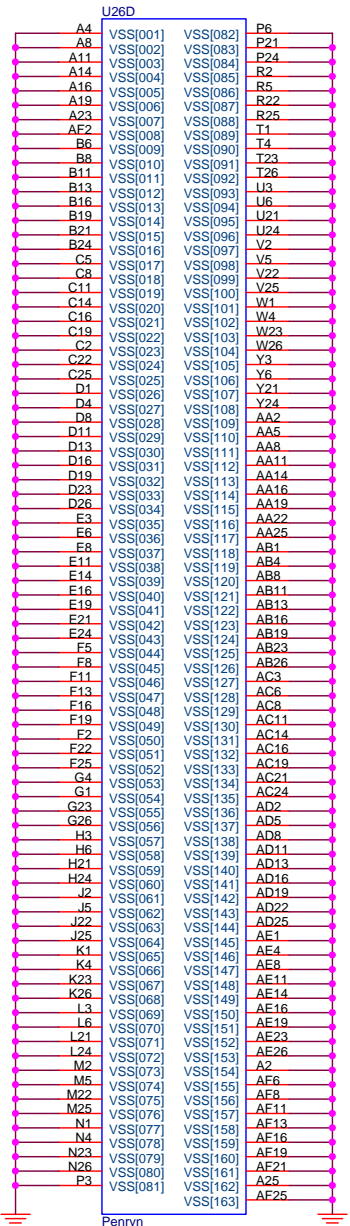

Place Cap close to pin
Trace width > 20

Trace width = 18mils
Trace spacing = 7mils
other spacing = 50mils
length matched within 25mils
Place R close to CPU within 1"

MSI CORPORATION		
PENRYN-2 (POWER/GND)		
Title	Document Number	Rev
Custom	MS-1331	0A
Date: Wednesday, August 22, 2007	Sheet	4 of 40

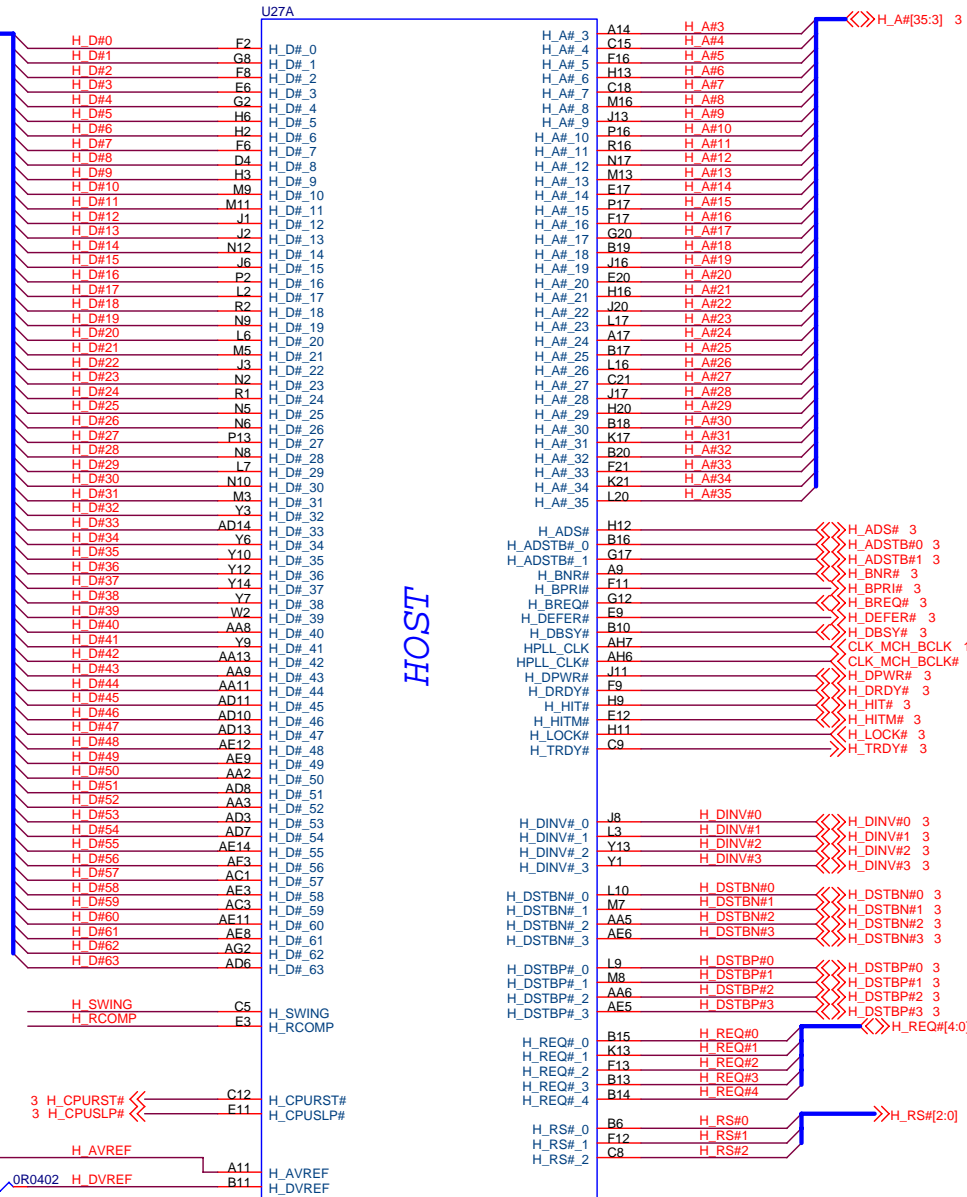
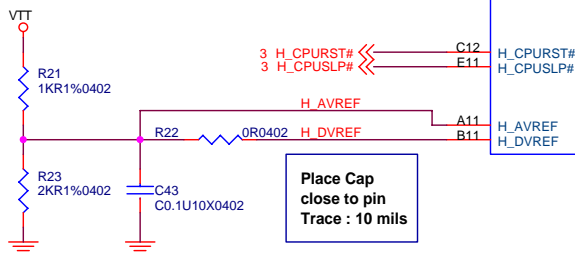
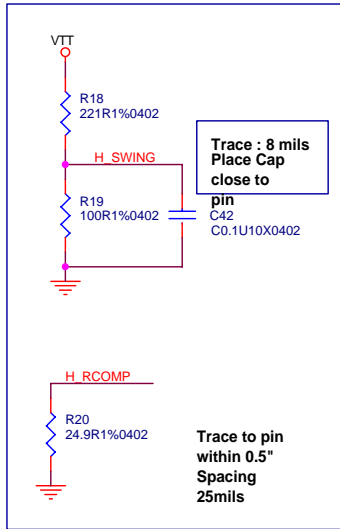

HOST

MSI CORPORATION		
CANTIGA-1 (HOST BUS)		
Title		
Size	Document Number	Rev
B	MS-1331	0A
Date:	Wednesday, August 22, 2007	Sheet 5 of 40

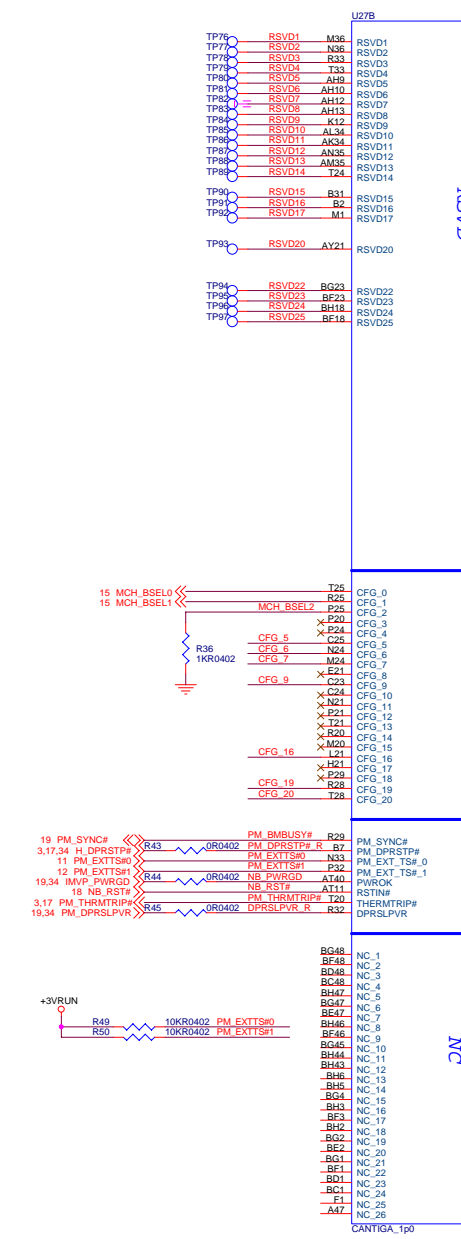

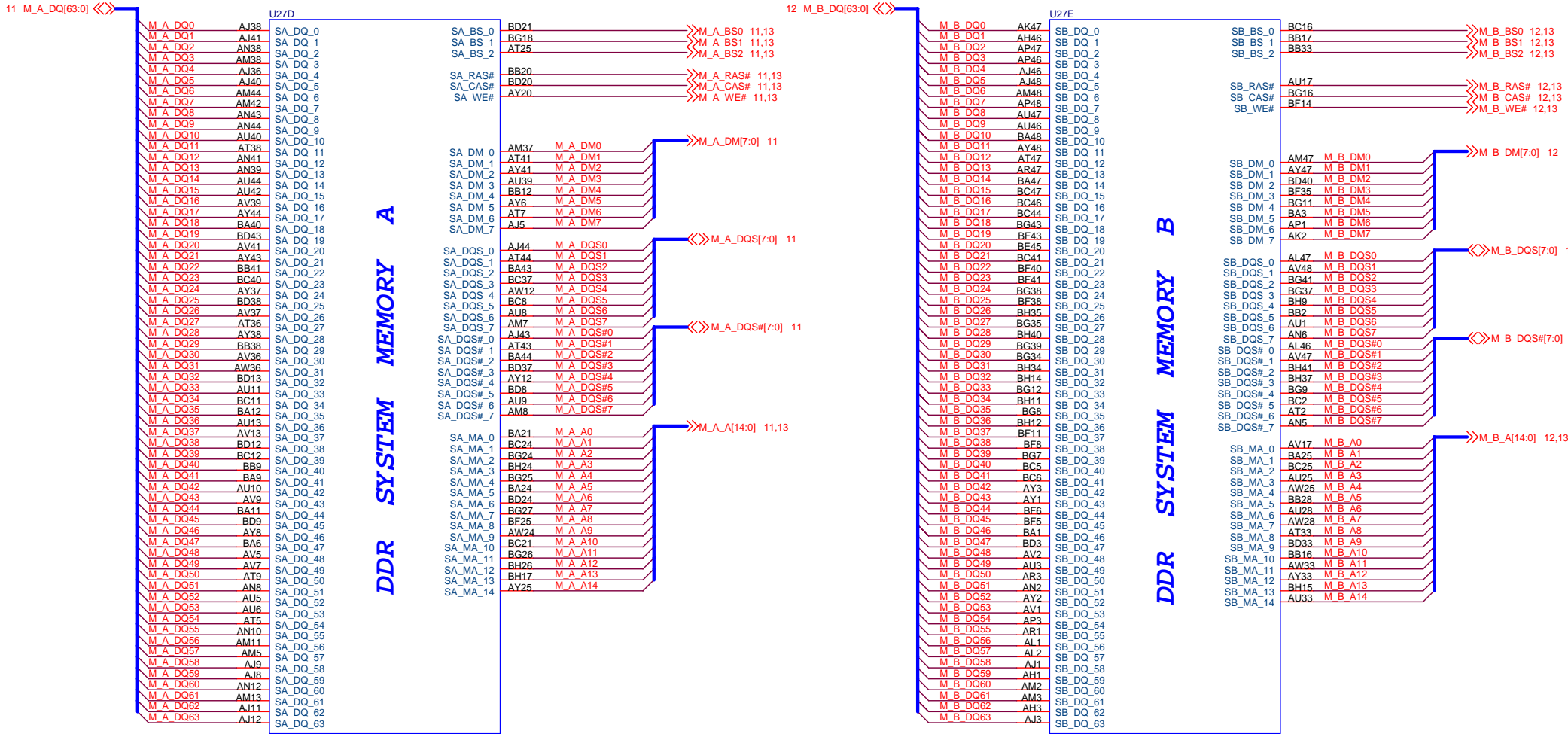

MSI CORPORATION			
Title			
CANTIGA-3 (DDR)			
Size	Document Number	Rev	
Custom	MS-1331	OA	
Date:	Wednesday, August 22, 2007	Sheet	7 of 40

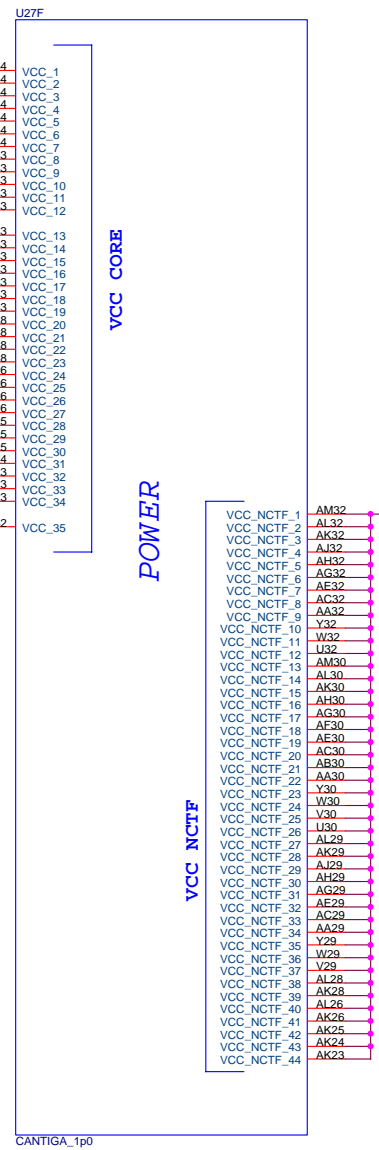
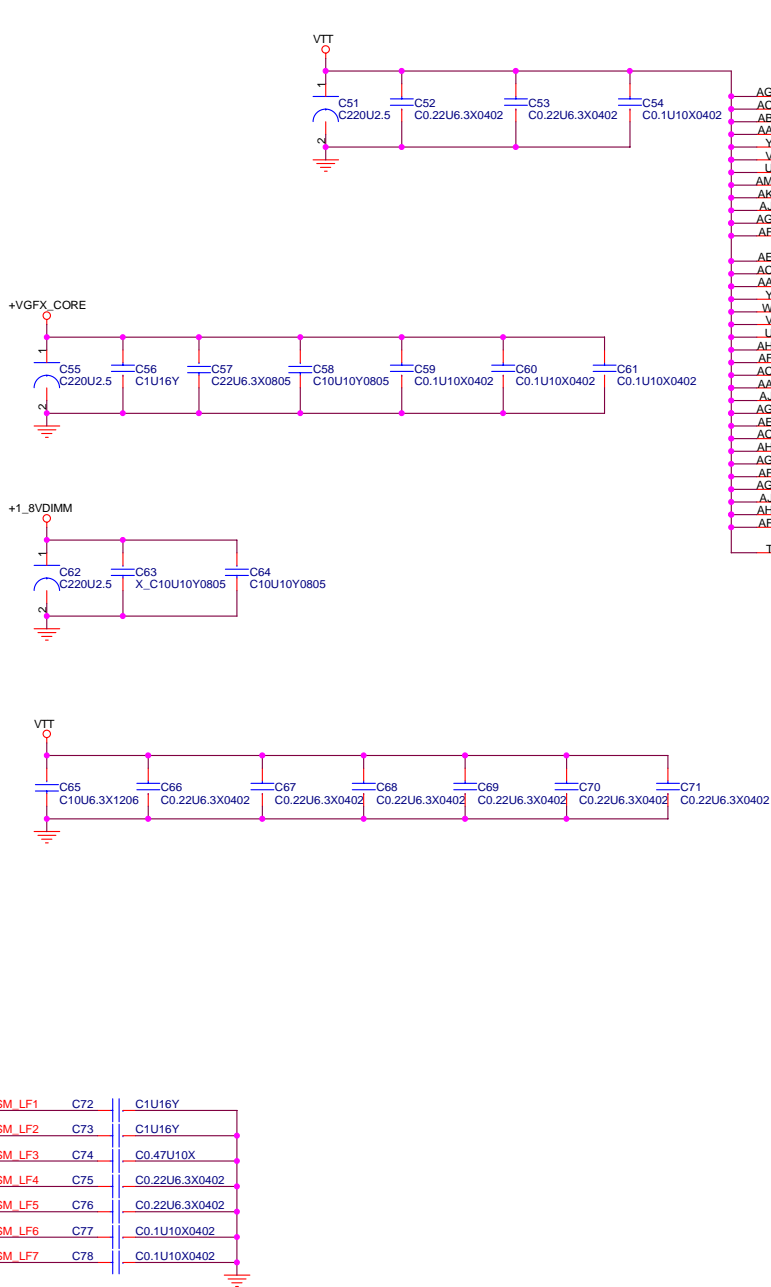
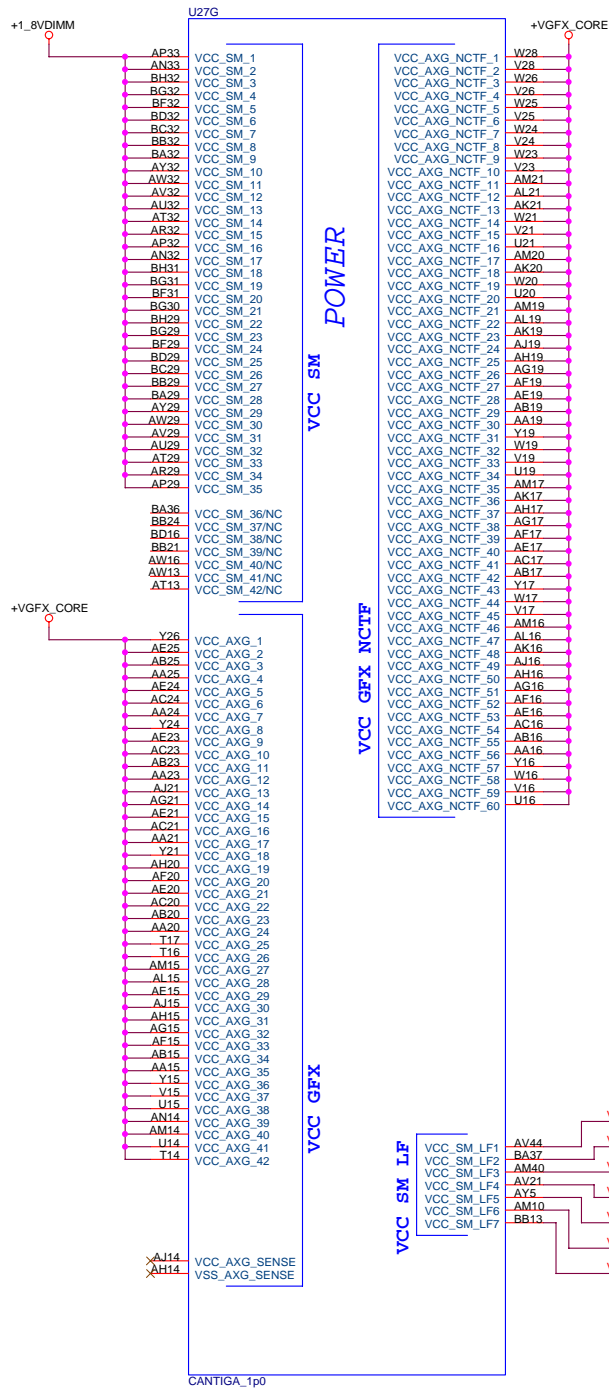

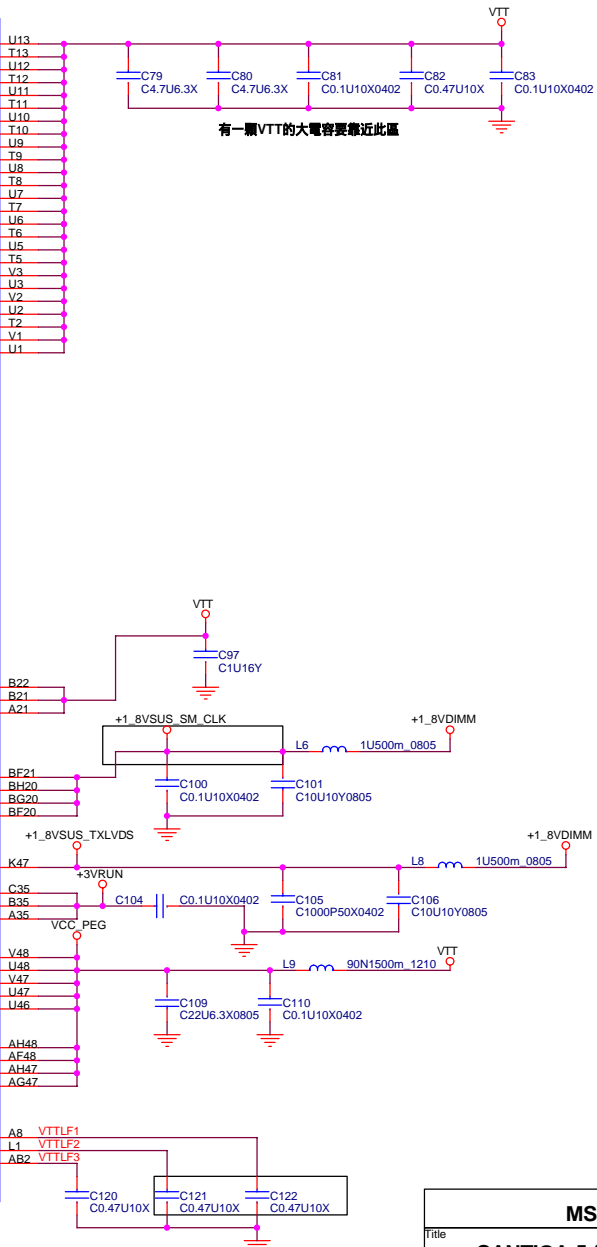
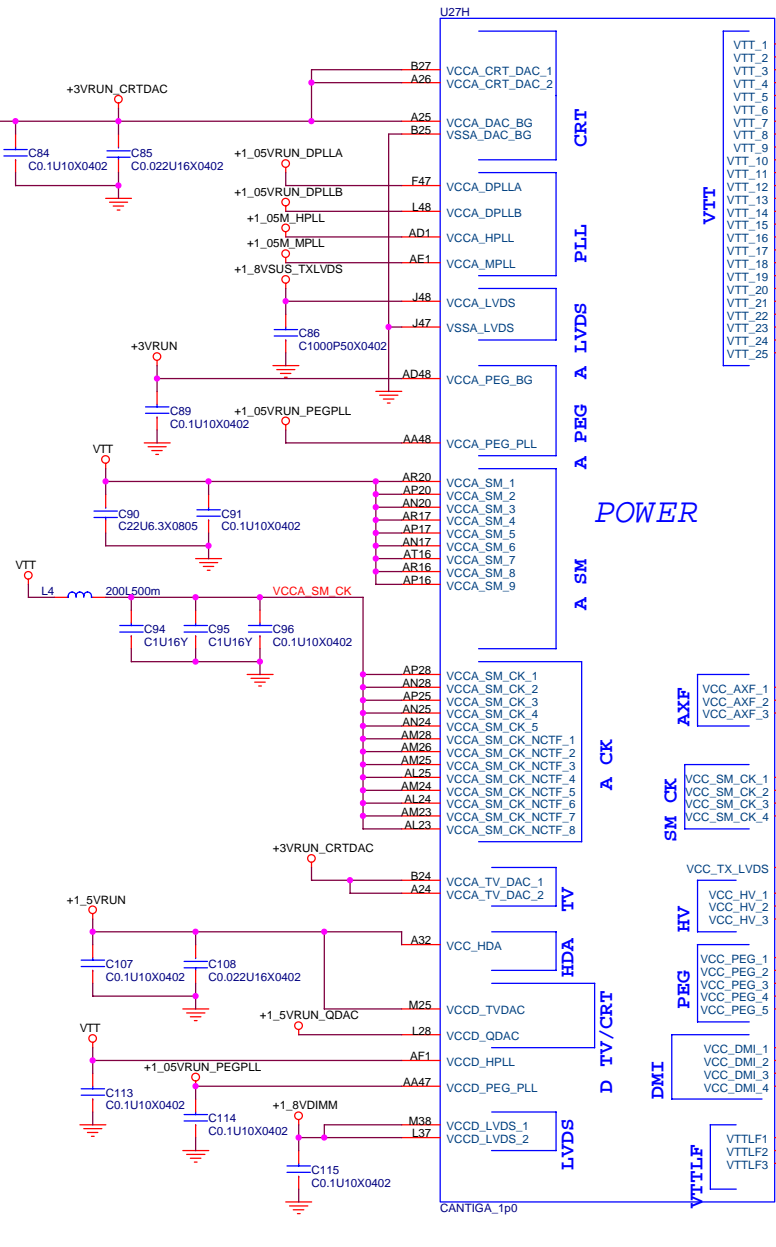
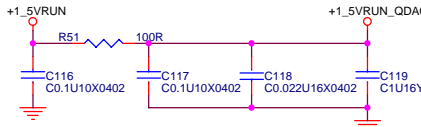
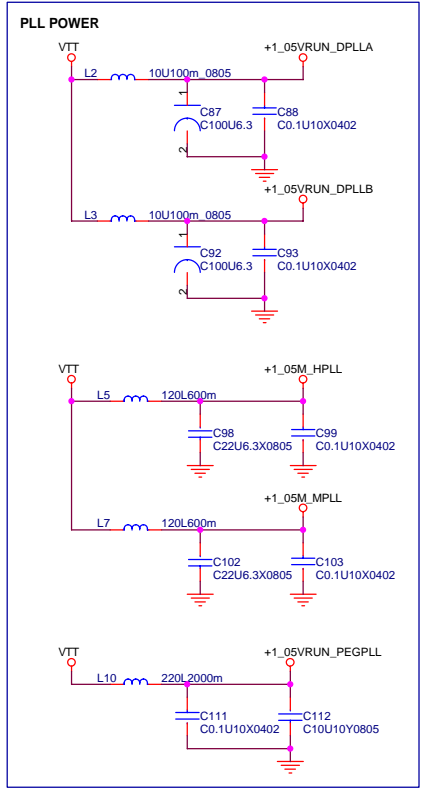

MSI CORPORATION		
Title CANTIGA-5 (POWER-2)		
Size	Document Number	Rev
Custom	MS-1331	0A
Date:	Wednesday, August 22, 2007	Sheet 9 of 40

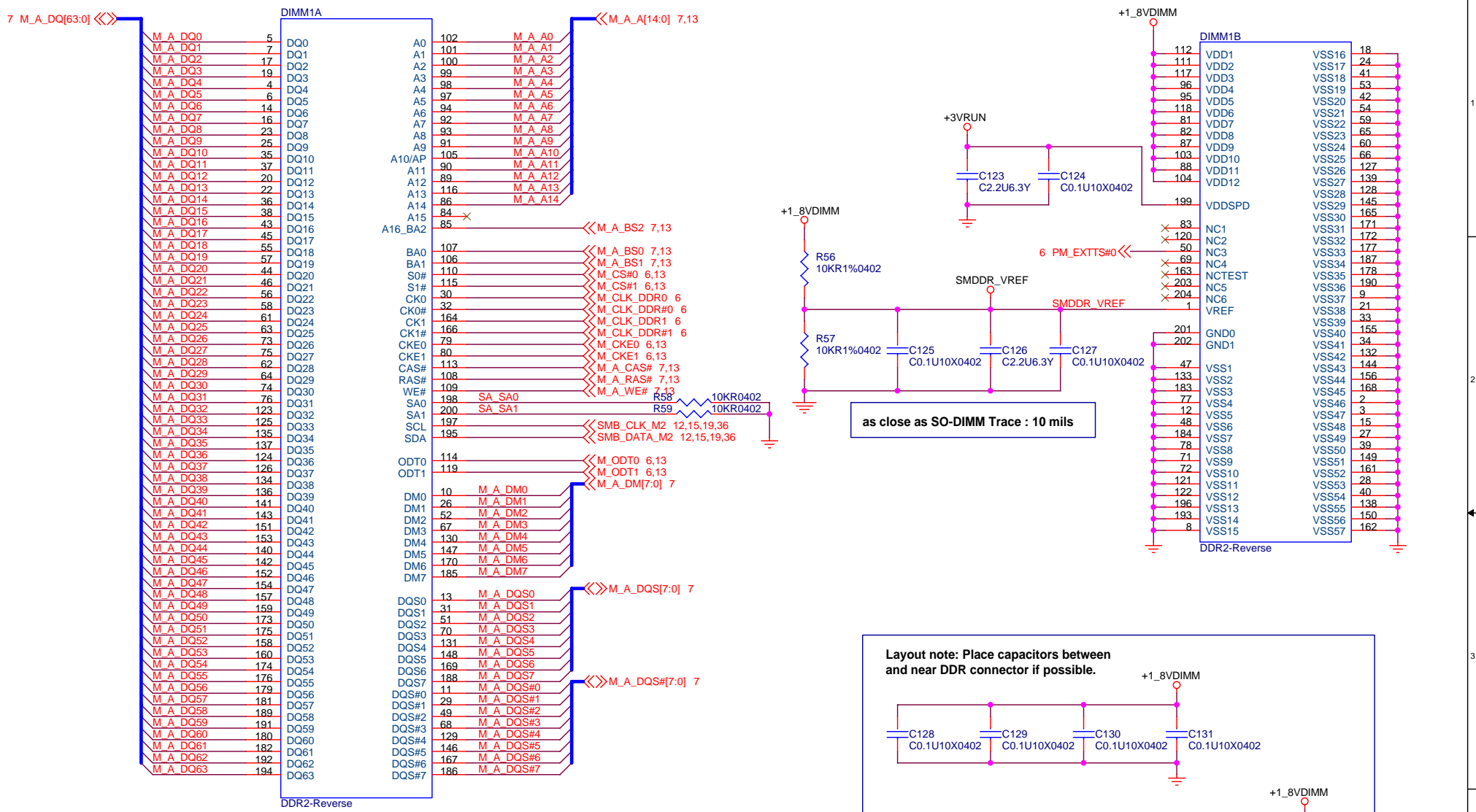

as close as SO-DIMM Trace : 10 mils

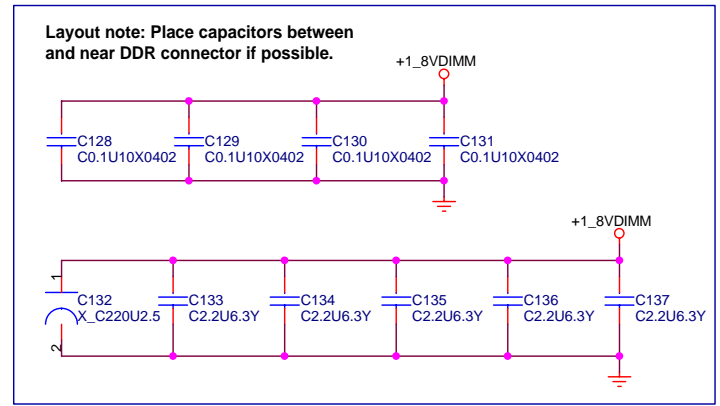

MSI CORPORATION

Title: **DDR2 SODIMM 0**

Size	Document Number	Rev
Custom	MS-1331	0A

Date: Wednesday, August 22, 2007 Sheet 11 of 40

7 M_B_DQ[63:0] <<>

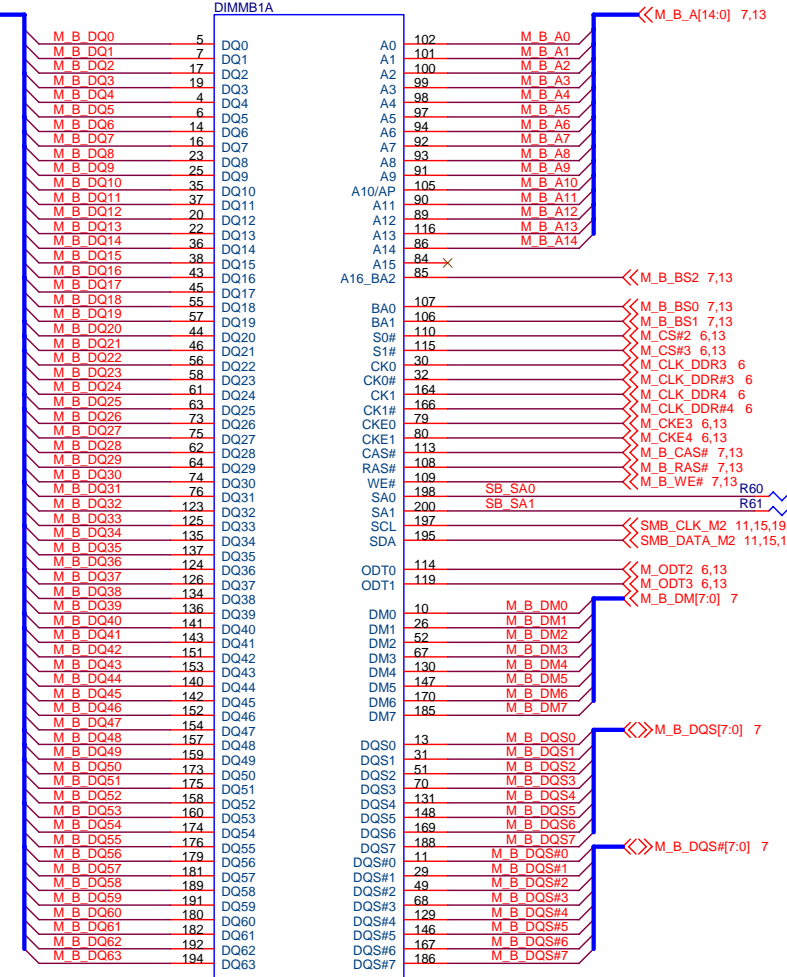

<<M_B_A[14:0] 7,13

<<M_B_BS2 7,13

<<M_B_BS0 7,13

<<M_B_BS1 7,13

<<M_CS#2 6,13

<<M_CS#1 6,13

<<M_CLK_DDR#3 6

<<M_CLK_DDR#4 6

<<M_CKE#3 6,13

<<M_CKE#4 6,13

<<M_B_CAS# 7,13

<<M_B_RAS# 7,13

<<M_B_WE# 7,13

<<SMB_CLK_M2 11,15,19,36

<<SMB_DATA_M2 11,15,19,36

<<M_ODT2 6,13

<<M_ODT3 6,13

<<M_B_DM[7:0] 7

<<M_B_DQS[7:0] 7

<<M_B_DQS#[7:0] 7

DDR2-Reverse_H

+1_8VDIMM

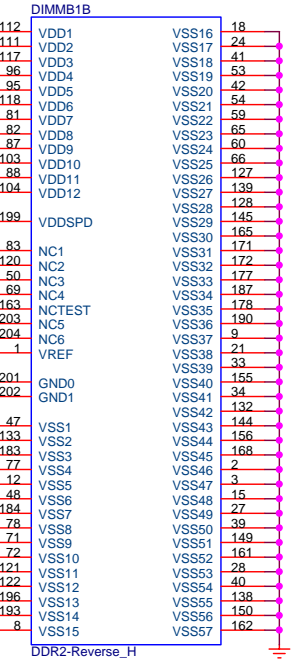

+3VRUN

SMDDR_VREF

+3VRUN

as close as SO-DIMM Trace : 10 mils

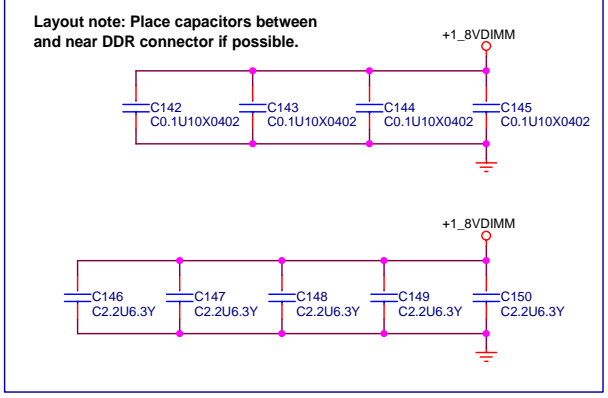

MSI CORPORATION			
Title			
DDR2 SODIMM 1			
Size	Document Number	Rev	
Custom	MS-1331	0A	
Date:	Wednesday, August 22, 2007	Sheet	12 of 40

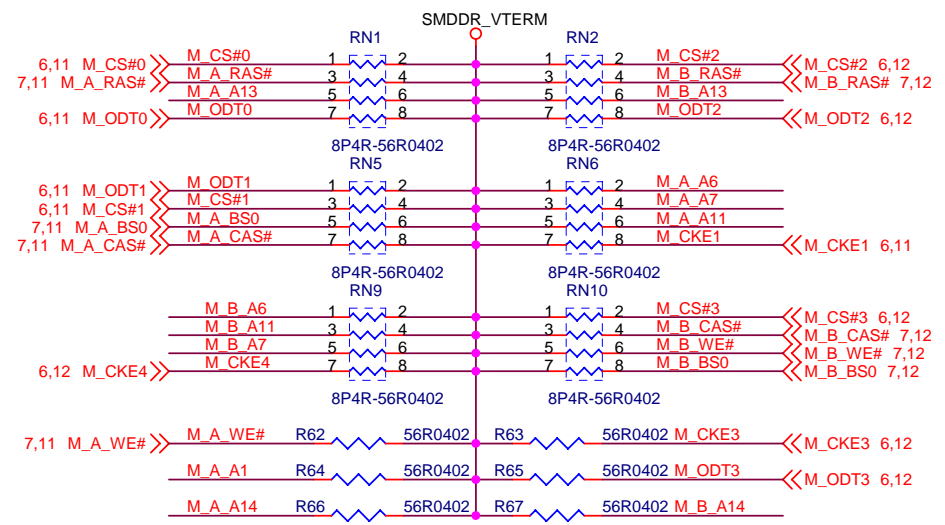
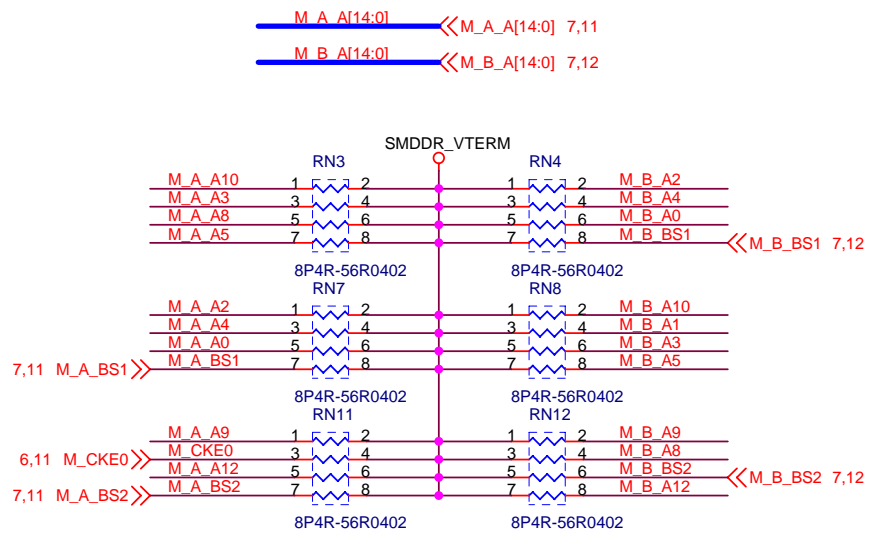

Layout note: Place one cap close to every 2 pullup resistors terminated to +SMDDR_VTERM.

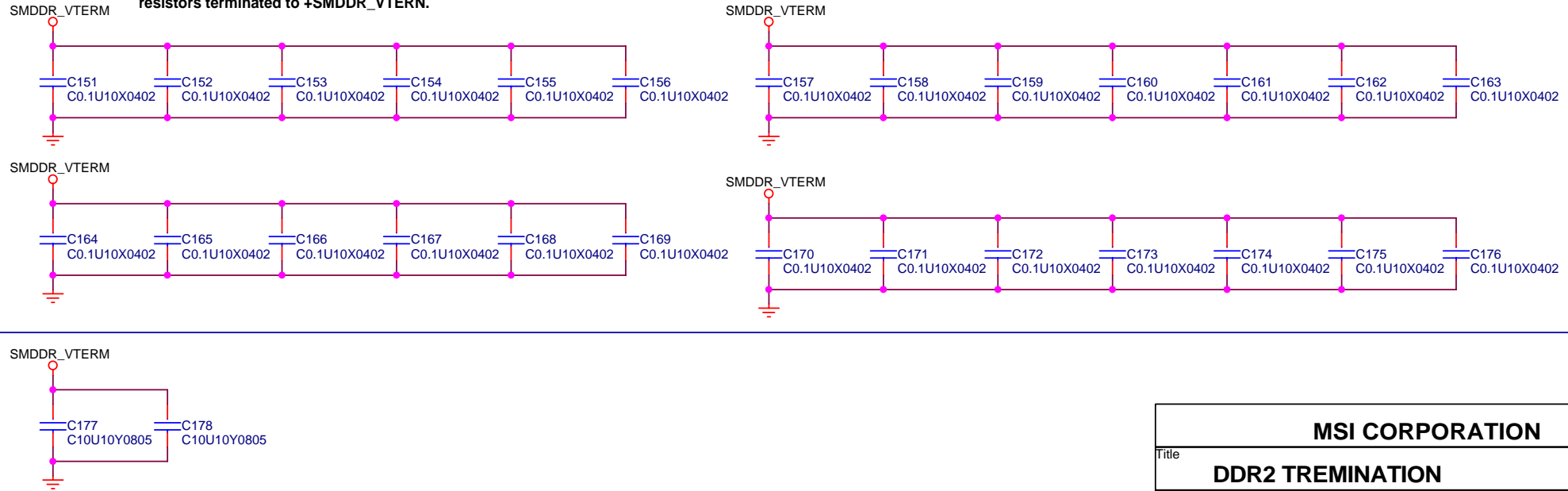

MSI CORPORATION		
DDR2 TREMINATION		
Title		
Size	Document Number	Rev
Custom	MS-1331	0A
Date:	Wednesday, August 22, 2007	Sheet 13 of 40

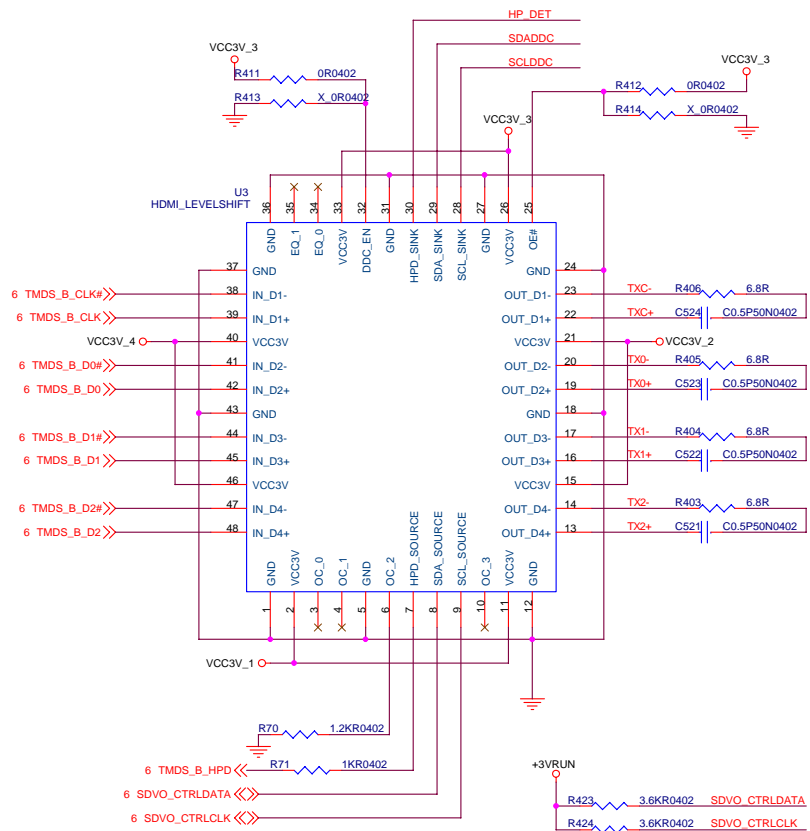
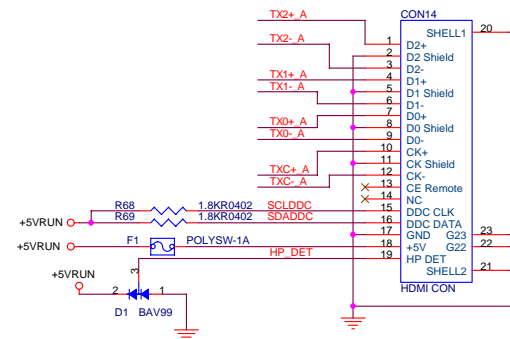
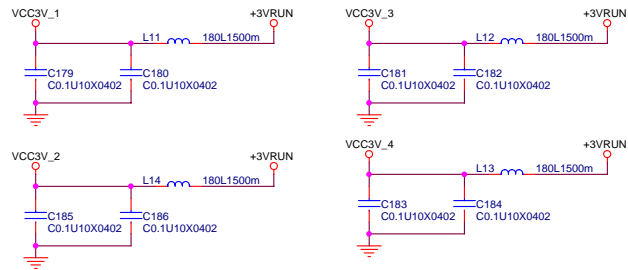

CLOSE TO CONNECTOR

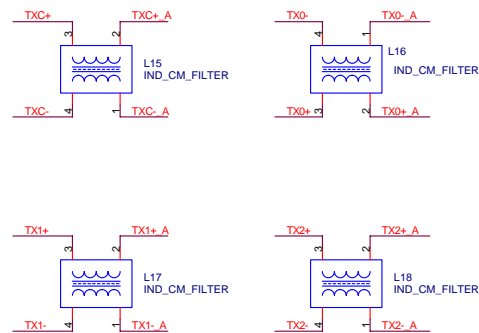

MSI CORPORATION		
Title: HDMI-LEVELSHIFT		
Size: Custom	Document Number: MS-1331	Rev: 0A
Date: Wednesday, August 22, 2007	Sheet: 14	of 40

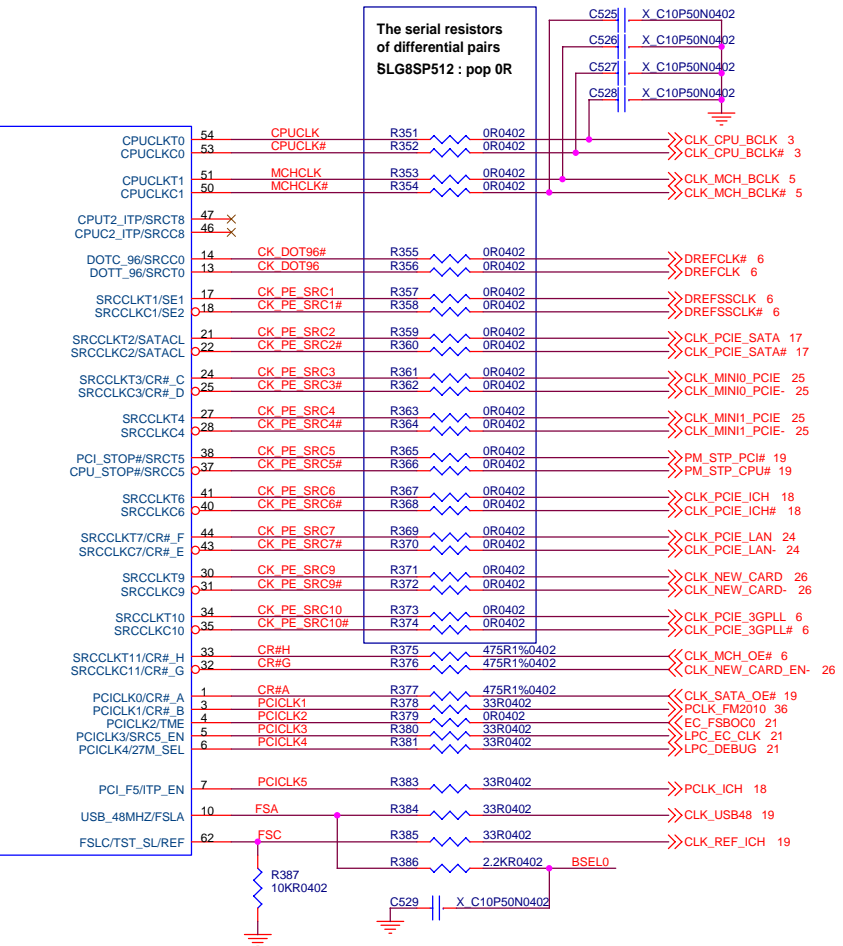
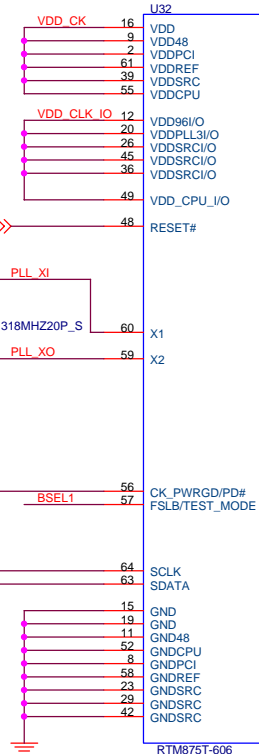
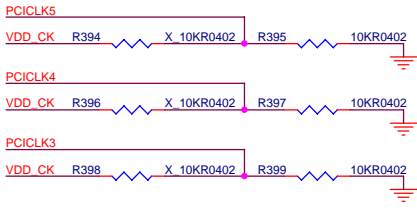
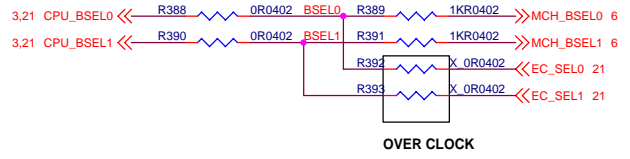
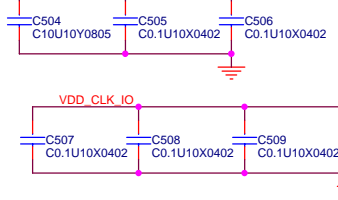
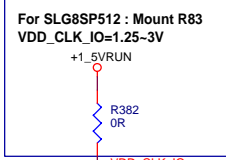
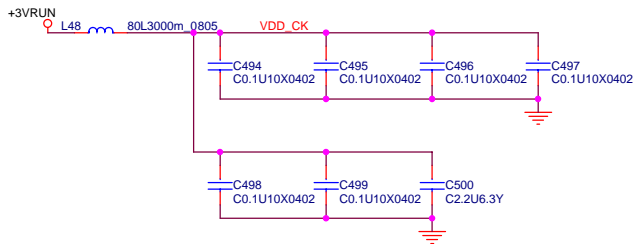

PIN#	DESCRIPTION	USAGE
1	Control SRC2 pair	CR#_A
32	Control SRC9 pair	CR#_G
33	Control SRC10 pair	CR#_H

FSC Bit7	FSB Bit6	FSA Bit5	CPU MHz
0	0	0	266.66
0	0	1	133.33
0	1	0	200.00
0	1	1	166.66
1	0	0	333.33
1	0	1	100.00
1	1	0	400.00

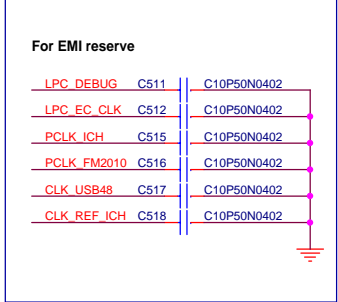

MSI CORPORATION

Title: **CLOCK Generator (ICS9LPR906)**

Size: A3 Document Number: **MS-1331** Rev: 0A

Date: Wednesday, August 22, 2007 Sheet: 15 of 40

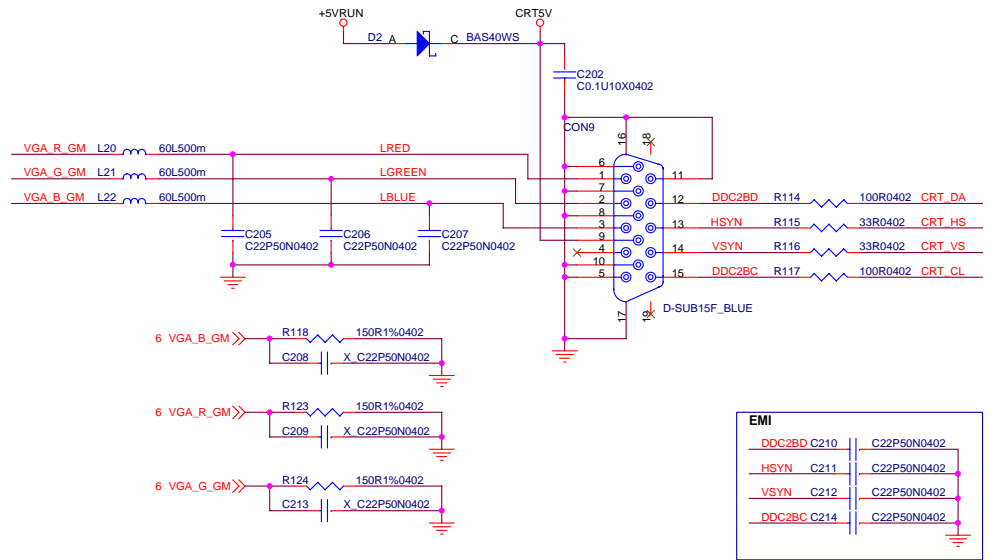
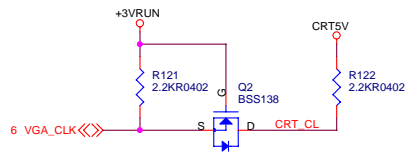
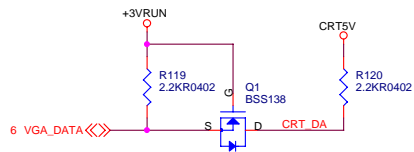
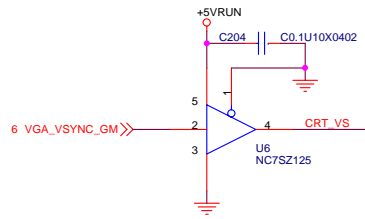
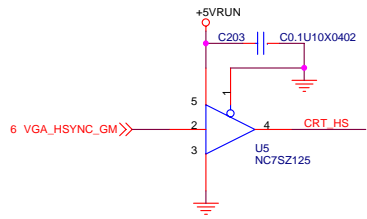

EMI

DDC2BD C210	C22P50N0402
HSYN C211	C22P50N0402
VSYN C212	C22P50N0402
DDC2BC C214	C22P50N0402

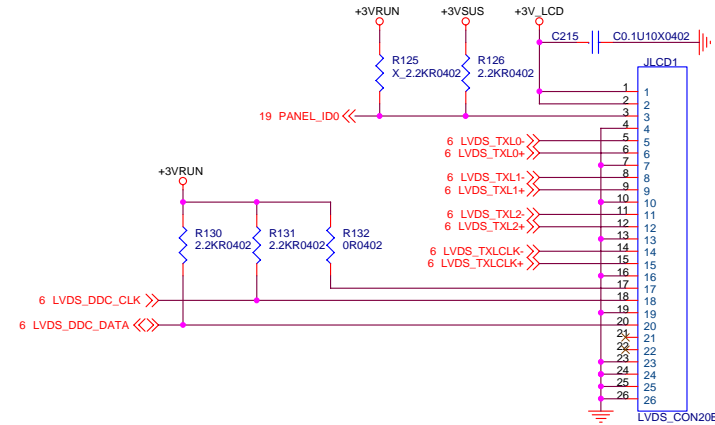
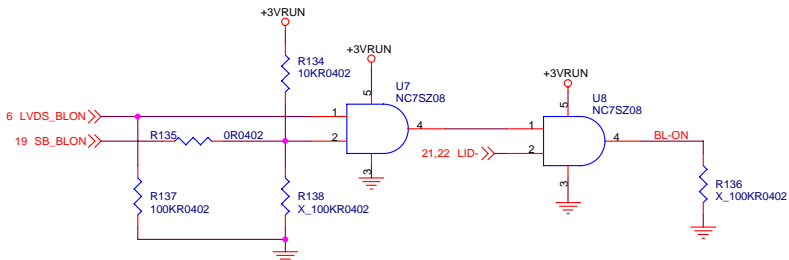
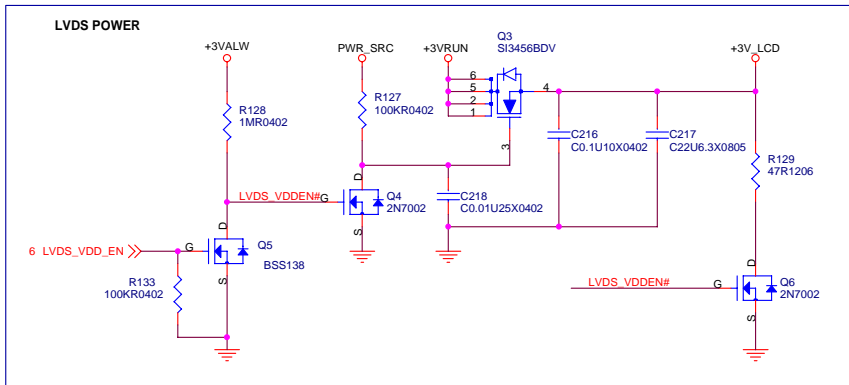

CABLE PIN DEFINE

LVDS CABLE	JLCD1
1	===== GND
2	===== 1
3	===== 2
4	===== 17
5	===== NC
6	===== 18
7	===== 20
8	===== 5
9	===== 6
10	===== 8
11	===== 9
12	===== GND
13	===== 11
14	===== 12
15	===== 14
16	===== 15
17	===== GND
18	===== 14
19	===== 15
20	===== GND

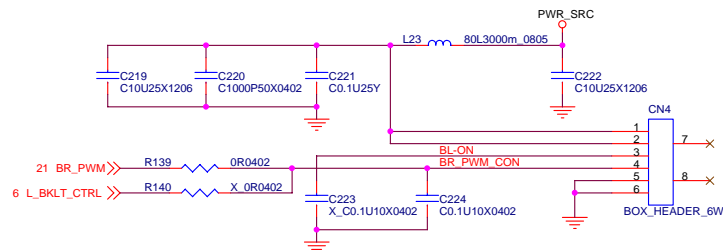

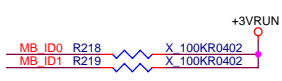
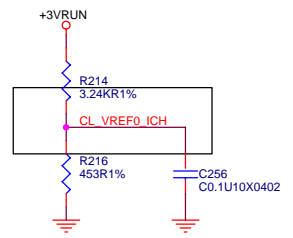
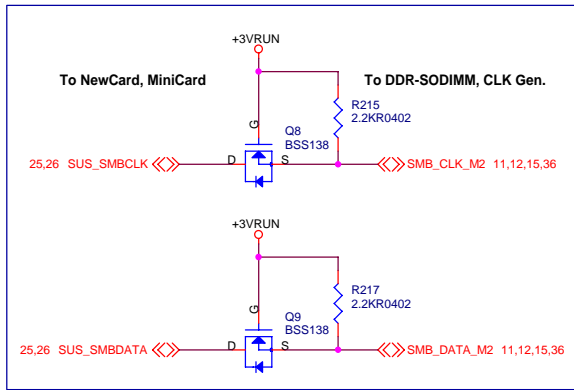
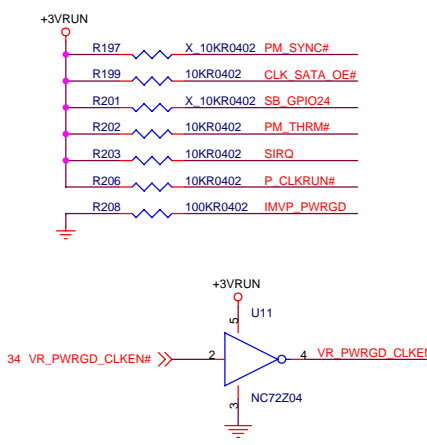
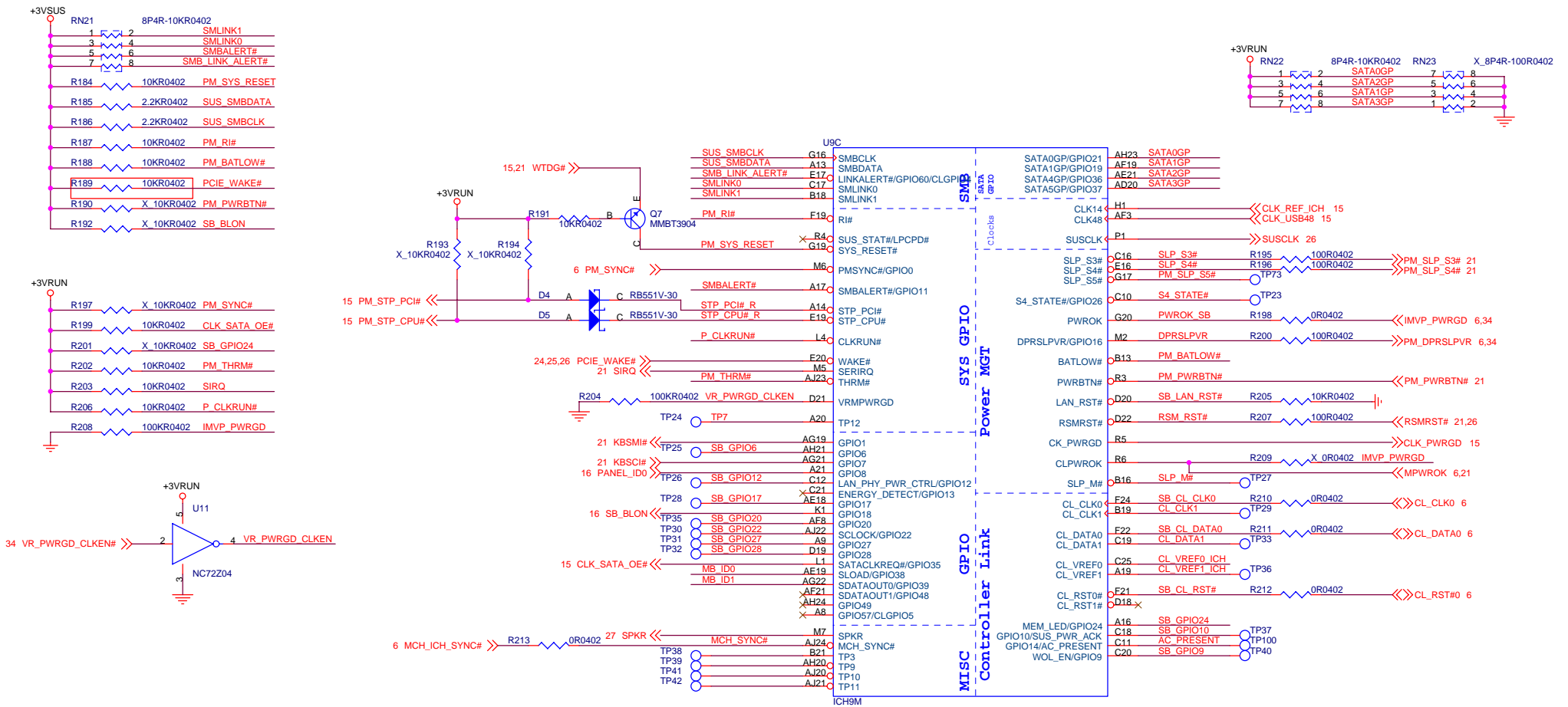

MSI CORPORATION		
Title		
ICH9M-3 (SM BUS/GPIO)		
Size	Document Number	Rev
A3	MS-1331	0A
Date:	Wednesday, August 22, 2007	Sheet 19 of 40

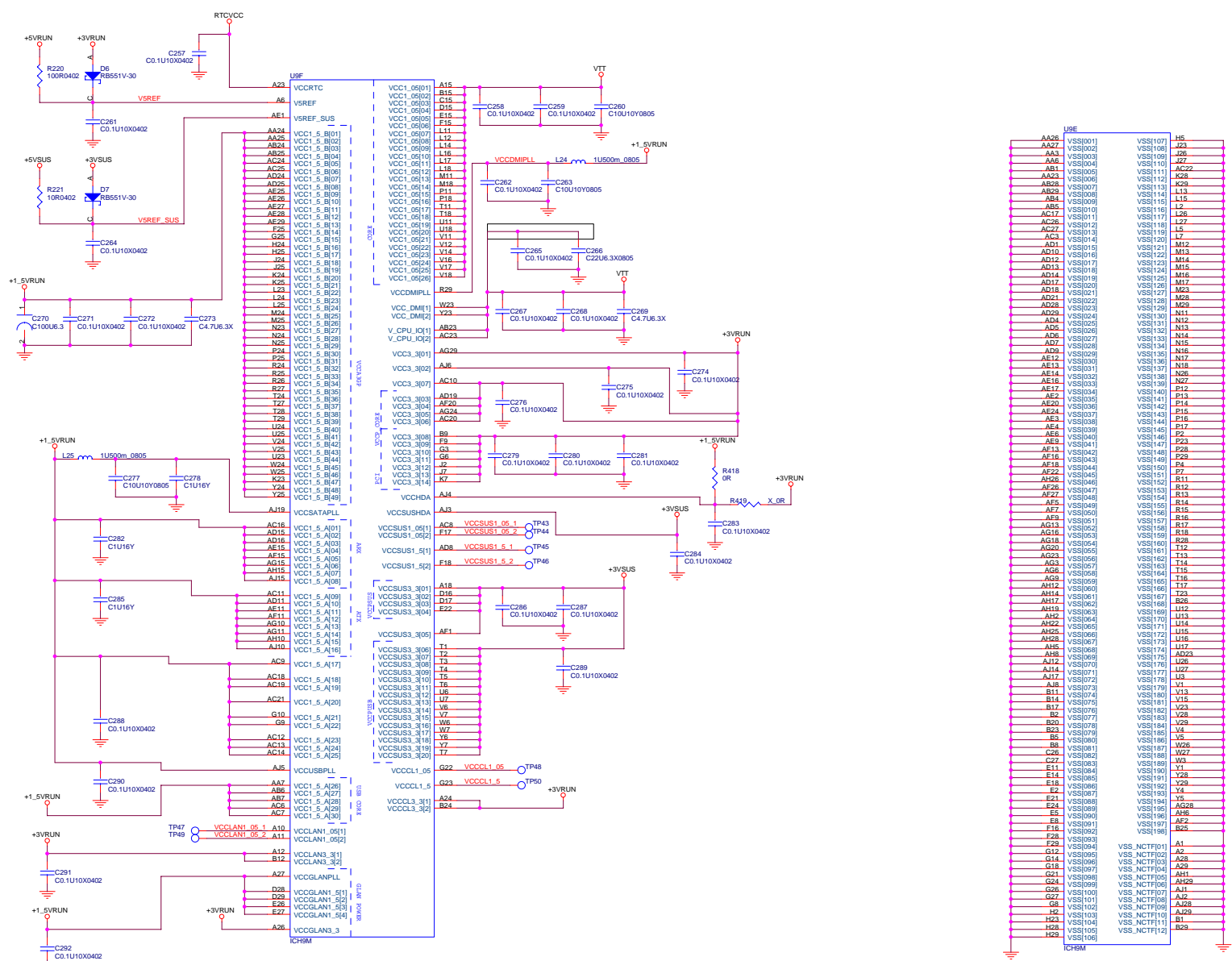

Pin	Processor Pin	Processor Pin
AA26	VSS1001	VSS107
AA27	VSS1002	VSS108
AA28	VSS1003	VSS109
AA29	VSS1004	VSS110
AA30	VSS1005	VSS111
AA31	VSS1006	VSS112
AA32	VSS1007	VSS113
AA33	VSS1008	VSS114
AA34	VSS1009	VSS115
AA35	VSS1010	VSS116
AA36	VSS1011	VSS117
AA37	VSS1012	VSS118
AA38	VSS1013	VSS119
AA39	VSS1014	VSS120
AA40	VSS1015	VSS121
AA41	VSS1016	VSS122
AA42	VSS1017	VSS123
AA43	VSS1018	VSS124
AA44	VSS1019	VSS125
AA45	VSS1020	VSS126
AA46	VSS1021	VSS127
AA47	VSS1022	VSS128
AA48	VSS1023	VSS129
AA49	VSS1024	VSS130
AA50	VSS1025	VSS131
AA51	VSS1026	VSS132
AA52	VSS1027	VSS133
AA53	VSS1028	VSS134
AA54	VSS1029	VSS135
AA55	VSS1030	VSS136
AA56	VSS1031	VSS137
AA57	VSS1032	VSS138
AA58	VSS1033	VSS139
AA59	VSS1034	VSS140
AA60	VSS1035	VSS141
AA61	VSS1036	VSS142
AA62	VSS1037	VSS143
AA63	VSS1038	VSS144
AA64	VSS1039	VSS145
AA65	VSS1040	VSS146
AA66	VSS1041	VSS147
AA67	VSS1042	VSS148
AA68	VSS1043	VSS149
AA69	VSS1044	VSS150
AA70	VSS1045	VSS151
AA71	VSS1046	VSS152
AA72	VSS1047	VSS153
AA73	VSS1048	VSS154
AA74	VSS1049	VSS155
AA75	VSS1050	VSS156
AA76	VSS1051	VSS157
AA77	VSS1052	VSS158
AA78	VSS1053	VSS159
AA79	VSS1054	VSS160
AA80	VSS1055	VSS161
AA81	VSS1056	VSS162
AA82	VSS1057	VSS163
AA83	VSS1058	VSS164
AA84	VSS1059	VSS165
AA85	VSS1060	VSS166
AA86	VSS1061	VSS167
AA87	VSS1062	VSS168
AA88	VSS1063	VSS169
AA89	VSS1064	VSS170
AA90	VSS1065	VSS171
AA91	VSS1066	VSS172
AA92	VSS1067	VSS173
AA93	VSS1068	VSS174
AA94	VSS1069	VSS175
AA95	VSS1070	VSS176
AA96	VSS1071	VSS177
AA97	VSS1072	VSS178
AA98	VSS1073	VSS179
AA99	VSS1074	VSS180
AA100	VSS1075	VSS181
AA101	VSS1076	VSS182
AA102	VSS1077	VSS183
AA103	VSS1078	VSS184
AA104	VSS1079	VSS185
AA105	VSS1080	VSS186
AA106	VSS1081	VSS187
AA107	VSS1082	VSS188
AA108	VSS1083	VSS189
AA109	VSS1084	VSS190
AA110	VSS1085	VSS191
AA111	VSS1086	VSS192
AA112	VSS1087	VSS193
AA113	VSS1088	VSS194
AA114	VSS1089	VSS195
AA115	VSS1090	VSS196
AA116	VSS1091	VSS197
AA117	VSS1092	VSS198
AA118	VSS1093	VSS199
AA119	VSS1094	VSS200
AA120	VSS1095	VSS_NCTF01
AA121	VSS1096	VSS_NCTF02
AA122	VSS1097	VSS_NCTF03
AA123	VSS1098	VSS_NCTF04
AA124	VSS1099	VSS_NCTF05
AA125	VSS1100	VSS_NCTF06
AA126	VSS1101	VSS_NCTF07
AA127	VSS1102	VSS_NCTF08
AA128	VSS1103	VSS_NCTF09
AA129	VSS1104	VSS_NCTF10
AA130	VSS1105	VSS_NCTF11
AA131	VSS1106	VSS_NCTF12

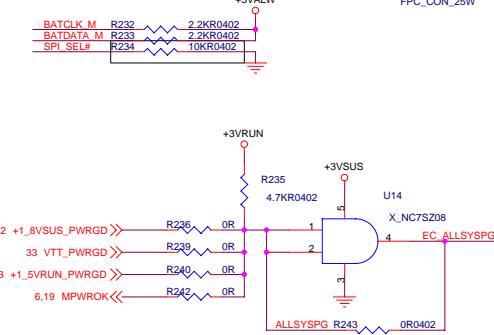
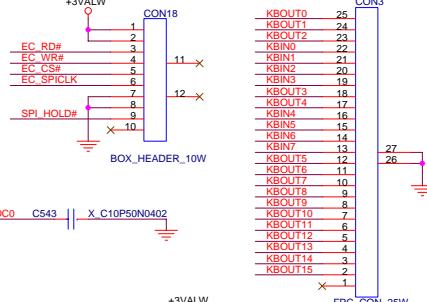
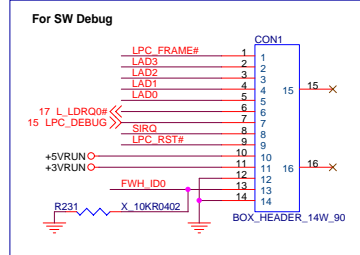
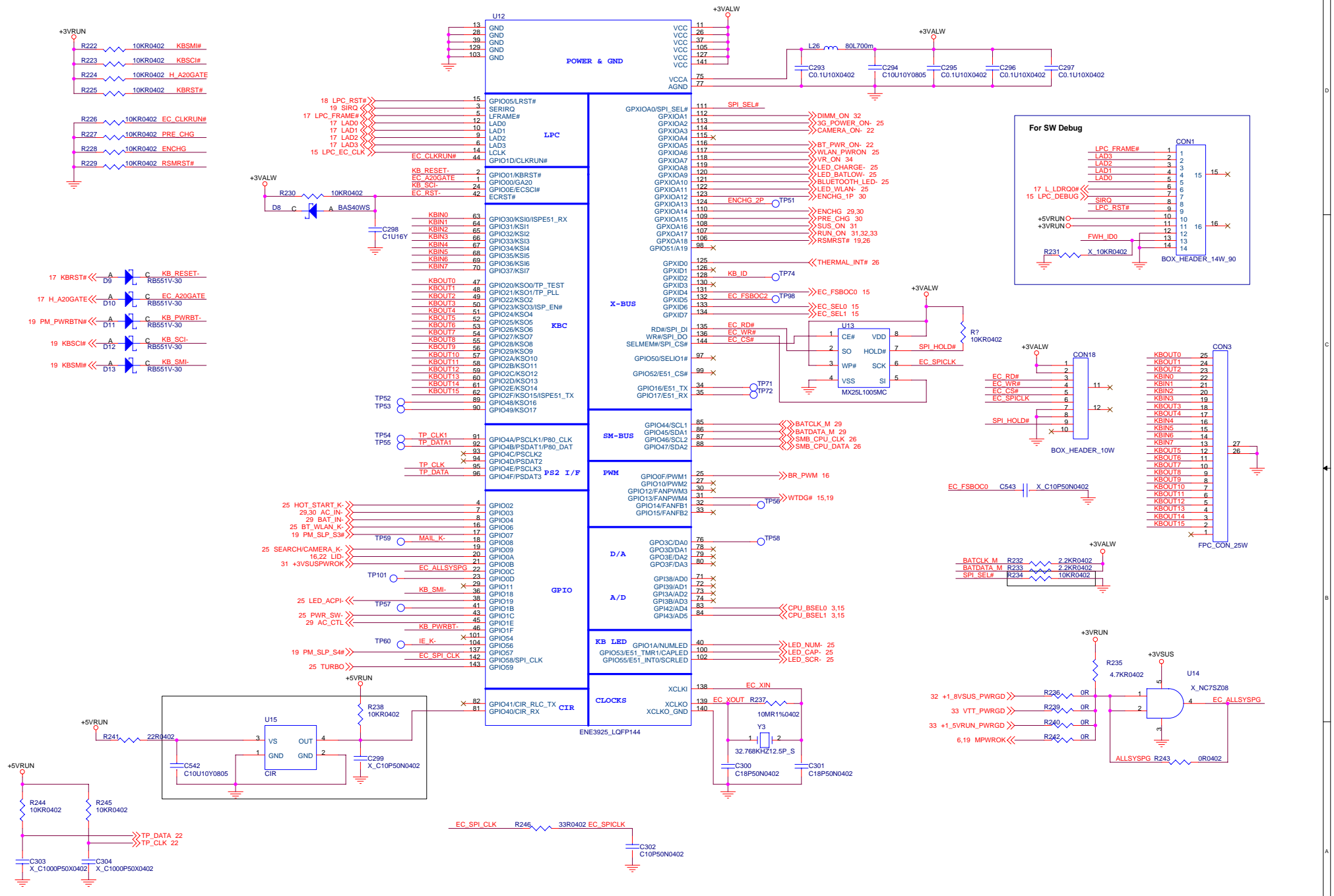

SATA HDD

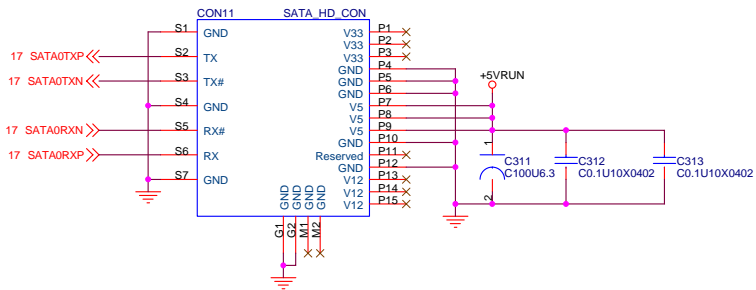

FINGERPRINT & TOUCH PAD

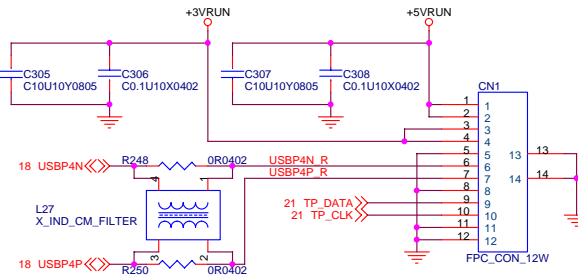

CAMERA

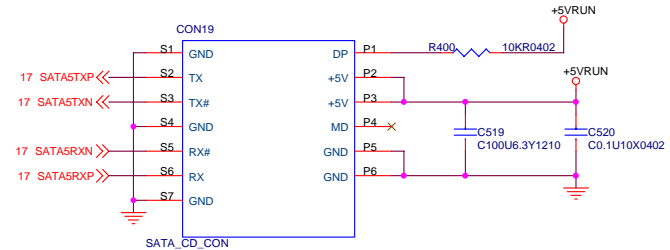
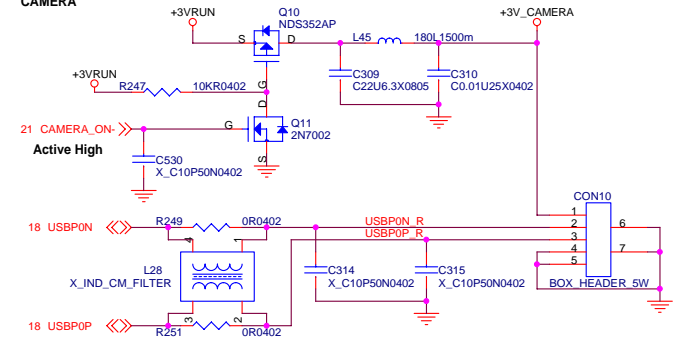

LEFT USB

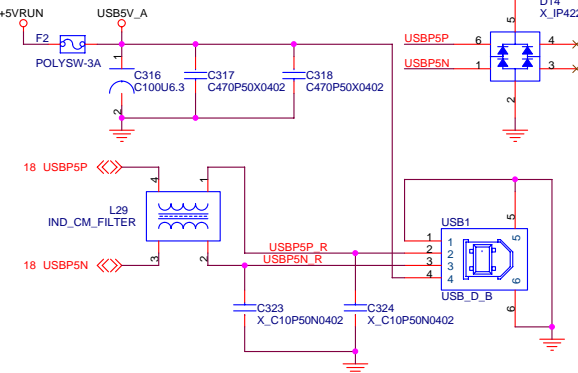

RIGHT USB

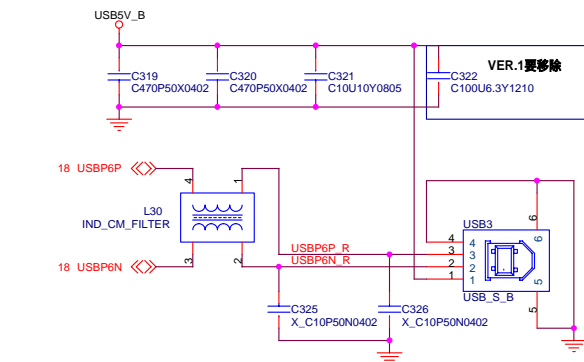

BLUETOOTH

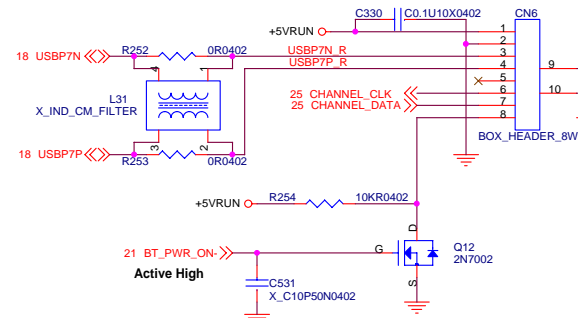

LID

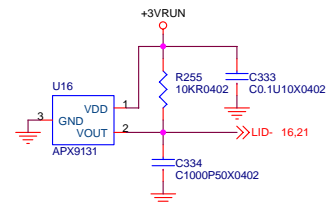

MSI CORPORATION		
Title HDD,CDROM,LID,USB		
Size	Document Number	Rev
Custom	MS-1331	0A
Date:	Wednesday, August 22, 2007	Sheet 22 of 40

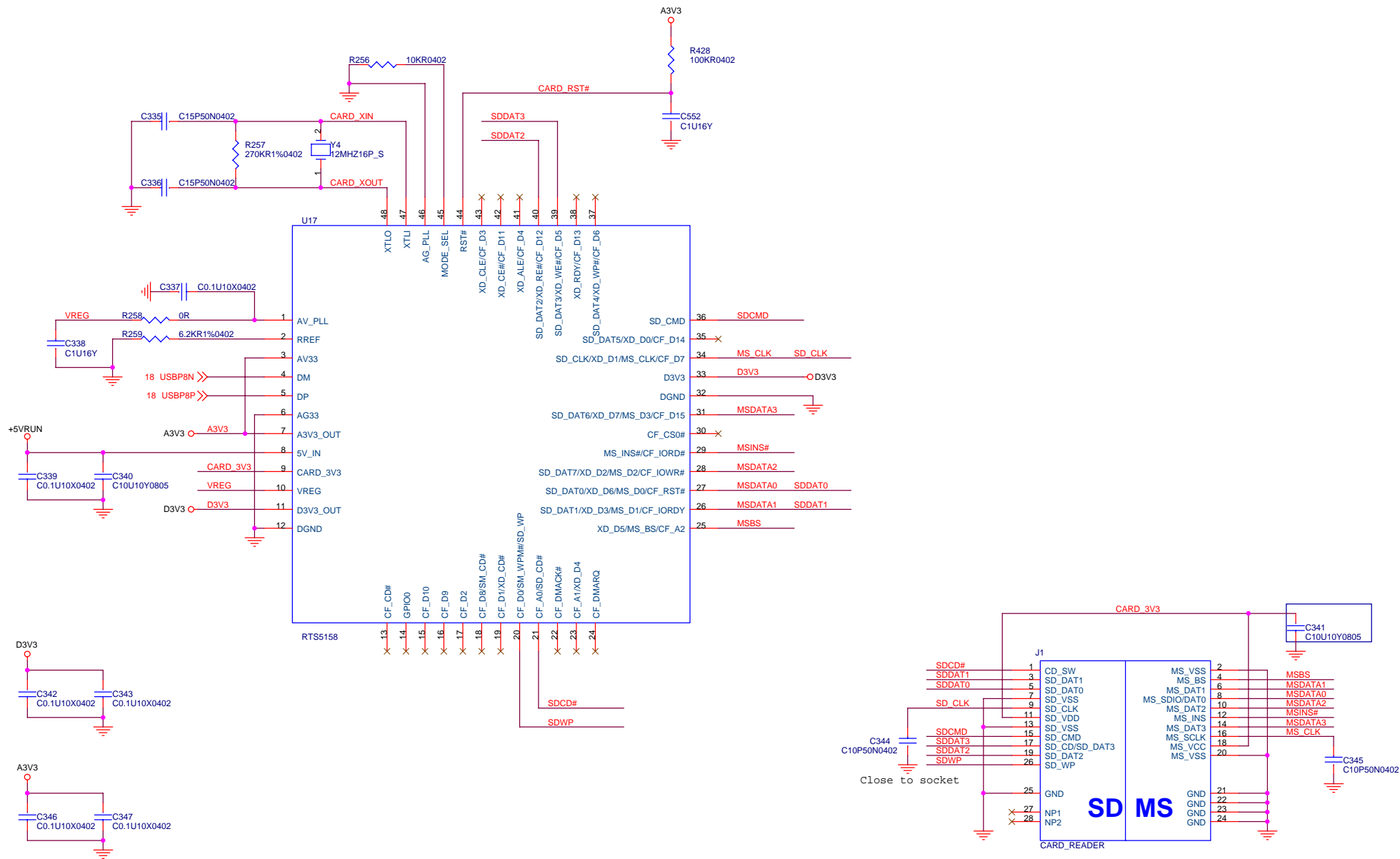

MSI CORPORATION		
Title		
Card Reader (RTS5158)		
Size	Document Number	Rev
A3	MS-1331	0A
Date:	Wednesday, August 22, 2007	Sheet 23 of 40

NEW CARD

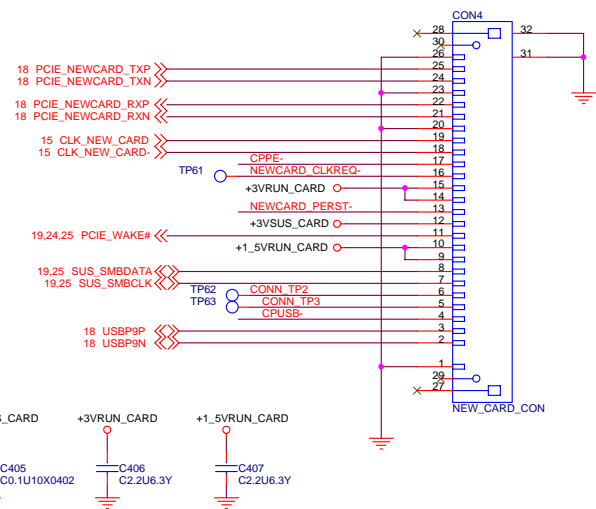
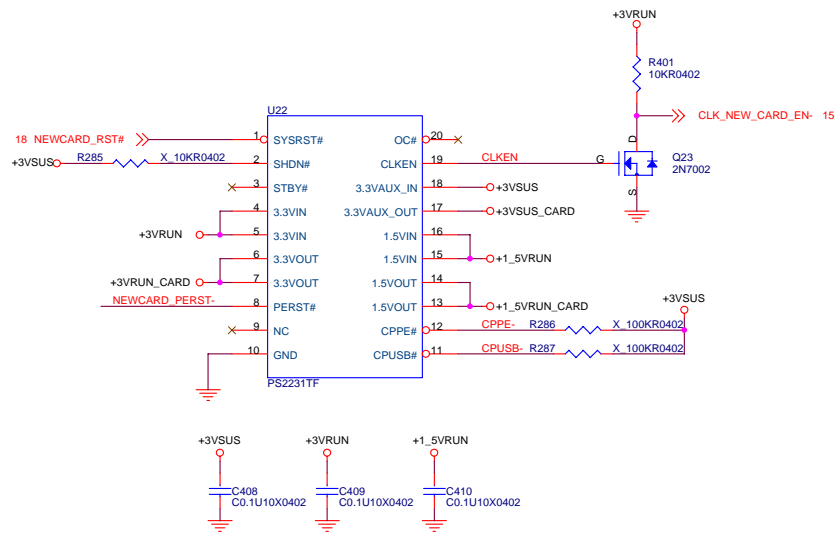

MDC Connector

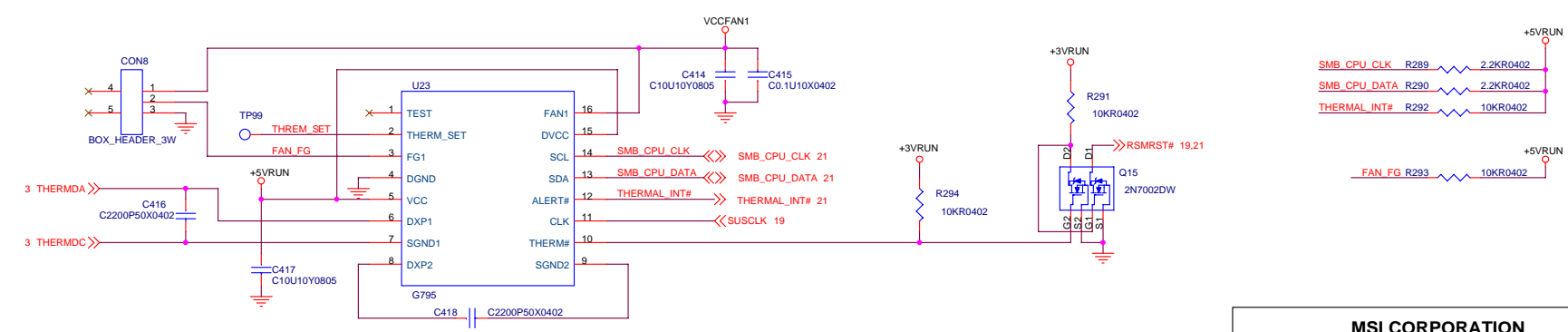
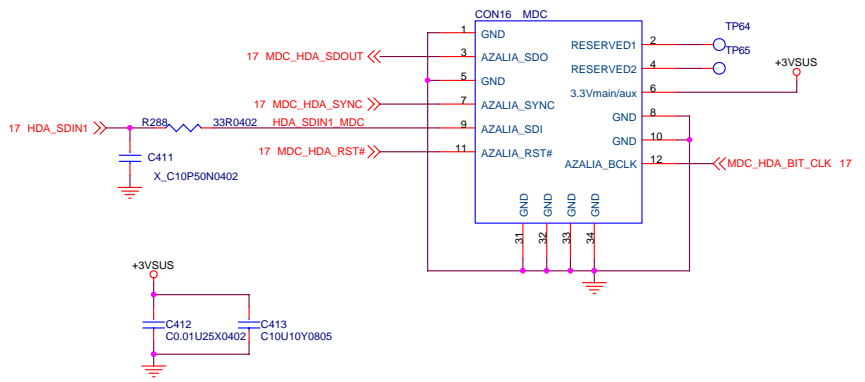

MSI CORPORATION		
NEWCARD, MDC, TPM, FAN		
Title	Document Number	Rev
Size	Custom	0A
MS-1331		
Date	Wednesday, August 22, 2007	Sheet 26 of 40

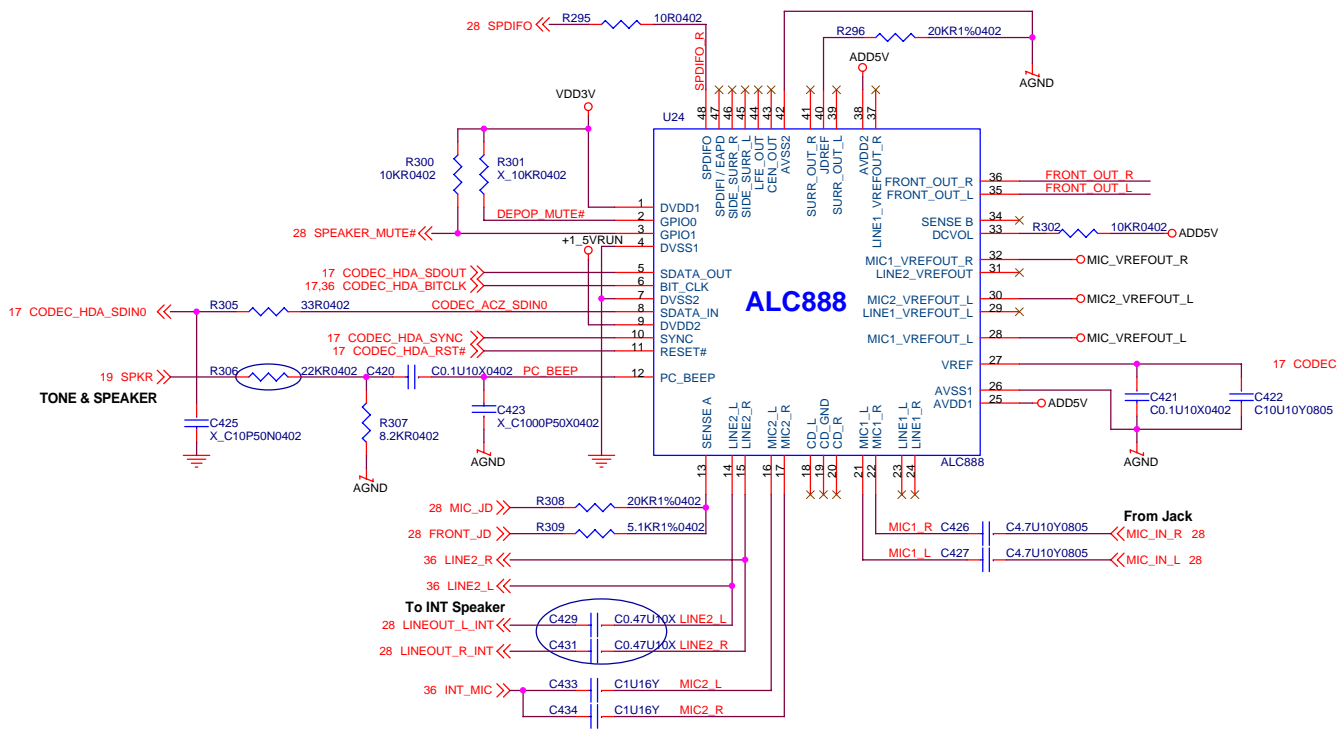

POWER ON/OFF/S3/S4 NOISE CONTROL

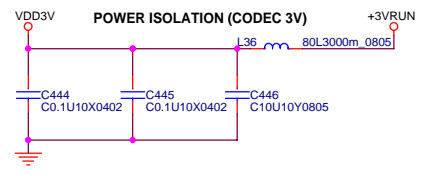
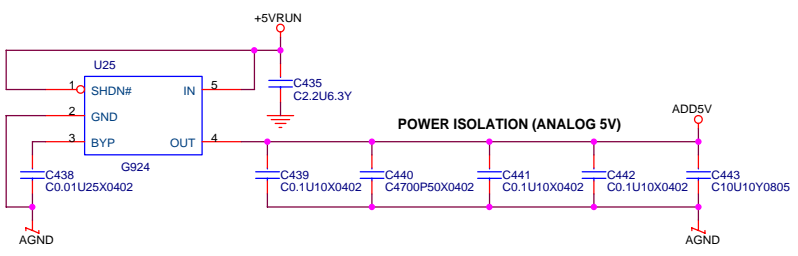
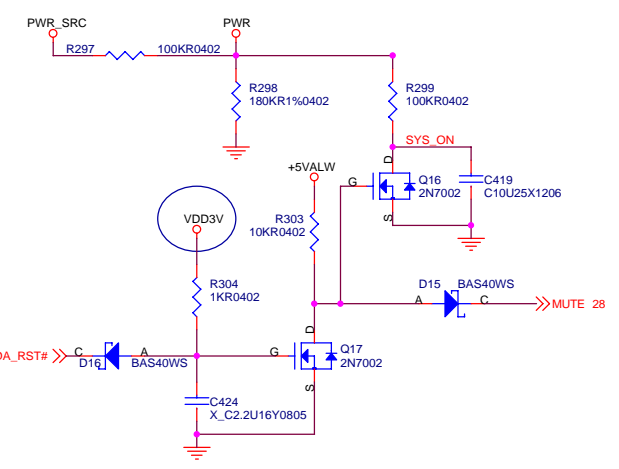

D-S interchange

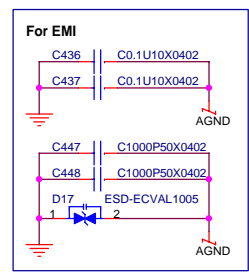
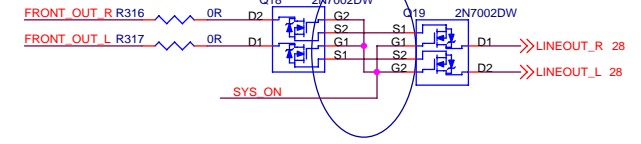

MSI CORPORATION		
Title	AZALIA CODEC(ALC888)	
Size	Document Number	Rev
Custom	MS-1331	0A
Date:	Wednesday, August 22, 2007	Sheet 27 of 40

Internal Speaker Circuit

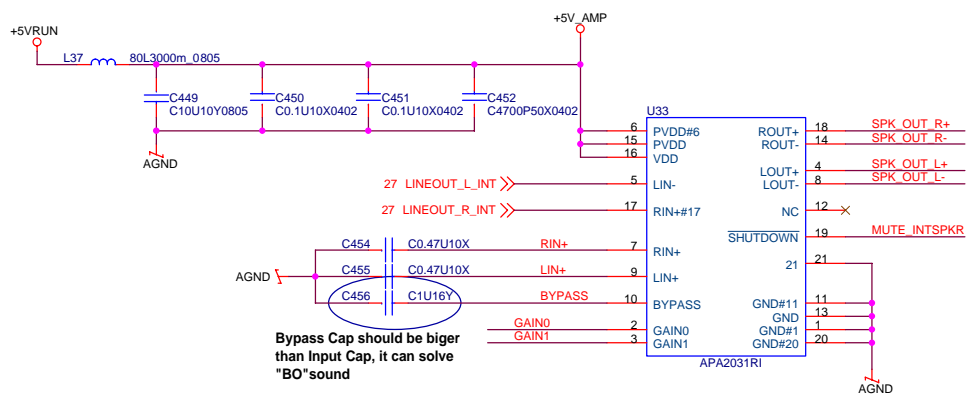

(MUTE SPEAKER)

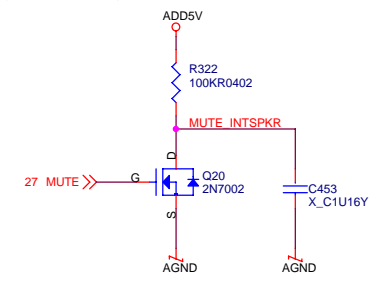

POWER ON/OFF/S3/S4 NOISE CONTROL

FOR APA2031

GAIN0	GAIN1	
6dB	0	0
10dB	0	1
15.6dB	1	0
21.6dB	1	1
4.3dB	X	X

Internal Speaker Connector

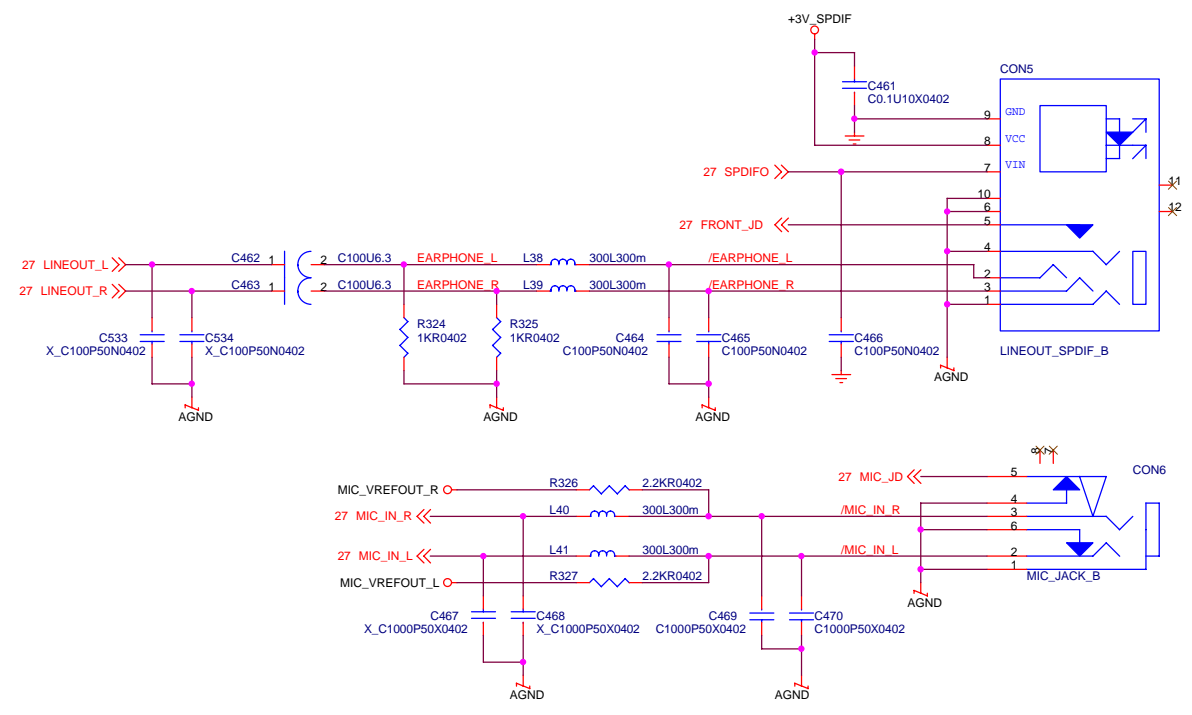
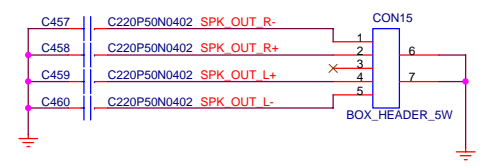

SPDIF ON/OFF CONTROL

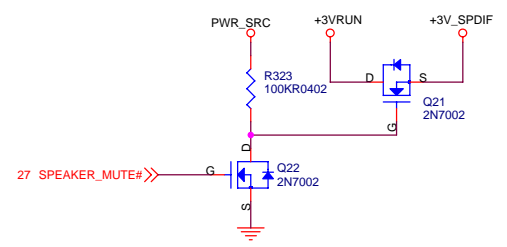

MSI CORPORATION		
Title Audio Amp. & Jacks		
Size A3	Document Number MS-1331	Rev 0A
Date: Wednesday, August 22, 2007	Sheet 28	of 40

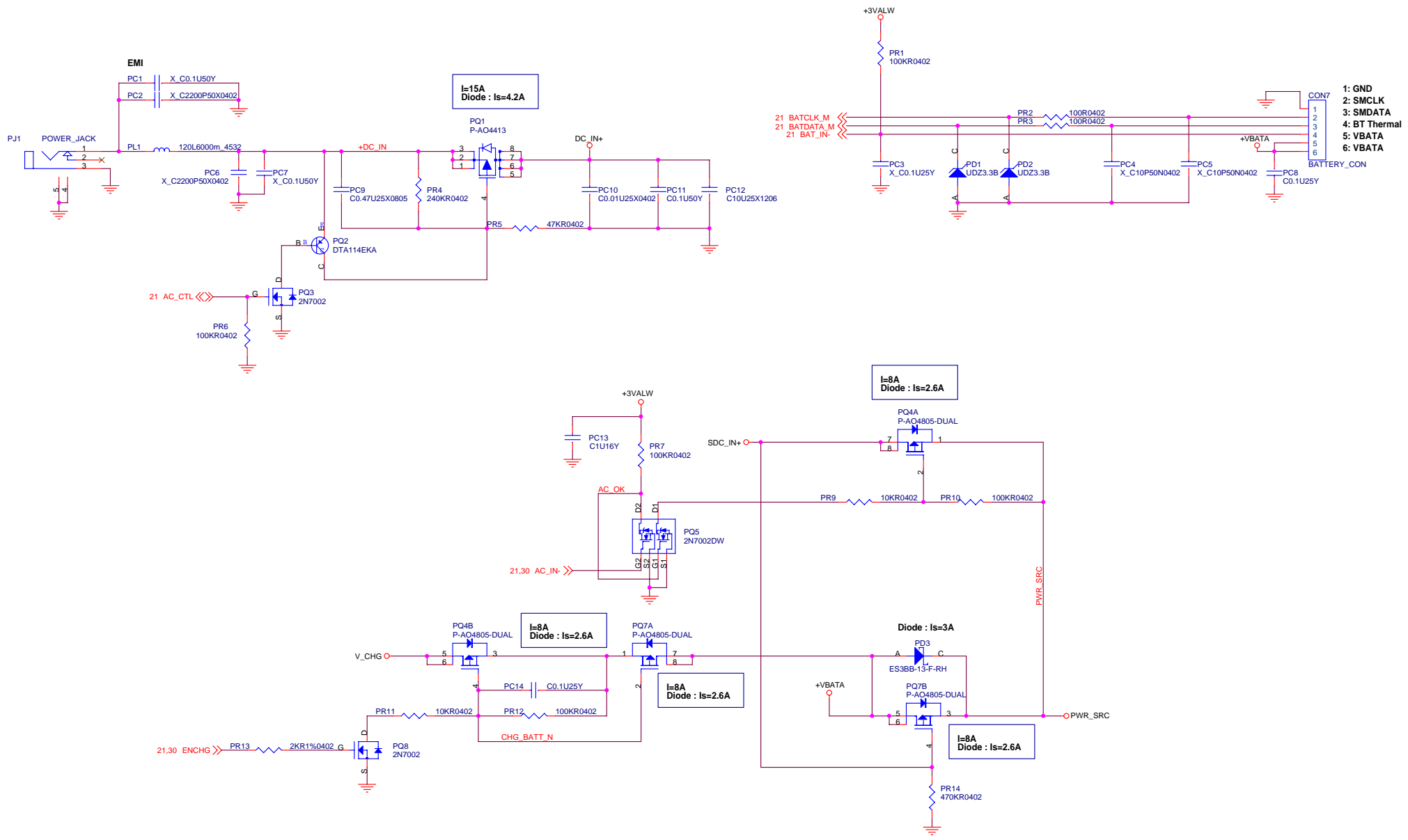

MSI CORPORATION		
Title Battery Select		
Size	Document Number	Rev
Custom	MS-1331	0A
Date:	Wednesday, August 22, 2007	Sheet 29 of 40

Adapter= 65 W
Adapter input voltage set 17.4 Voltage

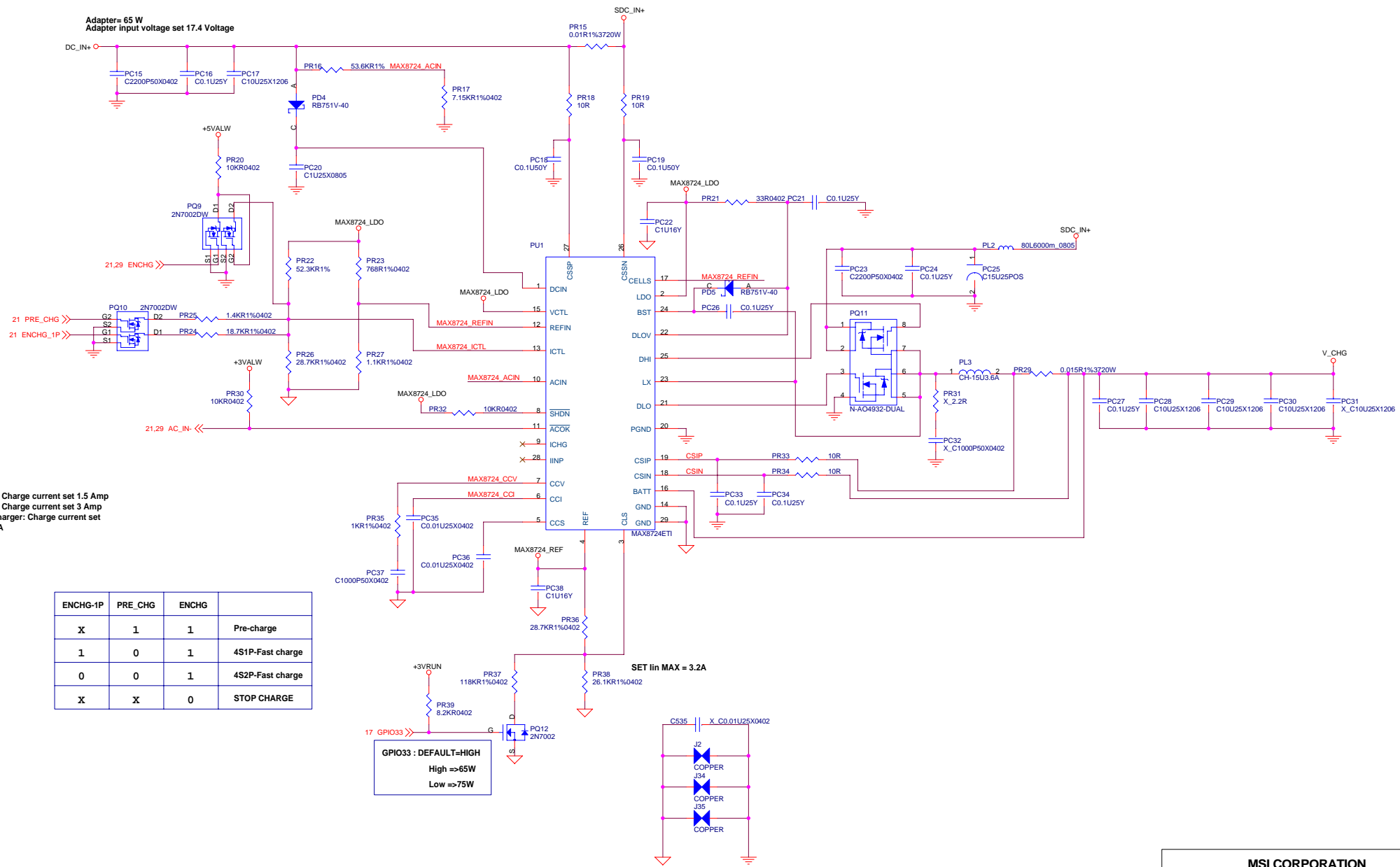

4S1P: Charge current set 1.5 Amp
4S2P: Charge current set 3 Amp
Pre-charger: Charge current set 200mA

ENCHG-1P	PRE_CHG	ENCHG	
X	1	1	Pre-charge
1	0	1	4S1P-Fast charge
0	0	1	4S2P-Fast charge
X	X	0	STOP CHARGE

GPIO33 : DEFAULT=HIGH
High =>65W
Low =>75W

SET Iin MAX = 3.2A

MSI CORPORATION		
Title	Battery Charger	
Size	Document Number	Rev
Custom	MS-1331	0A
Date: Wednesday, August 22, 2007	Sheet	30 of 40

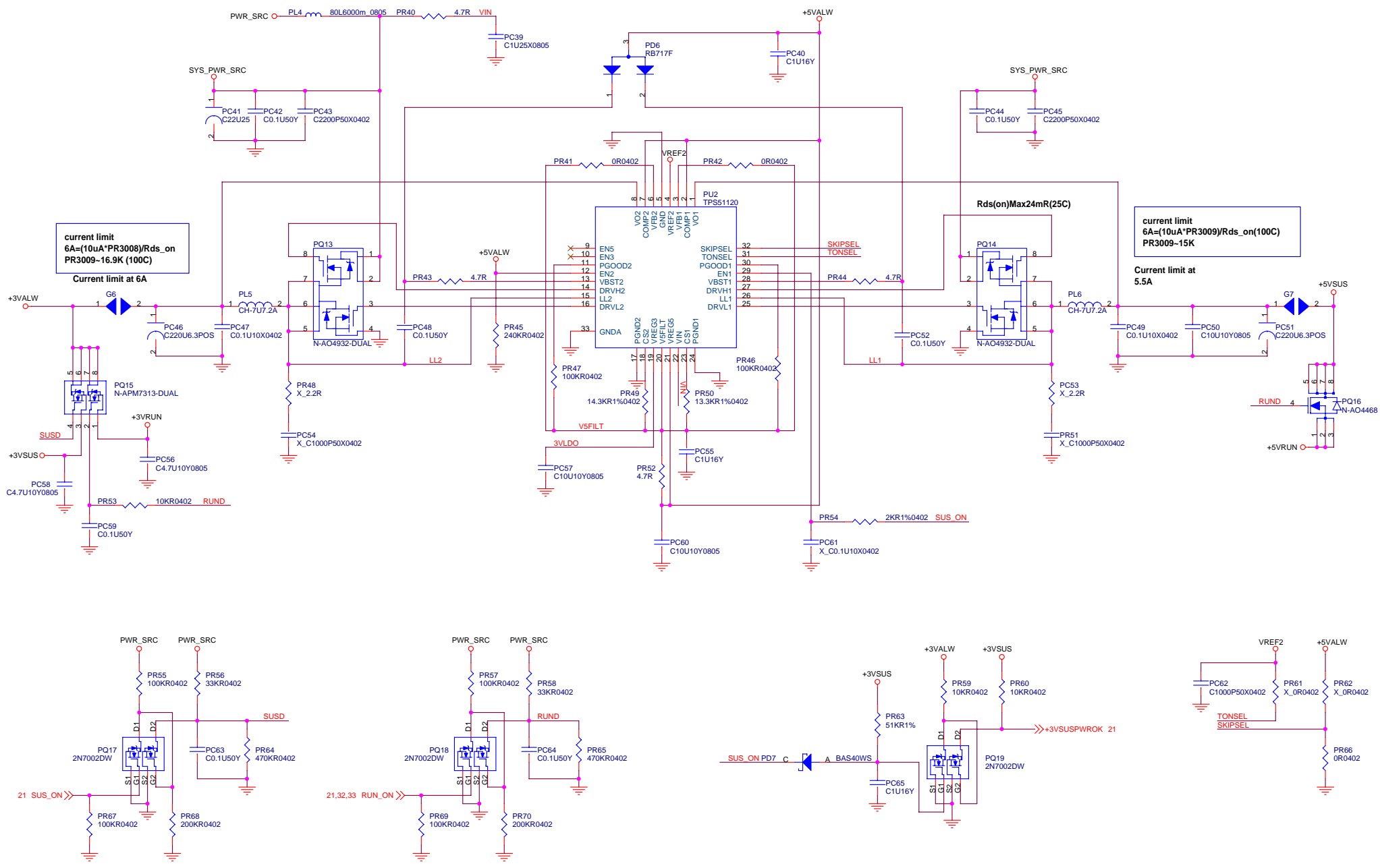

current limit
 $6A = (10\mu A \cdot PR3008) / R_{ds_on}$
 PR3009-16.9K (100C)

current limit
 $6A = (10\mu A \cdot PR3009) / R_{ds_on}(100C)$
 PR3009-15K

Current limit at 5.5A

MSI CORPORATION		
Title		
SYSTEM POWER 3/5V		
Size	Document Number	Rev
Custom	MS-1331	0A
Date:	Wednesday, August 22, 2007	Sheet 31 of 40

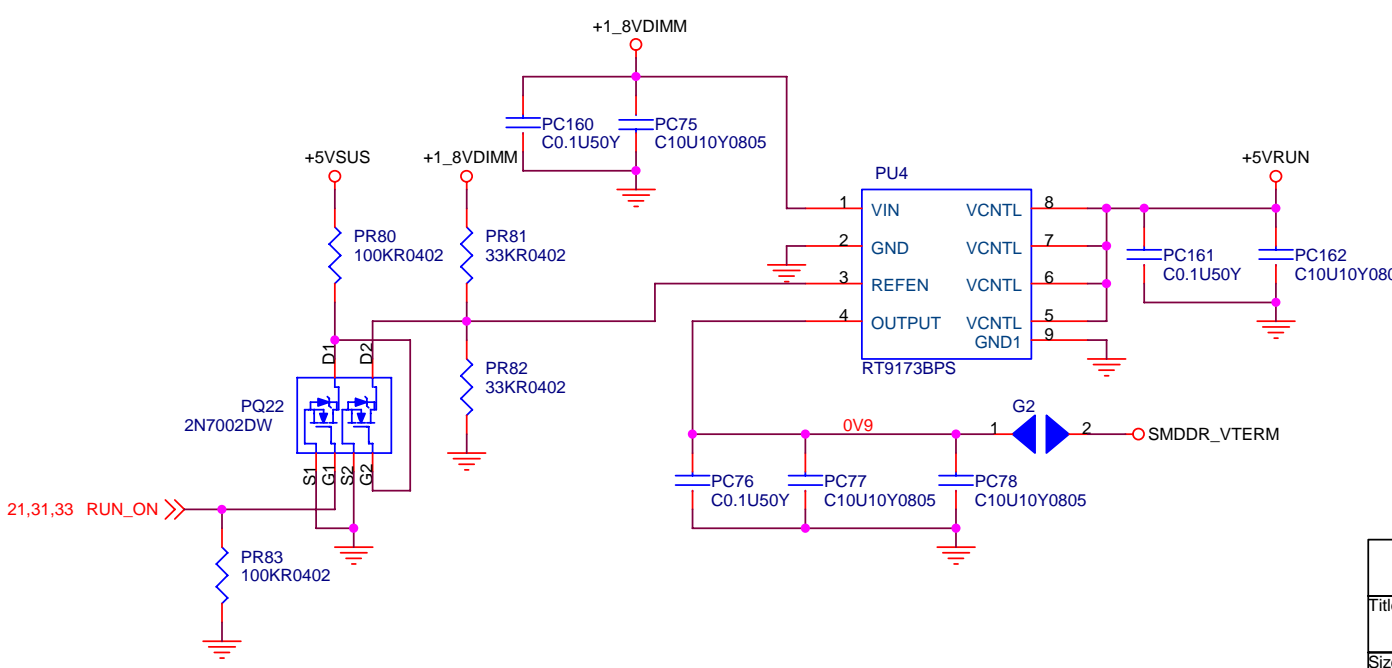
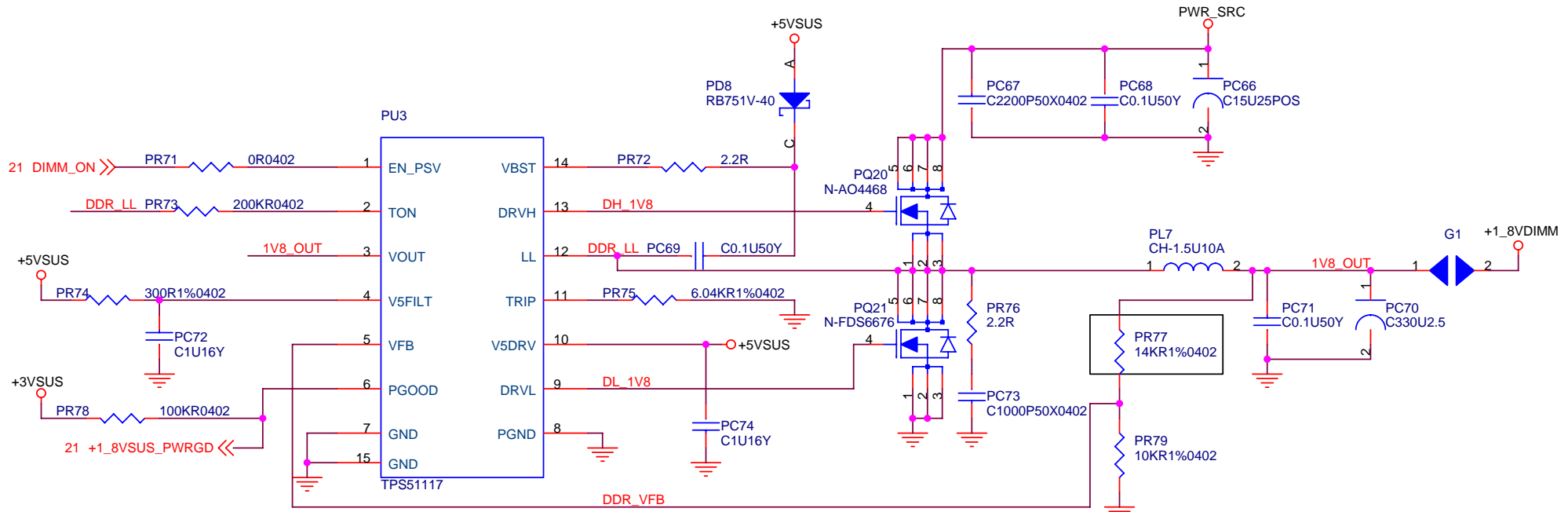

MSI CORPORATION		
DDR2 RAM POWER		
Size A4	Document Number MS-1331	Rev 0A
Date: Thursday, September 06, 2007	Sheet 32	of 40

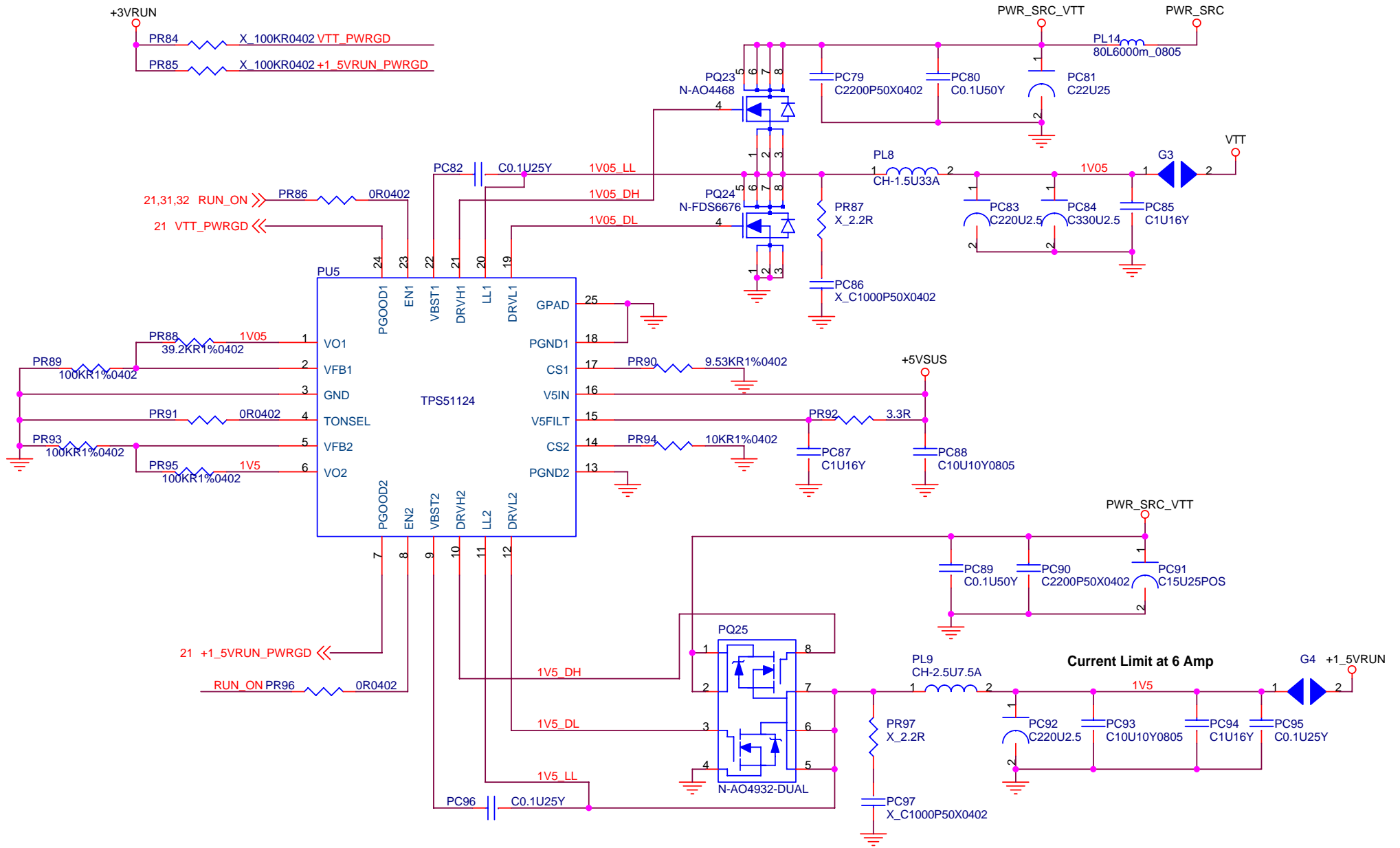

MSI CORPORATION		
+1_5VRUN , VTT POWER		
Size A4	Document Number MS-1331	Rev 0A
Date: Wednesday, August 22, 2007	Sheet 33	of 40

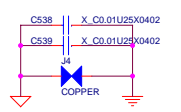

FDE single high should be < 3.3V

locset'Roc=Iocp'Rdroop
 R191=Roc=15A*8m Ohms/10uA - 12.1K
 Where :
 Rdroop is Intel spec : -8m Ohms
 Iocp is desire over current
 locset is recommendation 10uA from Rbias

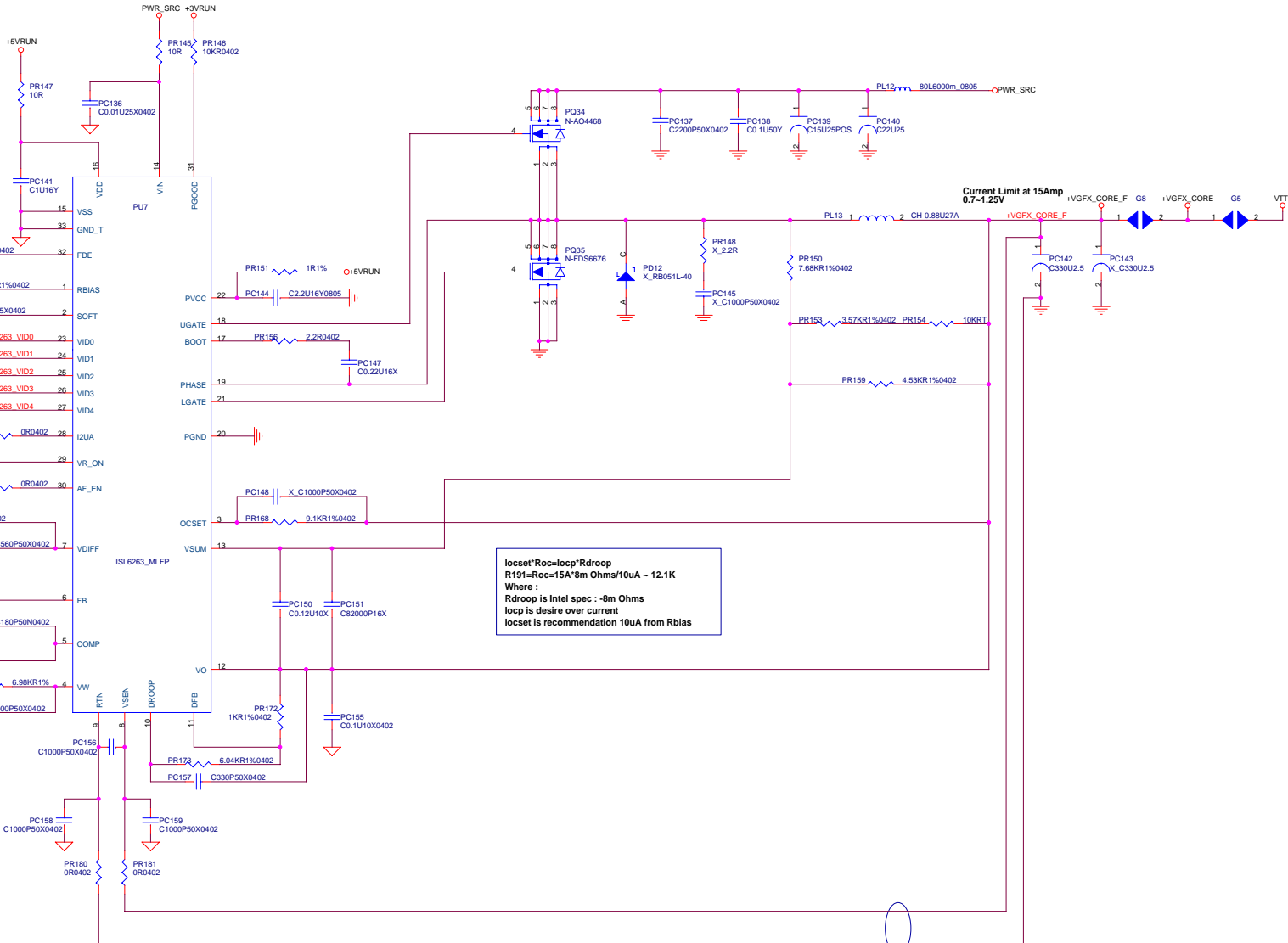
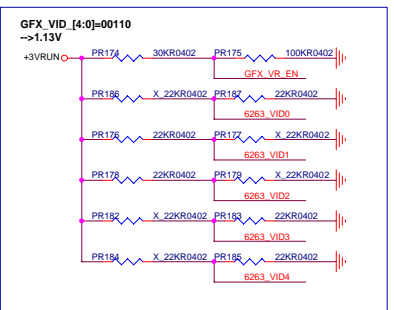

Parallel

MSI CORPORATION		
File	Graphics Core	
Size	Document Number	Rev
C	MS-1331	0A
Date	Wednesday, August 22, 2007	Sheet 35 of 40

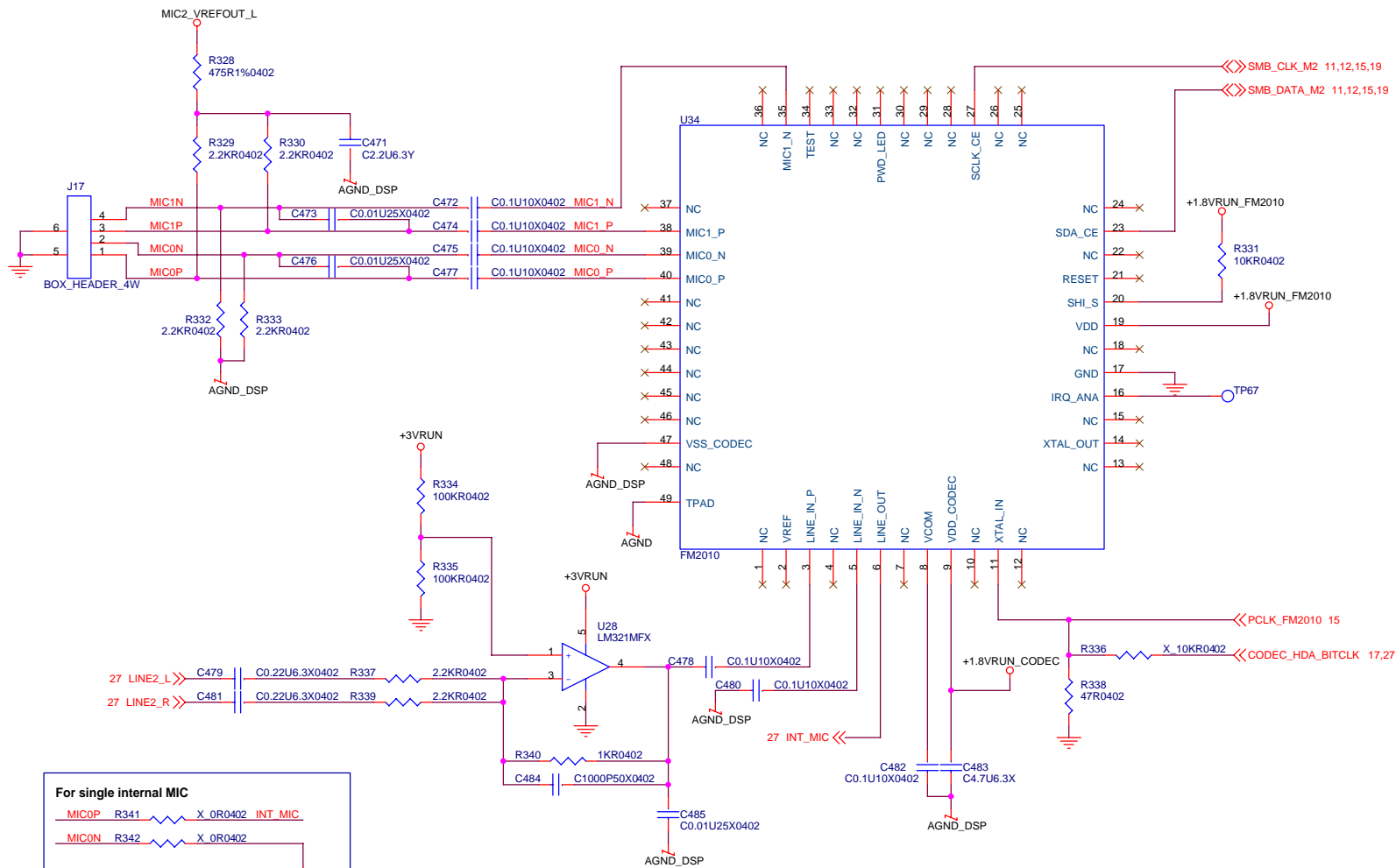

For single internal MIC

MIC0P R341 X 0R0402 INT_MIC
 MIC0N R342 X 0R0402

AGND_DSP

$V_{out} = 1.215(R_u + R_d) / R_d$
 $V_{out} = 1.8V$

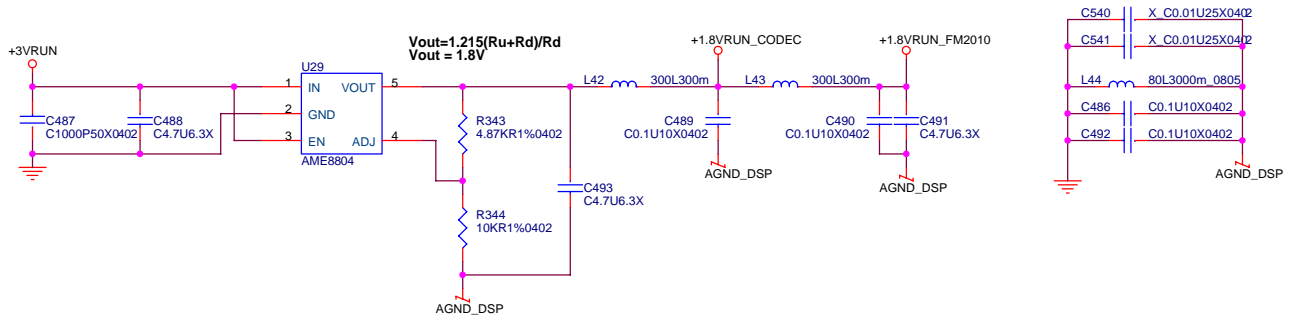

MSI CORPORATION		
Title		
Array Mic FM2010		
Size	Document Number	Rev
Custom	MS-1331	0A
Date:	Wednesday, August 22, 2007	Sheet 36 of 40

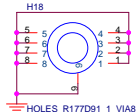
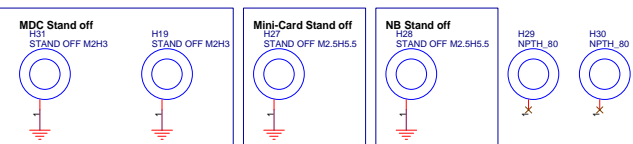
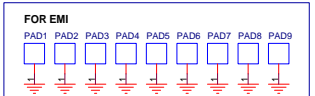
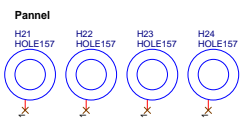
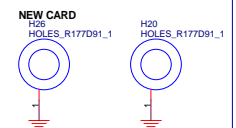
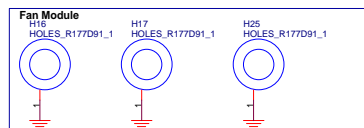
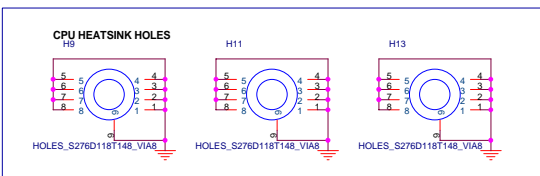
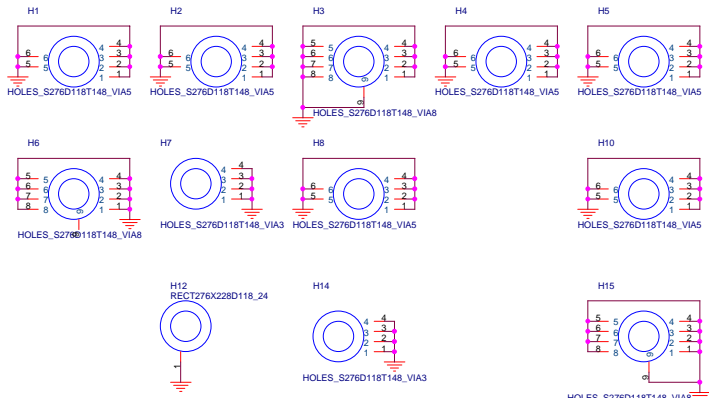
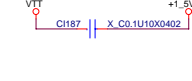
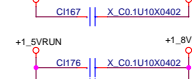
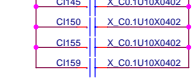
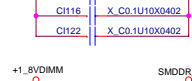
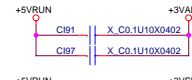
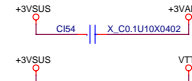
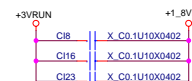
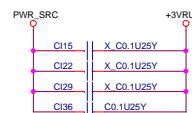
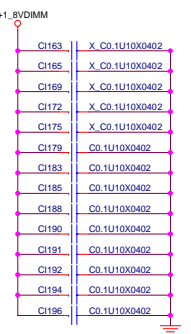
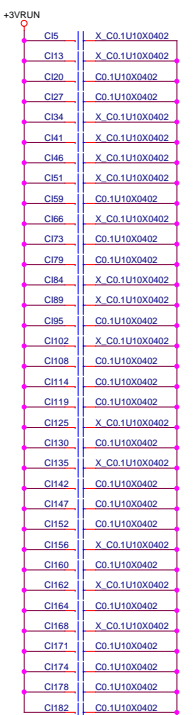
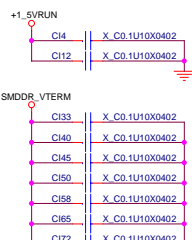
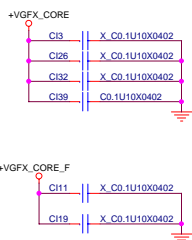
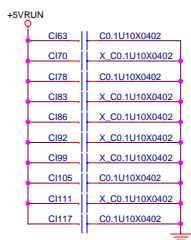

MSI CORPORATION		
File	Screw & EMI	
Size	Document Number	Rev
C	MS-1331	0A
Date	Wednesday, August 22, 2007	Sheet 37 of 40

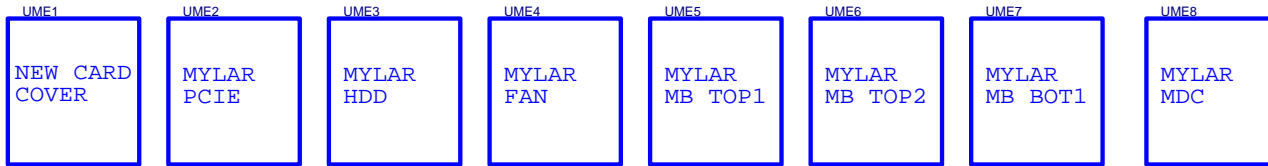

NEW CARD SHIELDING E2M-2210111-SH4
 MYLAR PCIE E2Y-2210211-G40
 MYLAR HDD E2Y-2210311-G40
 MYLAR FAN E2Y-2210411-G40
 MYLAR MB TOP1 E2P-2211611-G40
 MYLAR MB TOP2 E2P-2211711-G40
 MYLAR MB BOT1 E2P-2211511-G40
 MYLAR MDC E2P-2213211-G40

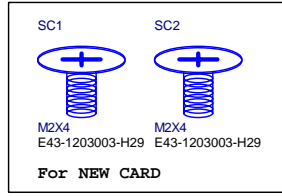
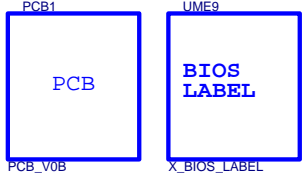

P30-133110B-D05, 昆穎
 P30-133110B-Y34, 元茂

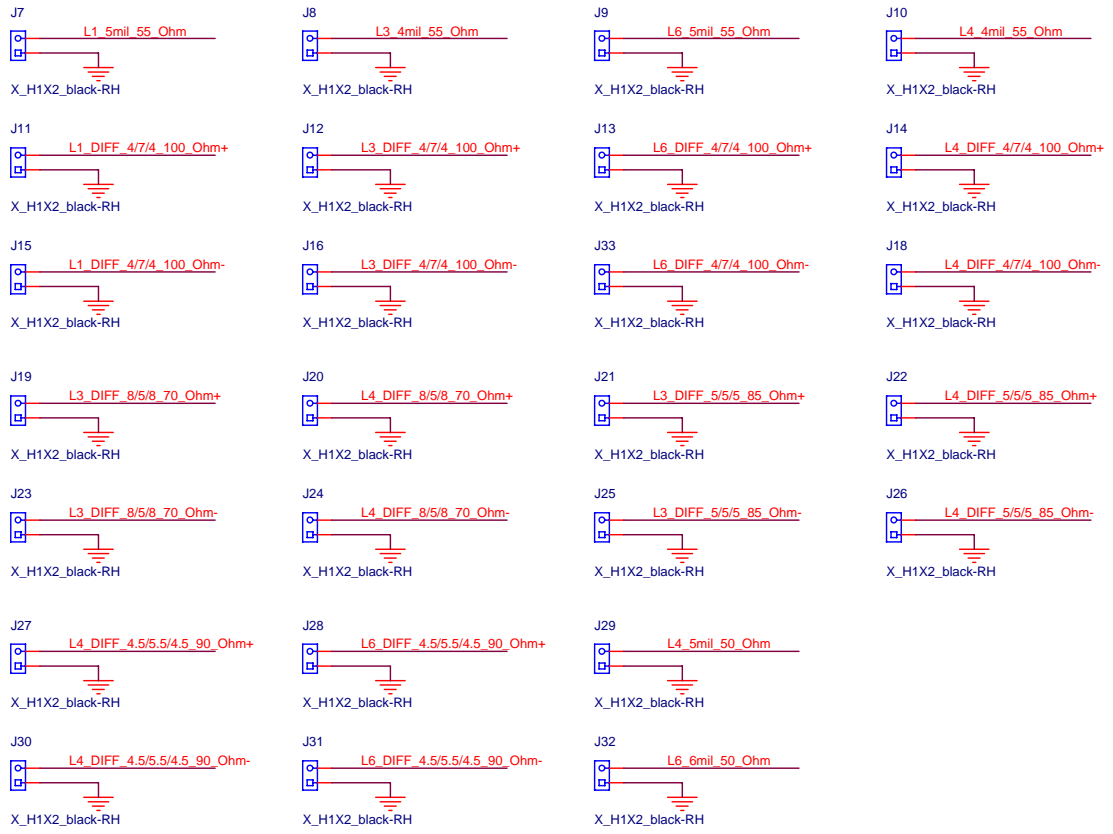
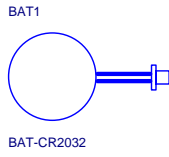

MSI CORPORATION		
Title		
Non-Footprint for BOM		
Size	Document Number	Rev
B	MS-1331	0A
Date:	Wednesday, August 22, 2007	Sheet 38 of 40

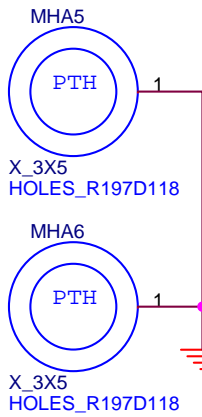

DC Forward Current 30mA (80mA Peak)
Forward Voltage 2.0V (2.4V Max)

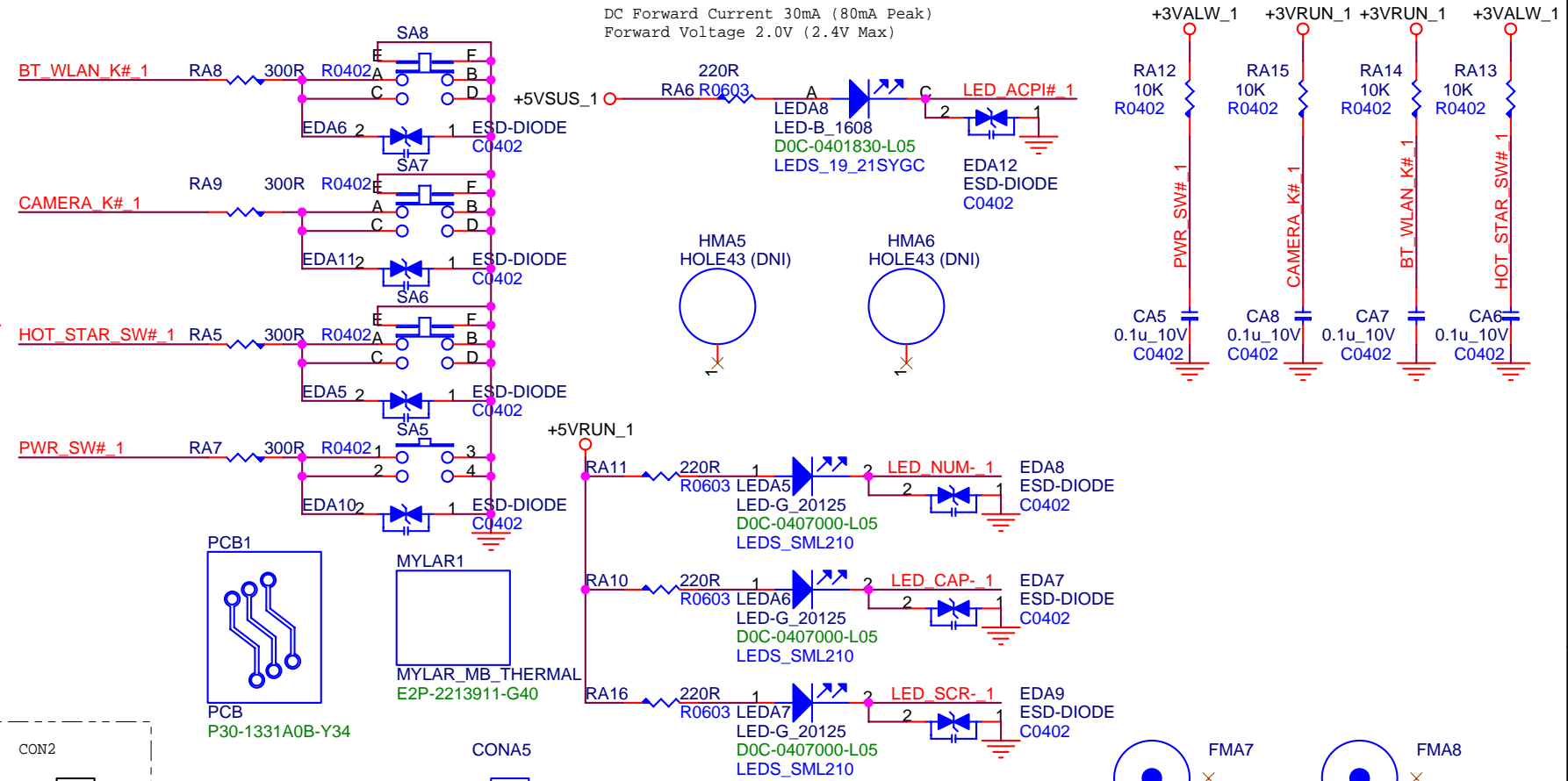

MS12221

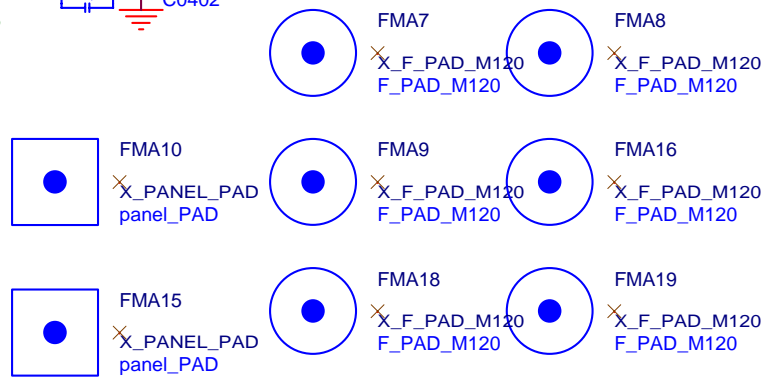
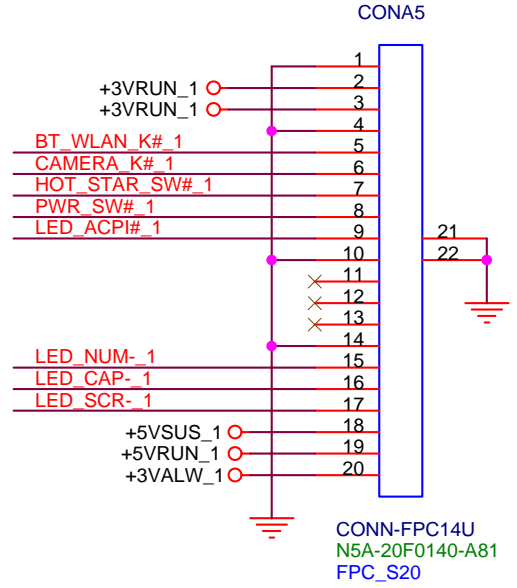
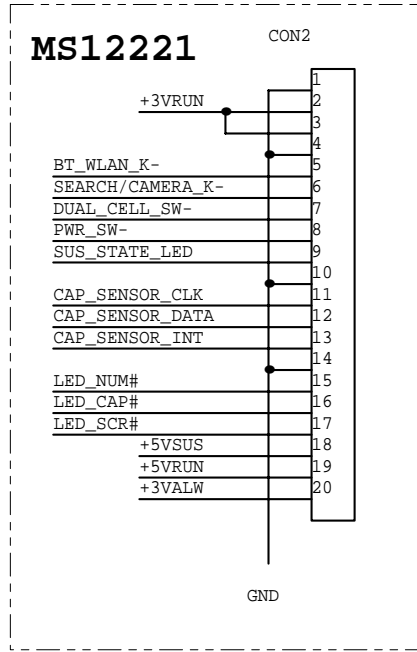

MSI MICRO-STAR INT'L CO.,LTD.

Title
SWITCH BOARD

Size A	Document Number MS-1222	Rev 1.0
-----------	-----------------------------------	------------

Date: Wednesday, August 22, 2007 Sheet 40 of 40